

Egimotors

For Maintenance and Safety

OWNER'S MANUAL

QUADRICYCLE Scrambler XP 1000 E
QUADRICYCLE Scrambler XP 1000 SE

WARNING

Read this manual carefully. It contains important safety information. This is an adult Quadricycle only.
Operation is prohibited for those under 18 years of age.

This Owner Manual refers to EGIMOTORS QUADRICYCLES
(To be filled in by your Dealer)

This Owner's Manual should remain inside you Quadricycle
A digital/printable copy is available on www.egimotors.com

Year _____

Model Type _____

Code number (spare parts use only) _____

VIN Number _____

Engine Serial Number _____

Key Number _____

Registration Plate Number _____

Welcome !

Thank you for purchasing an Egimotors Quadricycle, and welcome to our world-wide family of enthusiasts.

We have done This manual to inform you on how to use and maintain the best condition of operation for your Quadricycle.

If after reading this manual, you still have some questions please do not hesitate to contact your dealer that will be available to help you.

Be sure to visit us online at www.Egimotors.it for the latest news and for product and Safety information.

We believe we sets a standard of excellence for all utility and Quadricycle manufactured in the world today.

Many years of experience have gone into the engineering, design, and development of your Quadricycle, making it the finest machine we've ever produced.

For safe and enjoyable operation of your Quadricycle, be sure to follow the instructions and recommendations in this owner's manual.

Your manual contains instructions for the maintenance of the Quadricycle and information about repairs.

Service Manual are available from Dealers, only them can perform major repair and install accessory.

Your dealer knows your Quadricycle better than anyone and is interested in your total satisfaction, he can perform your service needs during and after the warranty period.

For the most up-to-date owner's manual visit:

<http://egimotors.it/libretto-uso-manutenzione/>

Read and understand this Owner's Manual is extremely important for your safety and for all the operators, so please take your time to read all the pages and be sure that is someone else will use the Quadricycle before will take this manual and read and understand all, this will give you the best knowledge and skills on how to ride in security.

Copyright 2023 Egimotors.

All the information contained within this publication is based on the latest product information at the time of publication.

Due to constant improvement in the design and quality of product components, some minor discrepancies may result between the actual unit and the information presented in this publication.

Descriptions and or procedure in this publication are intended for reference use only. No Liability can be accepted for omission or inaccuracies. Any reprinting or reuse of the depictions and or procedures contained within this publication are intended for reference use only. The original instruction is in English.

Other languages are provided as translation of the original Instruction see the Egimotors website for more details and procedure.

The following signal words and symbols appear throughout this manual and on your Quadricycle. Your safety is involved when these words and symbols are used. Become familiar with their meanings before reading the manual.

 **DANGER**

DANGER indicates a hazardous situation which, if not avoided, WILL result in death or serious injury.

 **WARNING**

WARNING indicates a hazardous situation which, if not avoided, COULD result in death or serious injury.

 **CAUTION**

CAUTION indicates a hazardous situation which, if not avoided, COULD result in minor to moderate injury.

NOTICE

NOTICE provides key information by clarifying instructions.

IMPORTANT

IMPORTANT provides key reminders during disassembly, assembly, and inspection of components.

The Prohibition Safety Sign indicates an action NOT to take in order to avoid a hazard.



The Mandatory Action Sign indicates an action that NEEDS to be taken to avoid a hazard.



TABLE OF CONTENTS

Introduction
Safety
Features and Controls
Operation
Winch Guide
Emission Control Systems
Maintenance
Diagnostic Display Codes
Specifications
EGIMOTORS Products
Troubleshooting
Warranty
Maintenance Log
Certificate of Delivery

INTRODUCTION

IMPORTANT WARNING ABOUT THIS MANUAL

 **WARNING**

Failure to heed the warnings and safety precautions contained in this manual can result in severe injury or death. An EGIMOTORS QUADRICYCLE is not a toy and can be hazardous to operate. This Quadricycle handles differently than other Quadricycles, such as motorcycles and cars. A collision or rollover can occur quickly, even during routine maneuvers like turning, or driving on hills or over obstacles, if you fail to take proper precautions.

- Read this owner's manual. Understand all safety warnings, precautions and operating procedures before operating a EGIMOTORS QUADRICYCLE.
- Never operate a QUADRICYCLE without proper instruction. Take a certified QUADRICYCLE safety training course.
- This Quadricycle is an ADULT QUADRICYCLE ONLY. Operation is prohibited for anyone under 16 years of age.
- Never permit a guest to operate the QUADRICYCLE unless the guest has read this manual and all product labels and has completed a certified safety training course.

TOOLS FOR SAFE RIDING

To safely operate this Quadricycle, it is important to become familiar with its features, controls, and characteristics. Review the Safety Briefings for this Quadricycle that apply to you:

- Operators
- Riders
- Owners
- Trailering the Quadricycle
- Maintaining the Quadricycle

Additionally, read the product safety labels on the Quadricycle and follow all rules and regulations concerning the operation of this Quadricycle in your area.

EGIMOTORS recommends anyone who will be operating this Quadricycle to take a training course.

QUADRICYCLE IDENTIFICATION NUMBERS

The Quadricycle identification number (VIN) can be found stamped on the right rear frame tube ①.

Record your Quadricycle's identification numbers and key number in the spaces provided. Remove the spare key and store it in a safe place. An ignition key can be duplicated only by ordering a EGIMOTORS key blank (using your key number) and mating it with one of your existing keys. The ignition switch must be replaced if all keys are lost.

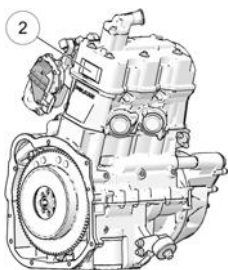
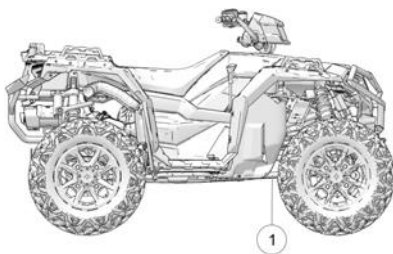

Quadricycle Model Number	
Frame VIN ①	
Engine Serial Number ②	
Key Number ③	

RADIO COMPLIANCE STATEMENTS

EUROPEAN UNION (EU) RADIO COMPLIANCE

This Quadricycle may contain the following radio equipment or components that contain radio equipment:

COMPONENT	B1 Gauge Bluetooth® LE
COMPONENT ID	CYBLE-222014-01
MANUFACTURER	Cypress Semiconductor
TRANSMITTING FREQUENCY*	2402 - 2480 MHz
MAX RF TRANSMITTING PWR	0.78 mW
* Other transmitting radio frequencies may exist outside of EU markets.	

Hereby, Egimotors declares that the above radio equipment is in compliance with Directive 2014/53/EU.

SAFETY

SAFETY WARNING

As the operator of the Quadricycle, you are responsible for your personal safety, the safety of others (including your passenger), and the protection of our environment. Read and understand your owner's manual, which includes valuable information about all aspects of your Quadricycle, including safe operating procedures.

Ride responsibly. Know all laws and regulations concerning the operation of this Quadricycle in your area.

Failure to follow the warnings in this manual can result in serious injury or death. This EGIMOTORS Quadricycle is not a toy and can be hazardous to operate. A collision or rollover can occur quickly, even during routine maneuvers, if you fail to take proper precautions.

Read and understand your owner's manual and all warnings before operating this EGIMOTORS Quadricycle.

SAFETY TRAINING

Safety training is a top priority for EGIMOTORS. EGIMOTORS strongly encourages you and any family members who will be riding this Quadricycle to take a training course.

Your EGIMOTORS Quadricycle is considered an off-road Quadricycle. Familiarize yourself with all laws and regulations concerning the operation of this Quadricycle in your area.

We strongly advise you to strictly follow the recommended maintenance program outlined in your owner's manual. This preventive maintenance program is designed to ensure that all critical components on your Quadricycle are thoroughly inspected at specific intervals.

SAFETY

SAFE RIDING GEAR

Always wear helmet, eye protection, gloves, long-sleeve shirt, long pants, and over-the-ankle boots at all times. Protective gear reduces the chance of injury.

- ① Helmet
- ② Eye Protection
- ③ Long Sleeves
- ④ Gloves
- ⑤ Long Pants
- ⑥ Over-the-Ankle Boots



HELMET

Wearing a helmet can prevent a severe head injury. Whenever riding this EGIMOTORS Quadricycle, always wear a helmet that meets or exceeds established safety standards. Clasp the buckle and pull each strap tight to ensure the helmet is properly secured to the head.

Approved helmets in Europe bear the ECE 22.05 label. The ECE mark consists of a circle surrounding the letter E, followed by the distinguishing number of the country which has granted approval. The approval number and serial number will also be displayed on the label.



EYE PROTECTION

Do not depend on eyeglasses or sunglasses for eye protection. Whenever riding this EGIMOTORS Quadricycle, always wear shatterproof goggles or use a shatterproof helmet face shield. EGIMOTORS recommends wearing approved Personal Protective Equipment (PPE) bearing markings such as VESC 8, V-8, Z87.1, or CE. Make sure protective eye wear is kept clean.

GLOVES

Wear gloves for comfort and for protection from sun, cold weather and other elements.

BOOTS

Wear sturdy over-the-ankle boots for support and protection. Never ride a EGIMOTORS Quadricycle with bare feet or sandals.

CLOTHING

Wear long sleeves and long pants to protect arms and legs.

SAFETY WARNINGS

WARNING

Failure to operate this Quadricycle properly can result in a collision, loss of control, accident or rollover, which may result in serious injury or death. Heed all safety warnings outlined in this section of the owner's manual. See the operation section of this owner's manual for proper operating procedures.

OPERATING WITHOUT INSTRUCTION

Operating this QUADRICYCLE without proper instruction increases the risk of an accident. The operator must understand how to operate the QUADRICYCLE properly in different situations and on different types of terrain.

Beginning and inexperienced operators should complete the recommended safety training before operating this Quadricycle.

Never permit a guest to operate the QUADRICYCLE unless the guest has read this manual and all product labels and has completed a certified safety training course.



SAFETY

AGE RESTRICTIONS

This Quadricycle is an **ADULT QUADRICYCLE ONLY**. Operation is prohibited for anyone under 18 years of age.

Never allow anyone under 12 years of age to ride as a passenger on a 2-up QUADRICYCLE.

Even though a child may be within the recommended age group for operating some QUADRICYCLES, they may not have the skills, abilities, or judgment needed to operate or ride on this QUADRICYCLE safely and could be susceptible to accident or injury.



USING ALCOHOL OR DRUGS

Never consume alcohol or drugs before or while operating this Quadricycle.

Operating this Quadricycle after consuming alcohol or drugs could adversely affect operator judgment, reaction time, balance and perception.



FAILURE TO INSPECT BEFORE OPERATING

WARNING

Failure to inspect and verify that the Quadricycle is in safe operating condition before operating increases the risk of an accident.

Always perform the pre-ride inspection before each use of your Quadricycle to make sure it's in safe operating condition.

Always follow the inspection and maintenance procedures and schedules described in this owner's manual.

HANDLING GASOLINE

Gasoline is highly flammable and explosive under certain conditions.

- Always exercise extreme caution whenever handling gasoline.
- Always refuel with the engine stopped, and outdoors or in a well-ventilated area.
- Never carry fuel or other flammable liquids on this Quadricycle. Failure to follow this instruction could lead to serious burn injuries or death.
- Do not smoke or allow open flames or sparks in or near the area where refueling is performed or where gasoline is stored.
- Do not overfill the tank. Do not fill the tank neck.
- If gasoline spills on your skin or clothing, immediately wash it off with soap and water and change clothing.

EXPOSURE TO EXHAUST



Engine exhaust fumes are poisonous and can cause loss of consciousness or death in a short time. Never start the engine or let it run in an enclosed area. Operate this Quadricycle only outdoors or in well-ventilated areas.

PROTECTIVE APPAREL

Riding in this Quadricycle without wearing an approved helmet and protective eye wear increases the risk of a serious injuries in the event of an accident.

Always wear a helmet, eye protection, gloves, long-sleeve shirt, long pants and over-the-ankle boots.



SAFETY

OPERATING ON PUBLIC ROADS

If your Quadricycle is registered with a license plate as for public use road, anyway, operating this Quadricycle on mayor public streets could result in a collision with another vehicle.

Never operate this Quadricycle on highway see your locals law concerning the category of your Quadricycle and where you can use it.

Quadricycles are allowed only on secondary road with a limited speed, respect all the rules.

OPERATING AT EXCESSIVE SPEEDS

Operating this Quadricycle at excessive speeds increases the operator's risk of losing control. Always operate at a speed that's appropriate for the terrain, the visibility and operating conditions and your skills and experience.



PHYSICAL CONTROL OF THE QUADRICYCLE

Removing even one hand or foot can reduce ability to control the Quadricycle or could cause loss of balance and ejection from the QUADRICYCLE.

If a person's feet are not firmly planted on the footrests, they could come into contact with the wheels or other moving parts and lead to accident or injury.

Always keep both hands on the handlebars and both feet on the footrests of the QUADRICYCLE during operation.

TURNING IMPROPERLY



Turning improperly could cause loss of traction, loss of control, accident or rollover. Always follow proper procedures for turning as described in this owner's manual.

Avoid sharp turns. Never turn while applying heavy throttle. Never make abrupt steering maneuvers. Practice turning at slow speeds before attempting to turn at faster speeds.

SAFETY

JUMPS AND STUNTS

Exhibition driving increases the risk of an accident or rollover. **DO NOT** do power slides, "donuts", jumps or other driving stunts. Avoid exhibition driving.



IMPROPER HILL CLIMBING

Improper hill climbing could cause loss of control or rollover. Use extreme caution when operating on hills. Always follow proper procedures for hill climbing as described in this owner's manual. See the New Operator Driving Procedures section for details.

DESCENDING HILLS IMPROPERLY

Improperly descending a hill could cause loss of control or rollover. Always follow proper procedures for traveling down hills as described in this owner's manual. See the New Operator Driving Procedures section for details.

CROSSING HILLSIDES

Driving on a sidehill is not recommended. Improper procedure could cause loss of control or rollover. Avoid crossing the side of any hill unless absolutely necessary.

If crossing a hillside is unavoidable, always follow proper procedures as described in this owner's manual. See the New Operator Driving Procedures section for details.

STALLING WHILE CLIMBING A HILL

Stalling, rolling backwards or improperly dismounting while climbing a hill could cause a rollover.

- Always maintain a steady speed when climbing a hill.
- Always engage ADC mode (if equipped) before ascending or descending a hill. If ADC mode is not equipped, apply AWD mode before ascending or descending a hill.



If all forward speed is lost:

- Lean forward to keep body weight uphill. A passenger should also lean uphill.
- Apply the brakes.
- Lock the parking brake when fully stopped.
- Dismount on the uphill side of the Quadricycle, or on the left if the Quadricycle is pointing straight uphill. Have a passenger dismount first, then the operator may dismount.
- Turn the QUADRICYCLE around and remount, following the procedure described in the owner's manual.

If the QUADRICYCLE begins rolling downhill:

- Keep operator and passenger body weight uphill.
- Never apply engine power.
- Apply the brake lever gradually.
- When fully stopped, apply the auxiliary brake as well, and then lock the parking brake.
- Dismount on the uphill side of the Quadricycle, or on the left if the Quadricycle is pointing straight uphill. Have a passenger dismount first, then the operator may dismount.
- Turn the QUADRICYCLE around and remount, following the procedure described in the owner's manual.

SAFETY

OPERATING ON STEEP HILLS

Operating on excessively steep hills could cause an overturn.

Never operate on hills too steep for the QUADRICYCLE or for your abilities.

Never operate this QUADRICYCLE on hills steeper than 15 degrees.



OPERATING ON SLIPPERY TERRAIN

Failure to use extra caution when operating on excessively rough, slippery or loose terrain could cause loss of traction, loss of control, accident or overturn.

Do not operate on excessively rough, slippery or loose terrain until you've learned and practiced the skills necessary to control the Quadricycle on such terrain.

Always use extra caution on rough, slippery or loose terrain.



OPERATING IN UNFAMILIAR TERRAIN

Failure to use extra caution when operating on unfamiliar terrain could result in an accident or rollover.

Unfamiliar terrain may contain hidden rocks, bumps, or holes that could cause loss of control or rollover.

Travel slowly and use extra caution when operating on unfamiliar terrain. Always be alert to changing terrain conditions.

IMPROPER TIRE MAINTENANCE

Operating this Quadricycle with improper tires or with improper or uneven tire pressure could cause loss of control or accident.

Always use the size and type of tires specified for your Quadricycle.

Always maintain proper tire pressure as described in the owner's manual and on safety labels.



OPERATING IMPROPERLY IN REVERSE

Improperly operating in reverse could result in a collision with an obstacle or person. Always follow proper operating procedures as outlined in this manual. See the New Operator Driving Procedures section for details.

Before shifting into reverse gear, always check for obstacles or people behind the Quadricycle. When it's safe to proceed, back slowly.

OPERATING OVER OBSTACLES

Improperly operating over obstacles could cause loss of control or rollover.

Before operating in a new area, check for obstacles. Avoid operating over large obstacles such as large rocks and fallen trees. Always follow the proper procedures outlined in this manual when operating over obstacles. See the New Operator Driving Procedures section for details.



SAFETY

SKIDDING OR SLIDING

Failure to use extra caution when operating on excessively rough, slippery or loose terrain could cause loss of traction, loss of control, accident or rollover. Do not operate on excessively slippery surfaces. Always slow down and use additional caution when operating on slippery surfaces.

Skidding or sliding due to loss of traction can cause loss of control or rollover (if tires regain traction unexpectedly). Always follow proper procedures for operating on slippery surfaces as described in this owner's manual. See the New Operator Driving Procedures section for details.



OPERATING A DAMAGED QUADRICYCLE

CAUTION

Operating a damaged Quadricycle can result in an accident. After any rollover or other accident, have a qualified service dealer inspect the entire machine for possible damage, including (but not limited to) brakes, throttle, and steering systems.

OPERATING THROUGH WATER

Operating through deep or fast-flowing water can cause loss of traction, loss of control, rollover or accident. Never operate in fast-flowing water or in water that exceeds the floor level of the Quadricycle.

Always follow proper procedures for operating in water as described in this owner's manual.

Wet brakes may have reduced stopping ability. After leaving water, test the brakes. Apply them lightly several times while driving slowly. The friction will help dry out the pads.

IMPROPER CARGO LOADING

Overloading the Quadricycle or carrying cargo improperly may cause changes in stability and handling, which could cause loss of control or an accident.

- Always follow the instructions in this owner's manual for carrying cargo.
- Never exceed the stated load capacity for this Quadricycle.
- Cargo should be properly distributed and securely attached.
- Reduce speed when carrying cargo or pulling a trailer. Allow a greater distance for braking.

OPERATING ON FROZEN BODIES OF WATER

Severe injury or death can result if the Quadricycle and/or the operator fall through the ice. Never operate the Quadricycle on a frozen body of water unless you have first verified that the ice is sufficiently thick to support the weight and moving force of the Quadricycle, you and your cargo, together with any other Quadricycles in your party.

Always check with local authorities and residents to confirm ice conditions and thickness over your entire route. Quadricycle operators assume all risk associated with ice conditions on frozen bodies of water.

POOR VISIBILITY



Operating this Quadricycle in darkness or inclement weather could result in a collision or accident, especially if operating on a road or street. This Quadricycle is not equipped with highway-approved lights. Operate this Quadricycle off-road only. Use caution and drive at reduced speeds in conditions of reduced visibility such as fog, rain and darkness. Clean headlights frequently and replace burned out headlamps promptly.

PHYSICAL SKILLS

Safe operation of this rider-active Quadricycle requires good judgement and physical skills. Persons with cognitive or physical disabilities who operate this Quadricycle have an increased risk of overturn and loss of control.

SAFETY

HOT EXHAUST SYSTEMS



Exhaust system components are very hot during and after use of the Quadricycle. Hot components can cause burns and fire. Do not touch hot exhaust system components. Always keep combustible materials away from the exhaust system.

Use caution when traveling through tall grass, especially dry grass and when traveling through muddy conditions. Always inspect the underside of the Quadricycle and areas near the exhaust system after driving through tall grass, weeds, brush, other tall ground cover, and muddy conditions. Promptly remove any grass, debris or foreign matter clinging to the Quadricycle and pay particular attention to the exhaust system area.

UNAUTHORIZED USE OF THE QUADRICYCLE

Leaving the keys in the ignition can lead to unauthorized use of the Quadricycle by someone under the age of 18, without a driver's license, or without proper training. This could result in an accident or rollover. Always remove the ignition key when the Quadricycle is not in use.

EQUIPMENT MODIFICATIONS

Your EGIMOTORS Quadricycle is designed to provide safe operation when used as directed. Modifications to your Quadricycle may negatively impact Quadricycle stability. Failure of critical machine components may result from operation with any modifications, especially those that increase speed or power. This Quadricycle may become less stable at speeds higher than those for which it is designed. Loss of control may occur at higher speeds.

Do not install any non-EGIMOTORS-approved accessory or modify the Quadricycle for the purpose of increasing speed or power. Any modifications or installation of non-EGIMOTORS-approved accessories could create a substantial safety hazard and increase the risk of bodily injury.

The EGIMOTORS limited warranty on your EGIMOTORS Quadricycle will be terminated if any non-EGIMOTORS approved equipment and/or modifications have been added to the Quadricycle that increase speed or power.

The addition of certain accessories, including (but not limited to) mowers, blades, tires, sprayers, or large racks, may change the handling characteristics of the Quadricycle. Use only EGIMOTORS-approved accessories and familiarize yourself with their function and effect on the Quadricycle.

For more information about QUADRICYCLE safety, see the Safety Training section.

TRAILER HITCH WARNING (IF EQUIPPED)

If using a hitch, ensure the receiver does not exceed a two inch drop or raise.

 **WARNING**

When trailering with your QUADRICYCLE, be aware that the exhaust is located above the hitch ball receiver and the trailer hitch. During operation of the QUADRICYCLE, the exhaust will produce hot exhaust gas that should not be inhaled and that may elevate the surface temperature of surrounding surfaces, including trailer surfaces (e.g., trailer hitch, trailer tongue, trailer walls, . . . etc.). To reduce the risk of inhaling exhaust gases and to avoid risk of burn or injury, shut off your engine and allow time for the exhaust gases to dissipate and for the surfaces surrounding the exhaust to cool, including the trailer surfaces, before connecting or disconnecting a trailer. To reduce the potential for the trailer hitch or trailer tongue from getting too hot, do not use a receiver hitch with a rise of more than two inches.

SAFETY

SAFETY LABELS AND LOCATIONS

Warning labels are placed on the Quadricycle for your protection. Read and follow the instructions on each label carefully. If any of the labels shown in this manual differ from the labels on your Quadricycle, always read and follow the instructions of the labels on the Quadricycle.

If an informational or graphic label becomes illegible or comes off, contact your EGIMOTORS dealer to procure a replacement. Replacement safety labels are provided by EGIMOTORS at no charge. The part number is printed on the label.

SCRAMBLER XP 1000

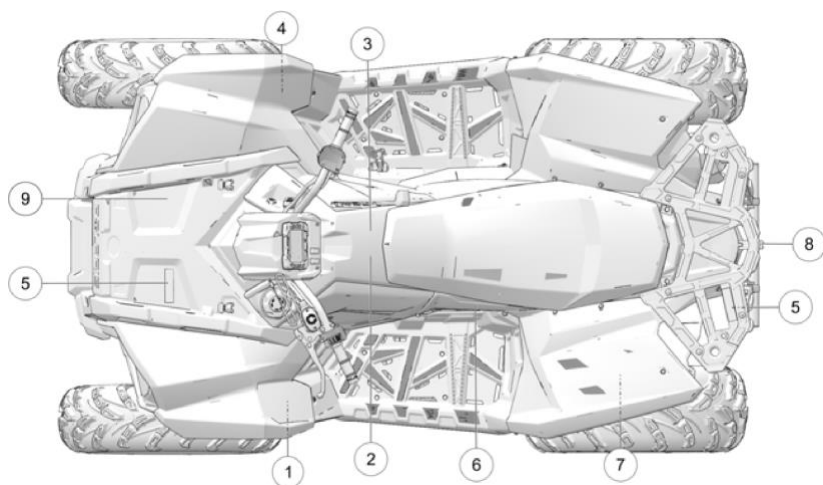

- ① General Alert
- ② Override Alert
- ③ 4x4 Alert
- ④ Discretionary Alert
- ⑤ Rack Alerts

- ⑥ Clutch Cover Alert
- ⑦ Tire Pressure Alert
- ⑧ Hitch Capacity Alert
- ⑨ Radiator Cap Alert

GENERAL ALERT**⚠ WARNING**

Before you operate this Quadricycle, read the owner's manual. Never allow anyone under 18 years of age to operate this Quadricycle. Wear approved helmet, goggles, and protective clothing. Never use alcohol or drugs before or while operating. Never carry more than one passenger on this Quadricycle. This vehicle is approved for on-road use, refer to your local laws.

**VERRIDE ALERT****⚠ WARNING**

Improper use of override button can lead to loss of control resulting in severe injury or death. Do not activate override while throttle is engaged. Always apply throttle gradually while in reverse.

**VERRIDE ALERT/4X4 ALERT**

SAFETY

⚠ WARNING

Improper use of override button can lead to loss of control resulting in severe injury or death. Do not activate override while throttle is engaged. Always apply throttle gradually while in reverse.

⚠ WARNING

Do not push switch to engage 4X4 (AWD) if the rear wheels are spinning. This may cause severe drive shaft and clutch damage.

4X4 (AWD) ALERT

⚠ WARNING

Do not push switch to engage 4X4 (AWD) if the rear wheels are spinning. This may cause severe drive shaft and clutch damage.



DISCRETIONARY ALERT

⚠ WARNING

Read and understand your owner's manual. Never operate this Quadricycle on HILLS steeper than 15°.



SCRAMBLER XP 1000

⚠ WARNING

DO NOT TOW FROM RACK OR BUMPER. Quadricycle damage or tip over may result causing severe injury or death. Tow only from tow hooks or hitch.

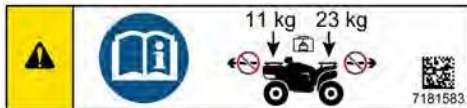

Maximum Rack Loads: Front 11 kg. Rear 23 kg.

CLUTCH COVER ALERT

⚠ WARNING

Keep body parts away from belt.



SAFETY

TIRE PRESSURE ALERT

SCRAMBLER XP 1000

⚠ WARNING

TIRE PRESSURE IN Bar:

- FRONT – (0.7 bar)
- REAR – (0.9bar)

Maximum Weight Capacity: 131 kg

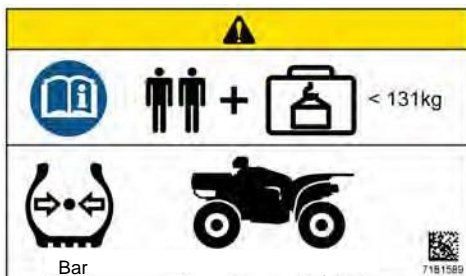

REAR HITCH SPECIFICATION

Maximum Vertical Load on Hitch	40 Kg
Maximum Towable Mass	180 Kg

REAR HITCH CERTIFICATION LABEL

Read the specification on the Hitch Installed on your Quadricycle

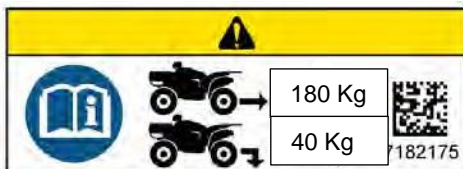

RADIATOR CAP WARNING**▲ WARNING**

Hot pressurized fluid can cause serious burns. Do not touch radiator cap when hot. Open slowly.



SCRAMBLER SWITCHES

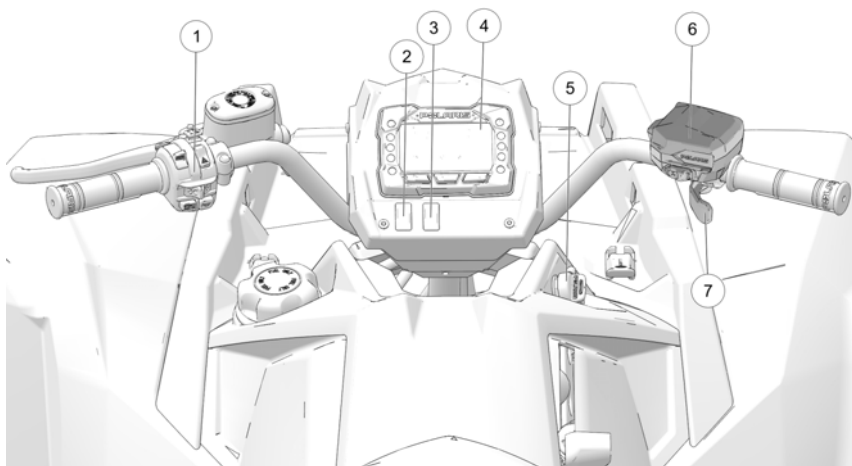

① Left Handlebar Controls

② Work Light Switch (if equipped)

③ Fog Light Switch (if equipped)

④ Digital Display

⑤ Ignition Switch



⑥ 4X4 Switch

⑦ Throttle Switch

IGNITION SWITCH

⚠ WARNING

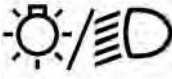
Do not attach a large key fob or key ring to the main switch. It may contact the gas tank cap when turning, causing an interruption to the electrical system and an unexpected engine shutdown during operation. This could result in serious injury or death.

SWITCH POSITION	FUNCTION
	<p>End all electrical power to the Quadricycle</p>
	<p>The LIGHTS ON position turns the headlights on. The engine stop switch must be in the RUN position.</p>
	<p>Start the engine. The headlights are not on in this position.</p>
	<p>After starting the engine, release the key switch to the PARKING LIGHTS ON position. The parking lights and taillights are on in this position.</p>

FEATURES AND CONTROLS

LEFT-HAND CONTROL



ENGINE STOP SWITCH

NOTICE

The engine will not start or run when the switch is in the OFF position.

Push the stop switch down to stop the engine quickly. Pull the stop switch up to the RUN position before attempting to start the engine.

Both the main switch and the engine stop switch will shut off all electrical power to the Quadricycle, including lights.

SWITCH POSITION	FUNCTION
	OFF
	RUN

HAZARD WARNING SWITCH

Push the hazard warning switch to cause all turn signal lights to flash simultaneously. Use this feature to alert others of an emergency or other situation requiring caution.

HORN SWITCH

Press the horn switch to sound the horn.

MODE / REVERSE OVERRIDE SWITCH

This Quadricycle is equipped with a reverse speed limiter system. To gain additional wheel speed while backing, release the throttle and depress the override switch.

WARNING

Pressing the override switch while the throttle is open can cause loss of control, which may result in serious injury or death. Always release the throttle before pressing the override switch.



The reverse override switch also acts as a MODE button when held down for approximately one half second. The transmission cannot be in reverse when using the override switch as a MODE button.

TURN SIGNAL SWITCH

Push the toggle switch either left or right to activate the corresponding turn signal light. The indicator in the gauge will also flash. Return the toggle to the center position and push it inward to end the signal.

HEADLIGHT AND MOMENTARY HIGH BEAM SWITCH

The lights do not operate unless the main key switch is on and the engine stop switch is in the RUN position.

SWITCH POSITION	FUNCTION
	High Beam
	Low Beam

Press this switch with your left forefinger to activate the headlight high beam. The lights will return to low beam when the switch is released.

FEATURES AND CONTROLS

RIGHT-HAND CONTROL

THROTTLE LEVER

WARNING

Operating an QUADRICYCLE with sticking or improperly operating throttle controls could cause an accident. Never start or operate an QUADRICYCLE that has a sticking or improperly operating throttle. Immediately contact your EGIMOTORS dealer or other qualified person for service if throttle problems arise.

Failure to check or maintain proper operation of the throttle system can result in an accident if the throttle lever sticks during operation. Always check the lever for free movement and return before starting the engine. Also check occasionally during operation.

Engine speed and Quadricycle movement are controlled by pressing the throttle lever ①. The throttle lever is spring loaded. Engine speed returns to idle when the lever is released.

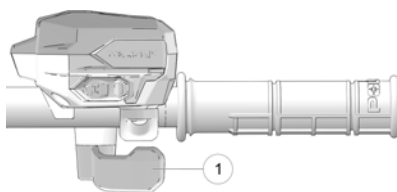

WARNING

Modifications to the electronic throttle control could result in failure to perform as designed, which could result in an accident. Do not attempt to modify the throttle control system or replace it with any after market throttle mechanisms.

DRIVELINE MODE SWITCH

The driveline mode switch ① controls the All Wheel Drive (AWD) system. Use this switch to change the driveline modes between Turf Mode, 2WD, AWD, and ADC. The Quadricycle automatically engages AWD when operating in reverse if the driveline mode is set to AWD.

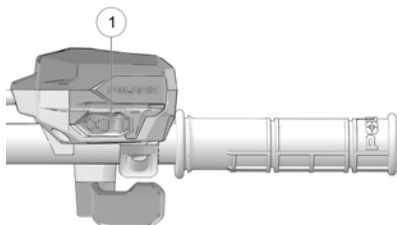

WORK LIGHT SWITCH (IF EQUIPPED)

The work light switch controls a light located in the pod. Use the light when additional light is needed at the front of the Quadricycle, but turn the work light off when driving the Quadricycle (on-road).

BRAKES

CAUTION

Aggressively applying the brakes when backing down a hill may cause rear tip-over. Aggressively applying the brakes while moving forward may cause the rear wheels to skid and result in loss of control.

Read this owner's manual and understand the operation of all brake systems on this Quadricycle. Always use caution whenever applying the brakes.

AUXILIARY FOOT BRAKE

WARNING

Use caution when applying the auxiliary brake. Do not aggressively apply the auxiliary brake. The wheels may skid and slide sideways, causing loss of control and serious injury or death.

The auxiliary brake system is intended to be used as a backup for the main brake system. Should the main system fail, use the auxiliary foot brake ①.

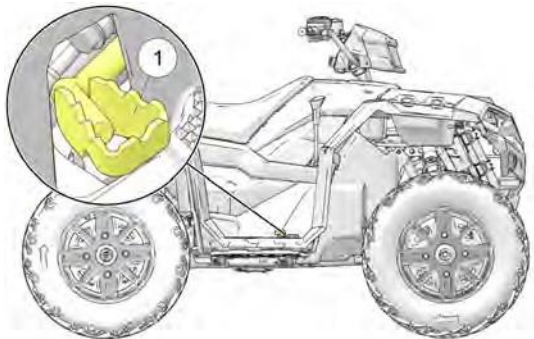

The auxiliary foot brake is located on the inside of the right footrest. Operate this brake with your right foot. If the wheels slide while using the auxiliary brake, *reduce* brake pedal pressure to brake the wheels without skidding.

FEATURES AND CONTROLS

HAND BRAKE LEVER

The hand brake ① operates both front and rear brakes. Squeeze the brake lever toward the handlebar to apply the all-wheel brakes. If the rear wheels begin to skid or slide while using the brake, reduce lever pressure.

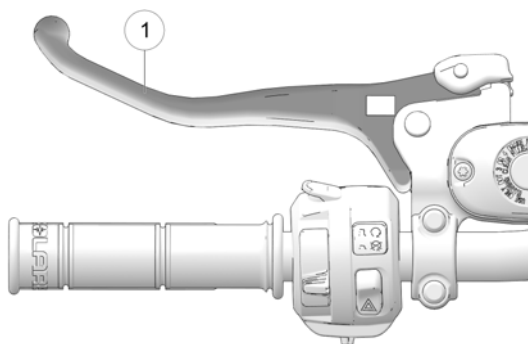

CAUTION

Operating the Quadricycle with a spongy brake lever can result in loss of braking, which could cause an accident.

Never operate the Quadricycle with a spongy-feeling brake lever.
Always contact your dealer for service before operating the Quadricycle.

BRAKE HOLDING LATCH

WARNING

Operating the QUADRICYCLE while the brake holding latch is engaged could result in an accident or fire. Always check to be sure the latch is disengaged before operating.

To lock the parking brake, do the following:

1. Place the transmission in PARK.
2. Squeeze and release the brake lever ① two or three times, then squeeze and hold.
3. Push the brake holding latch ② forward to engage the lock.
4. Release the brake lever.

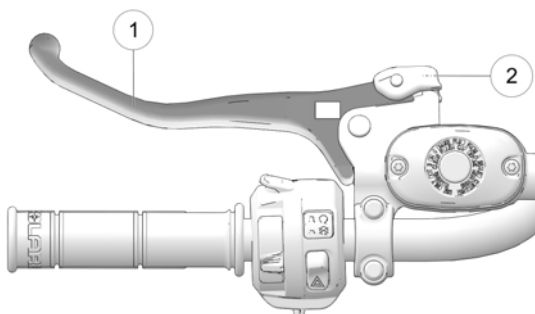

5. To release the brake holding latch, squeeze and release the brake lever. It will return to its unlocked position.

NOTICE

The brake holding latch may relax if left on for a long period of time. Always block the wheels to prevent rolling. Always block the wheels on the downhill side of the QUADRICYCLE if leaving it parked on a hill. Another option is to park the QUADRICYCLE in a sidehill position. Never depend on the brake holding latch alone if the QUADRICYCLE is parked on a hill. Always block the wheels to prevent rolling.

AUTOMATIC TRANSMISSION GEAR SELECTOR

The transmission gear selector ① is located on the right side of the Quadricycle.

- H: High Gear
- L: Low Gear
- N: Neutral
- R: Reverse
- P: Park

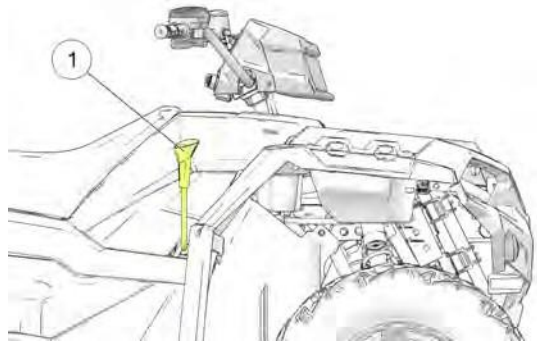

To shift gears, brake to a complete stop. When the engine is idling, move the lever to the desired gear.

NOTE

Shifting gears with the engine speed above idle or while the Quadricycle is moving could cause transmission damage.

Whenever the QUADRICYCLE is left unattended, always place the transmission in PARK and lock the parking brake.

BELT LIFE

To extend belt life, use low forward gear when pulling a heavy load at less than 11 km/h for extended periods and when operating uphill at a slow speed.

FEATURES AND CONTROLS

FUEL CAP

Always refuel with the engine stopped, and outdoors or in a well ventilated area. Refuel on a level surface.

Remove the fuel tank cap

① and add fuel. Only use unleaded gasoline with a minimum pump octane number of $87 = (R + M) / 2$ octane. Do not use fuel with ethanol content greater than 10%, such as E-85 fuel.

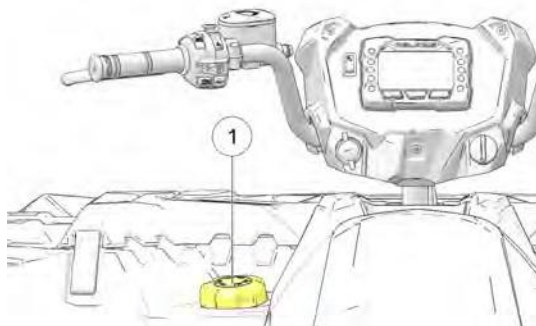

The fuel tank is designed to allow for the normal expansion of fuel. Do not overfill. Do not fill the tank neck.

BATTERY ISOLATOR / BATTERY QUICK DISCONNECT

The battery isolator provides a quick and easily accessible method of disconnecting the battery and removing all power from the Quadricycle if the need should arise.

The isolator is located in the front compartment.

1. Remove the front rack or box. See the Front Rack section of this chapter for instructions.
2. Turn the isolator switch counter-clockwise 90° to the OFF position ①.



EXTREME USE BATTERY

An optional extreme use battery may be available for your model. If the performance of the factory-installed battery is inadequate due to operation in extreme cold or due to extended use of multiple electrical accessories, your EGIMOTORS dealer can assist. Your dealer can provide any installation procedures that may differ for an extreme use battery.

MIRRORS

Use the mirrors located on each side of the Quadricycle to assist in traffic maneuvers. Always check and adjust the mirrors before driving the Quadricycle.

ELECTRONIC POWER STEERING (EPS)

Electronic power steering (EPS), if equipped, engages when the ignition key is turned to the ON position. EPS remains engaged whether the Quadricycle is moving or idle. See the Instrument Cluster section for EPS Warning Indicator information.

SCRAMBLER MODELS

FRONT RACK

Release the front rack latches ① and remove the rack to gain access to the front compartment. To reinstall the rack, hold the rack as shown. Position the front edge in the tabs, then push the rack downward and secure the latches.

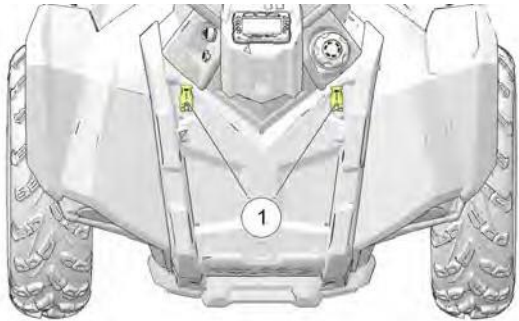

FEATURES AND CONTROLS

FRONT COMPARTMENT

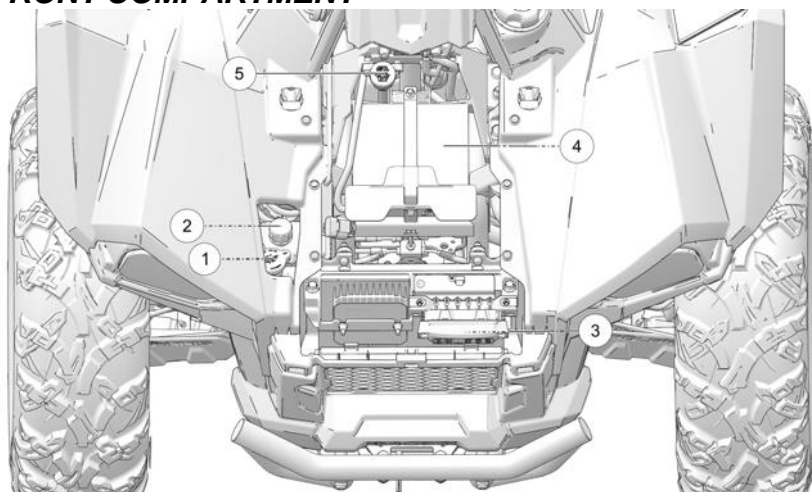

- ① Radiator Cap
- ② Coolant Bottle Cap
- ③ Electrical/Fuse/Relay
- ④ Battery
- ⑤ Brake Fluid Reservoir

HITCHES

See the Specifications Section for hitch weight capacities.

NOTICE

Do not tow a Quadricycle or a trailer with this Quadricycle unless all instructions have been followed. See the Hauling Cargo section for details.

CAUTION

Whenever the Quadricycle is towing, always stay clear of the area between the Quadricycle and the towed object.

REAR HITCH

NOTICE

After 1000 km of use, tighten the bolt holding the trailer ball to the hitch to 445 N·m.

Use the rear hitch for towing a trailer. See the Hauling Cargo section for details and procedures.

The values given below pertain to factory-installed hitches and are provided for informational purposes only.

IMPORTANT

For Quadricycle-specific trailering values, see the Specifications chapter. The Quadricycle-specific values take precedent if they are lower than the component values shown below.

REAR HITCH COMPONENT SPECIFICATIONS

Maximum Vertical Load (S)	40 kg
Maximum Towable Mass	160 kg

7-WAY TRAILER CONNECTOR

The 7-way trailer connector ① installed on your Quadricycle meets the requirements of European standard ISO 1724.

Improper electrical wiring changes can result in damage to both Quadricycle and trailer components. When in doubt about your trailer connection, please contact a qualified towbar specialist for assistance.

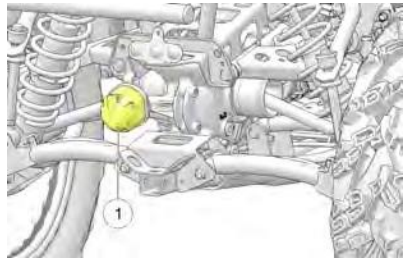

FEATURES AND CONTROLS

INSTRUMENT CLUSTER

OVERVIEW

NOTICE

Features and telltales vary by model.

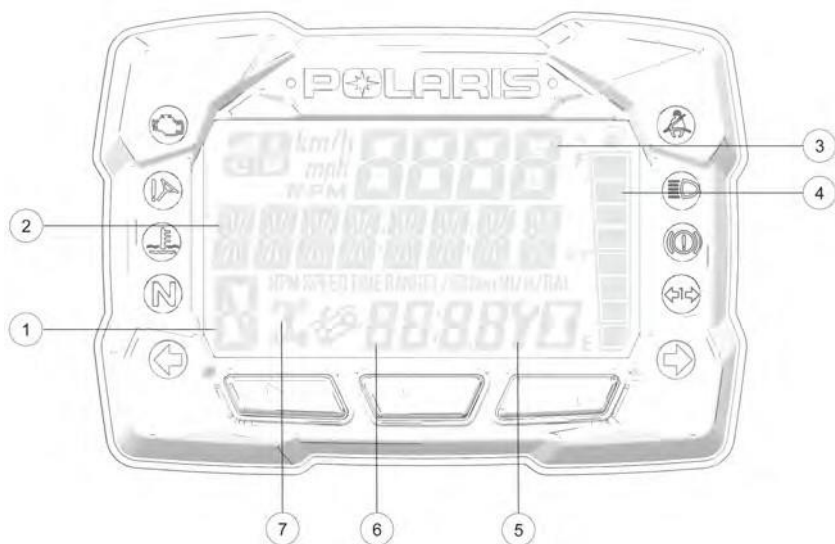





DISPLAY AREA	FUNCTION
① Gear Indicator	H = High Gear L = Low Gear N = Neutral R = Reverse Gear P = Park - = Gear Signal Error (or shifter between gears)
② Display Area 2	This area displays odometer, trip meter, trip meter 2, voltage, engine temperature, engine hour meter, programmable service hour interval, ground speed, or engine RPM.
③ Display Area 1	This area displays engine RPM, ground speed, or coolant temperature.
④ Fuel Gauge	The segments of the fuel gauge show the level of fuel in the fuel tank. When the last segment clears, a low fuel warning is activated. All segments including the fuel icon will flash. Refuel immediately.



FEATURES AND CONTROLS

DISPLAY AREA	FUNCTION
⑤ Service Indicator	A flashing wrench symbol alerts the operator that the preset service interval has been reached. Your EGIMOTORS dealer can provide scheduled maintenance. See page 62 for more information.
⑥ Clock	The clock displays time in a 12-hour or 24-hour format.
⑦ Driveline Mode Indicator	Segments of the indicator illuminate based on driveline mode engaged.

INDICATOR LAMPS

INDICATOR	ICON	FUNCTION
Check Engine		This indicator appears if a fault occurs. Do not operate the Quadricycle if this warning appears. Serious engine damage could result. Your authorized EGIMOTORS dealer can assist.
EPS Warning (if equipped)		This indicator illuminates when a fault has occurred in the EPS system. Your authorized EGIMOTORS dealer can assist. EPS operation is possible with key on/engine off for up to 5 minutes.
Engine Hot		This lamp illuminates to indicate an overheated engine. If the indicator flashes, a severe overheating condition exists.
Neutral		This lamp illuminates when the transmission is in neutral and the ignition key is in the ON position.
Helmet/Seat Belt		This lamp flashes for several seconds when the key is turned to the ON position. The lamp is a reminder to wear helmet and seat belt (if equipped) before operating.

FEATURES AND CONTROLS

INDICATOR	ICON	FUNCTION
High Beam		This lamp illuminates when the headlamp switch is set to high beam.
Trailer Indicator		The Turn Trailer Indicator is illuminating when the trailer turn signals are active.

FEATURES AND CONTROLS

DISPLAY AREA 1

Pressing the MODE button will change the information displayed in Area 1 ①.



DISPLAY AREA 1	FUNCTION
Speed	The Quadricycle's speed will be displayed in mph, or km/h.
Engine Temperature	The Quadricycle's current engine temperature will be displayed.
RPM	The Quadricycle's RPM will be displayed.

DISPLAY AREA 2

Toggle the Up/Down buttons to change the information displayed in Area 2 ②.



DISPLAY AREA 2	FUNCTION
Odometer	The Quadricycle's odometer reading will be displayed.
Engine Temperature	The Quadricycle Engine Temperature will be displayed.
Trip 1	The Quadricycle Trip 1 mileage will be displayed.
Trip 2	The Quadricycle Trip 2 mileage will be displayed.
RPM	The Quadricycle RPM will be displayed.
Voltage	The Quadricycle's current battery voltage will be displayed.
Speed	The Quadricycle's current speed will be displayed.
Engine Hours	The Quadricycle's engine hours will be displayed.
Service Hours	The Quadricycle's service hours will be displayed.

FEATURES AND CONTROLS

OPTIONS MENU

From the options menu you can view diagnostic codes, access the advanced menu, set the clock, and much more. For a full list of available options see below.

To enter the Options Menu, press and hold the MODE button.



OPTIONS MENU	NOTES
Electronic Power Steering (EPS)	Turn EPS feature on/off and set between high or low.
Diagnostic Codes	Only displays if fault codes are present or stored
Advanced Menu (if equipped)	Set maximum speed, and geofencing settings.
Units - Distance	Select MPH or KPH
Units - Temp	Select between °F and °C
Clock (if equipped)	Select between 12H or 24H, and set time
Backlight Color	Select between Blue or Red
Backlight Level	Set backlight brightness level
Service Hours	View/Set Service hours
Exit Menu	Exit

ELECTRONIC POWER STEERING (EPS)

Electronic power steering (EPS), if equipped, engages when the ignition key is turned to the ON position. EPS remains engaged whether the Quadricycle is moving or idle. See the Instrument Cluster section for EPS Warning Indicator information.

NOTICE

Never switch EPS modes while the Quadricycle is in motion. Ensure the Quadricycle is fully stopped and no force is applied to the steering system before switching EPS modes.

EPS has three modes: high, medium, low. To set the EPS mode, do the following.

1. Stop the QUADRICYCLE and put it in PARK.
2. Press and hold the MODE button to enter the Options Menu. "OPTIONS" will display on the screen for 3 seconds before showing the first menu item.
3. Select "EPS" from the Options Menu by pressing the MODE button.
4. Toggle the Up/Down Buttons to choose between the high, medium, and low modes.
5. Press the MODE button to lock in the EPS setting.



FEATURES AND CONTROLS

DIAGNOSTIC CODE

Diagnostic Code Screen will show available MIL that has come on during that ignition cycle.

To access the Diagnostic Code Screen, do the following:

1. Press and hold the MODE button to enter the Options Menu. "OPTIONS" will display on the screen for 3 seconds before showing first menu item.
2. Select "Diagnostic Codes" from the Options Menu by pressing the MODE button.

Toggle the Up/Down Buttons to cycle through Code(s).

NOTICE

This option will only be available if a fault code was set or is active during the current ignition key 'on' cycle. Turning off the ignition will clear any save fault codes from the gauge.

- ① Display area 1 will show FMI
- ② Display area 2 will show SPN
- ③ Clock Area will show Count.

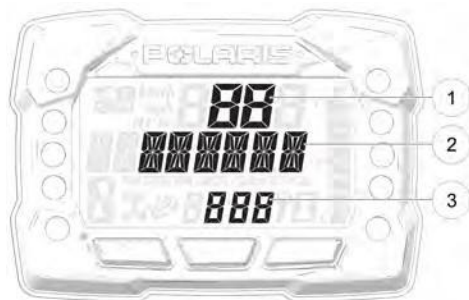

NOTICE

When the gauge is displaying a fault code, the warning telltale (check engine or EPS) will blink to indicate which controller set the fault code.

- To exit the Options Menu the user can select Exit Menu function from Options Menu, can hold Mode Button and exit out of Options Menu, or not press any button for 10 seconds, which will exit out of the Options Menu.

UNIT SELECTION DISTANCE

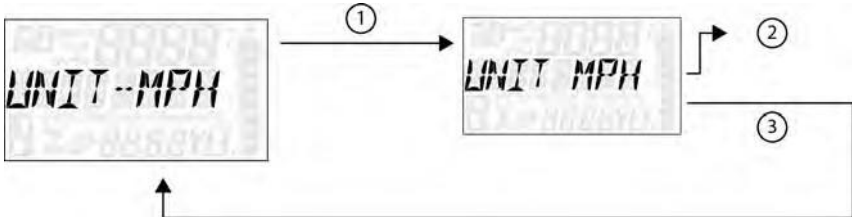

- Press and hold the MODE button to enter the Options Menu.

NOTICE

“OPTIONS” will display on the screen for 3 seconds before showing first menu item.

- Select “Units-Distance” from the Options Menu by pressing the MODE button.

Reference the image shown above:

- Press the MODE button.
 - Toggle the Up/Down Buttons to change the units (MPH or KPH)
 - With the correct unit displayed, Press the mode button which will set the unit and return to the Options Menu.
- To exit the Options Menu the user can select Exit Menu function from Options Menu, can hold Mode Button and exit out of Options Menu, or not press any button for 10 seconds, which will exit out of the Options Menu.

UNIT SELECTION TEMPERATURE

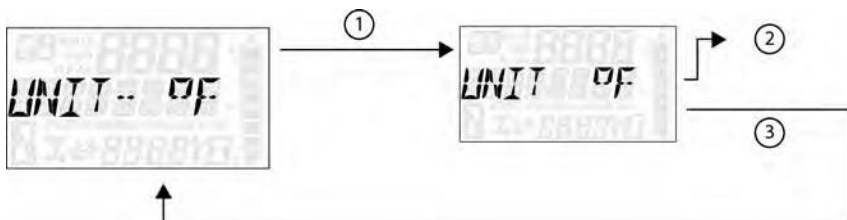

1. Press and hold the MODE button to enter the Options Menu.

NOTICE

"OPTIONS" will display on the screen for 3 seconds before showing first menu item.

2. Select "Units - Temp" from the Options Menu by pressing the MODE button.
Reference the image shown above:
 - ① Press the MODE button.
 - ② Toggle the Up/Down Buttons to change the units (°F or °C)
 - ③ With the correct unit displayed, Press the mode button which will set the unit and return to the Options Menu.
3. To exit the Options Menu the user can select Exit Menu function from Options Menu, can hold Mode Button and exit out of Options Menu, or not press any button for 10 seconds, which will exit out of the Options Menu.

CLOCK

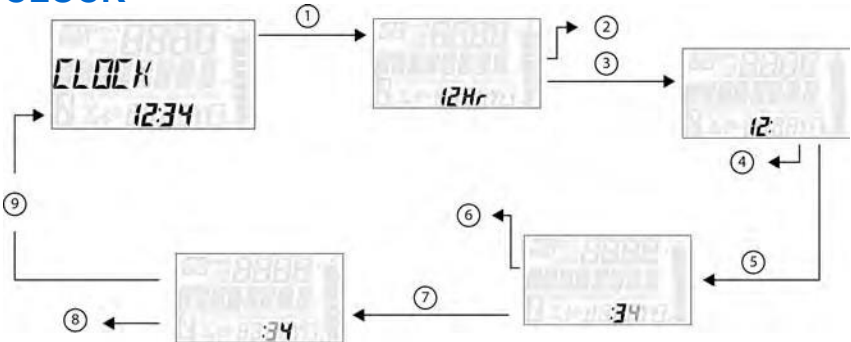

1. Press and hold the MODE button to enter the Options Menu.

NOTICE

“OPTIONS” will display on the screen for 3 seconds before showing first menu item.

2. Select “Clock” from the Options Menu by pressing the MODE button.

Reference the image shown above:

- ① Press the MODE button.
 - ② Toggle the Up/Down Buttons to change the units (12H or 24H)
 - ③ With the correct unit displayed, Press the mode button which will set the unit.
 - ④ Toggle the Up/Down Buttons to change the units (Cycles Hours)
 - ⑤ With the correct unit displayed, Press the mode button which will set the unit.
 - ⑥ Toggle the Up/Down Buttons to change the units (Cycles 10s of Minutes)
 - ⑦ With the correct unit displayed, Press the mode button which will set the unit.
 - ⑧ Toggle the Up/Down Buttons to change the units (Cycles 1s of Minutes)
 - ⑨ With the correct unit displayed. Press the mode button which will set the unit and return to the Options menu.
3. To exit the Options Menu the user can select Exit Menu function from Options Menu, can hold Mode Button and exit out of Options Menu, or not press any button for 10 seconds, which will exit out of the Options Menu.

FEATURES AND CONTROLS

BACK LIGHT COLOR

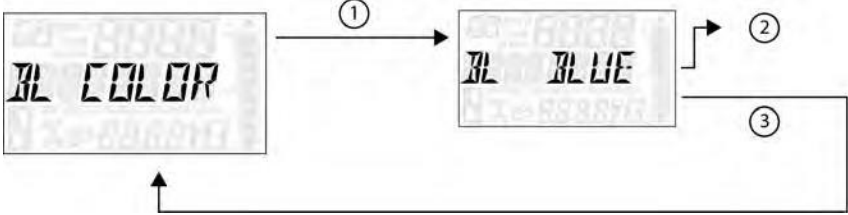

1. Press and hold the MODE button to enter the Options Menu.

NOTICE

"OPTIONS" will display on the screen for 3 seconds before showing first menu item.

2. Select "Backlight Color" from the Options Menu by pressing the MODE button.

Reference the image shown above:

- ① Press the MODE button.
 - ② Toggle the Up/Down Buttons to change the units (Blue or Red)
 - ③ With the correct unit displayed, Press the mode button which will set the unit and return to the Options Menu.
3. To exit the Options Menu the user can select Exit Menu function from Options Menu, can hold Mode Button and exit out of Options Menu, or not press any button for 10 seconds, which will exit out of the Options Menu.

BACK LIGHT LEVEL

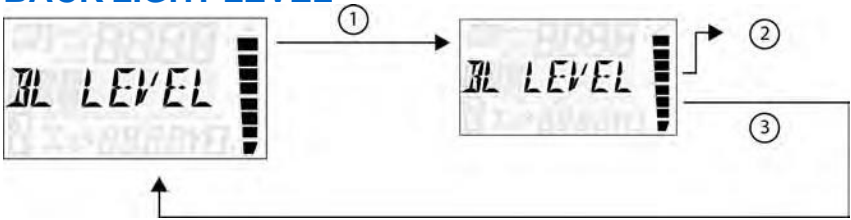

1. Press and hold the MODE button to enter the Options Menu.

NOTICE

“OPTIONS” will display on the screen for 3 seconds before showing first menu item.

2. Select “Backlight Level” from the Options Menu by pressing the MODE button.

Reference the image shown above:

- ① Press the MODE button.
- ② Toggle the Up/Down Buttons to change the units (Increase or Decrease Level)
- ③ With the correct unit displayed, Press the mode button which will set the unit and return to the Options Menu.

3. To exit the Options Menu the user can select Exit Menu function from Options Menu, can hold Mode Button and exit out of Options Menu, or not press any button for 10 seconds, which will exit out of the Options Menu.

FEATURES AND CONTROLS

SERVICE HOURS

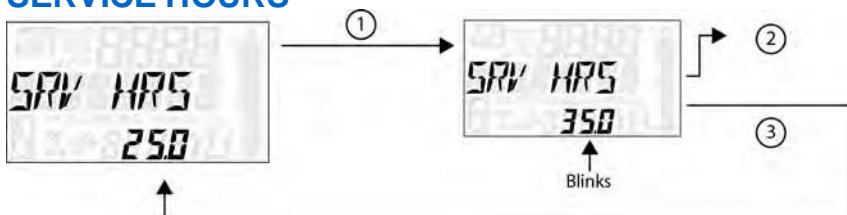

1. Press and hold the MODE button to enter the Options Menu.

NOTICE

"OPTIONS" will display on the screen for 3 seconds before showing first menu item.

2. Select "Service Hours" from the Options Menu by pressing the MODE button.

Reference the image shown above:

- ① Press the MODE button.
- ② Toggle the Up/Down Buttons to change the units (0, 5, 10 - 95, 100)
- ③ With the correct unit displayed, press the MODE button, which will set the unit and return you to the Options Menu.

NOTICE

To reset service hours after they have counted down to "0.0", reselect the existing setpoint or select a new service hour value.

3. To exit the Options Menu the user can select Exit Menu function from Options Menu, can hold Mode Button and exit out of Options Menu, or not press any button for 10 seconds, which will exit out of the Options Menu.

BLUETOOTH® (IF EQUIPPED)

The Bluetooth® functionality allows users to pair their phones with the Quadricycle's digital gauge. This function allows users to receive call and text alerts while operating the Quadricycle.

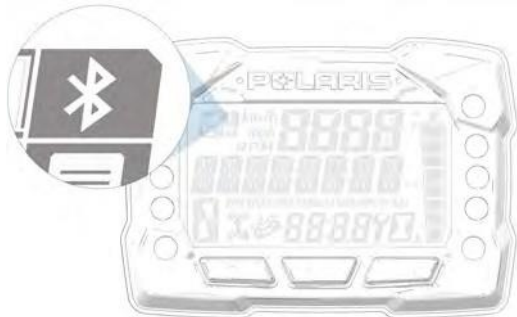

If a text message is received while the Quadricycle is moving faster than 2 KPH, only the sender's name is shown onscreen.

If you are browsing any of the Bluetooth® menus and the Quadricycle starts to move faster than 2 KPH, the menu will automatically display *QUADRICYCLE MOVING*. If you attempt to access Bluetooth® menus while the Quadricycle is moving faster than 2 KPH, the screen will display *QUADRICYCLE MOVING* momentarily, and then it will redirect to the options menu.

PAIRING YOUR PHONE TO THE GAUGE

Use the following procedure to pair your phone with the Quadricycle's digital gauge.

NOTICE

Bluetooth® functionality is compatible with both iOS® and Android® phones. For iOS® phones, you must go to the Settings option and enable notifications. Most Android® phones will prompt the user automatically to enable notifications as part of the pairing process.

1. Make sure Bluetooth® is enabled on your phone.
2. Access the options menu on the Quadricycle's digital gauge and select *BT PAIR*. The Bluetooth® icon will begin to blink.
3. Find and select *Egimotors Gauge* on your phone's Bluetooth® menu or prompt. Pairing should occur momentarily. Pairing mode will continue for up to 90 seconds or if you exit the *BT PAIR* menu.

After successfully pairing the phone, the Quadricycle's digital gauge will automatically reconnect with the phone each time it is powered on and within range. No further action is required by the user at this point.

FEATURES AND CONTROLS

ALL WHEEL DRIVE SYSTEM

NOTICE

Switching to AWD while the rear wheels are spinning may cause severe drive shaft and gearcase damage. Always switch to AWD while the rear wheels have traction or are at rest.

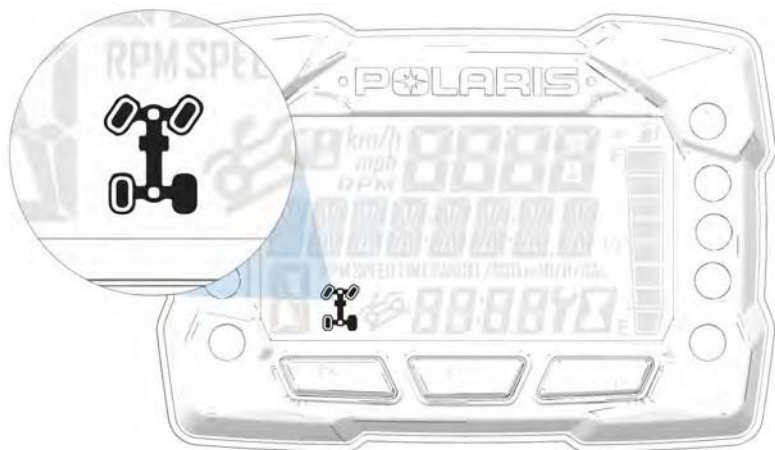

The All Wheel Drive system is controlled by the Driveline switch. See page 40. Engage AWD before getting into conditions where front wheel drive may be needed. If the rear wheels are spinning, release the throttle before switching to AWD.

AWD MODE

Move the momentary Driveline switch to the far right to engage AWD. AWD will engage when engine speed slows to below 3100 RPM. The gauge will display "AWD". There is no limit to the length of time the Quadricycle may remain in AWD. The Quadricycle automatically engages AWD when operating in reverse if the switch is set to the AWD position.



Once enabled, AWD remains enabled until the switch is turned off. If the switch is turned off while the demand drive unit is moving, it will not disengage until the rear wheels regain traction.

When in AWD, the demand drive unit will automatically engage any time the rear wheels lose traction. When the rear wheels regain traction, the demand drive unit will automatically disengage.

2X4 MODE

Move the momentary switch to the far left to operate in two-wheel drive. AWD will disengage when engine speed slows to below 3100 RPM. The gauge will display "2X4".



FEATURES AND CONTROLS

REAR DIFFERENTIAL

The function of the differential is to have a choice depending on the kind of use you are doing.

ENGAGED: the wheels are rotating at the same speed (green light on)

DISINGAGED: the wheels are rotating independently one of the other

A Disengaged Differential gives a better drivability of your Quadricycle especially when turning by allowing the inside wheel to rotate slower than the outside wheel when turning.

If you need to make sharp turns on hard surface or grass without damages this is the right option to use.

In case of a lack of traction it's recommended to engage the differential in order to let the two wheels rotating at the same speed.

This is to be used for offroad situation only.

How does it work?

By default, the differential is disengaged, and the two wheels rotate at different speed: TURF MODE

When the Key is turned ON the green light on the dashboard will automatically turn on, after 3 seconds the light will turn off. (Light check)



FEATURES AND CONTROLS

If you want to **lock** the rear differential in order to have the two wheels rotating at the same speed, you need to:

Stop Driving the unit in a safe area

Put the shift lever on Parking " P "

Move the YELLOW switch to the right for 3 seconds and release it.

The green light on the dashboard will turn ON.

Now you can engage by moving the shift lever to the desired riding position:



H :High Gear
L :Low Gear
N :Neutral
R :Reverse
P :Park

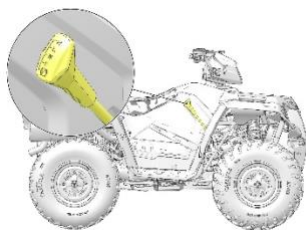

If you want to **unlock** the rear differential in order to let the two wheels rotating at different speed, you need to:

Stop Driving the unit in a safe area

Put the shift lever on Parking " P "

Move the YELLOW switch to the left for 3 seconds and release it.

The green light on the dashboard will turn OFF.



FEATURES AND CONTROLS

FOUR-WHEEL DESCENT CONTROL (IF EQUIPPED)

NOTICE

Switching to 4WDC while the rear wheels are spinning may cause severe drive shaft and gearcase damage. Always switch to 4WDC while the rear wheels have traction or are at rest.

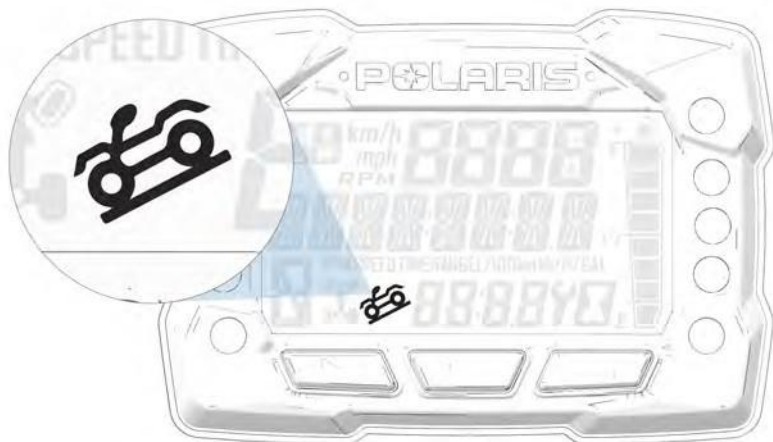

The Four-Wheel Decent Control (4WDC) system allows engine braking to all four wheels when the Quadricycle descends a hill or incline. Always engage 4WDC mode (if equipped) before ascending or descending a hill.

ENGAGING FOUR-WHEEL DESCENT CONTROL

The 4WDC system will automatically engage when *all* of the following conditions occur:

- 4WDC is engaged
- The throttle must be closed (throttle lever released)
- The transmission must be in gear (high, low or reverse)

DISENGAGING FOUR-WHEEL DESCENT CONTROL

The 4WDC system will automatically disengage if *at least one* of the following conditions occur:

- The 4X4 switch is moved out of the 4WDC position
- The throttle is open (throttle is applied)
- The transmission is shifted to neutral or park
- The Quadricycle is on flat ground, or not actively descending a hill

OPERATION

SAFE OPERATION PRACTICES

**WARNING**

Failure to operate the Quadricycle properly can result in a collision, loss of control, accident or rollover, which may result in serious injury or death. Read and understand all safety warnings outlined in the safety section of this owner's manual.

1. Complete the recommended safety training before operating this Quadricycle. Visit www.Quadricyclesafety.org for safety courses and riding tips. See page 11 for details.
2. Do not allow anyone under 16 years of age to operate this Quadricycle. Do not allow anyone with cognitive or physical disabilities to operate this Quadricycle.
3. Never carry a passenger on a 1-up QUADRICYCLE. Never carry more than one passenger on a 2-up QUADRICYCLE.
4. Engine exhaust fumes are poisonous. Never start the engine or let it run in an enclosed area.
5. Before operating, learn how to use the auxiliary brake for emergency situations (if service brakes become inoperable).
6. Use caution and drive at reduced speeds in conditions of reduced visibility such as fog, rain and darkness. Clean headlights frequently and replace burned out headlamps promptly.
7. Drive in a manner appropriate for your skills, your passenger's skills and operating conditions. Never operate at excessive speeds. Never attempt wheelies, jumps, or other stunts. Never remove your hands from the handlebars while operating, and always keep both feet on the footrests.
8. Never consume alcohol or drugs before or while operating an QUADRICYCLE.
9. Always use the size and type of tires specified for your Quadricycle. Always maintain proper tire pressure.
10. Never operate a damaged QUADRICYCLE. After any overturn or accident, have a qualified service dealer inspect the entire machine for possible damage.
11. Never operate the QUADRICYCLE on a frozen body of water unless you have independently verified that the ice is sufficiently thick to support the weight and moving force of the QUADRICYCLE, you and your cargo, together with any other Quadricycles in your party.

OPERATION

12. Do not touch hot exhaust system components. Always keep combustible materials away from the exhaust system.
13. Always remove the ignition key when the Quadricycle is not in use to prevent unauthorized use.

TRAIL ETIQUETTE

Always practice good etiquette when riding. Allow a safe distance between your Quadricycle and other Quadricycles operating in the same area. Communicate to oncoming operators by signaling the number of Quadricycles in your group. When stopping, move your Quadricycle to the edge of the trail as far as possible to allow others to pass safely.

KNOW YOUR RIDING AREA/TREAD LIGHTLYSM

Familiarize yourself with all laws and regulations concerning the operation of this Quadricycle in your area. Respect the environment in which you ride your Quadricycle.

Find out where the designated riding areas are by contacting your EGIMOTORS dealer, a local riding club, or local officials.

Help keep our trails open for recreational Quadricycle use. As an off-road enthusiast, you represent the sport and can set a good example (or a poor example) for others to follow. Tread LightlySM. Operate with respect for the terrain, avoid littering, and always stay on the designated trails.

QUADRICYCLE BREAK-IN PERIOD

The break-in period for your new EGIMOTORS Quadricycle is the first 25 hours of operation, or the time it takes to use the first two tanks full of gasoline. No single action on your part is as important as a proper break-in period. Careful treatment of a new engine and drive components will result in more efficient performance and longer life for these components. Perform the following procedures carefully.

NOTICE

Excessive heat build-up during the first three hours of operation will damage close-fitted engine parts and drive components. Do not operate at full throttle or high speeds during the first three hours of use.

Use of any improper oils may cause serious engine damage. EGIMOTORS PS-4 Full Synthetic 5W-50 4-Cycle Oil is specifically formulated for your 4-cycle engine.

ENGINE AND DRIVETRAIN BREAK-IN

1. Fill the fuel tank with gasoline. See the Fuel Tank section for details. Always exercise extreme caution whenever handling gasoline.
2. Check the oil level. See the Oil Check section for reference. Add the recommended oil as needed to maintain the oil level in the safe operating range.
3. Drive slowly at first. Select an open area that allows room to familiarize yourself with Quadricycle operation and handling.
4. Avoid aggressive use of the brakes.
5. Vary throttle positions. Do not operate at sustained idle.
6. Pull only light loads.
7. Perform regular checks on fluid levels, controls and areas outlined on the daily pre-ride inspection checklist.
8. During the break-in period, change both the oil and the filter at 25 hours or 250 miles.
9. Check fluid levels of transmission and all gearcases after the first 25 hours of operation and every 100 hours thereafter.

BRAKE SYSTEM BREAK-IN

Apply only moderate braking force for the first 50 stops. Aggressive or overly forceful braking when the brake system is new could damage brake pads and rotors.

PVT BREAK-IN (CLUTCHES/BELT)

Always break in the clutches and drive belt of new Quadricycles, as well as after a belt replacement.

A proper break-in of the clutches and drive belt will ensure a longer life and better performance. Break in the clutches and belt by operating at slower speeds during the break-in period as recommended. Pull only light loads. Avoid aggressive acceleration and high speed operation during the break-in period.

If a belt fails, always clean any debris from the PVT intake and outlet duct and from the clutch and engine compartments when replacing the belt.

OPERATION

PRE-RIDE CHECKLIST

Failure to inspect and verify that the QUADRICYCLE is in safe operating condition before operating increases the risk of an accident. Always inspect the QUADRICYCLE before each use to make sure it's in safe operating condition.

ITEM	REMARKS
Brake system/lever travel	Ensure proper operation
Brake fluid	Ensure proper level
Auxiliary brake	Ensure proper operation
Front suspension	Inspect, lubricate if necessary
Rear suspension	Inspect, lubricate if necessary
Steering	Ensure free operation
Tires	Inspect condition and pressure
Wheels/fasteners	Inspect, ensure fastener tightness
Frame nuts, bolts, fasteners	Inspect, ensure tightness
Fuel and oil	Ensure proper levels
Coolant level	Ensure proper level
Coolant hoses	Inspect for leaks
Throttle	Ensure proper operation
Indicator lights/switches	Ensure operation
Engine stop switch	Ensure proper operation
Air filter, pre-filter	Inspect, clean

ITEM	REMARKS
Headlamp	Check operation
Brake light/taillight	Check operation
Riding gear	Wear approved helmet, goggles, and protective clothing
Winch (if equipped)	Inspect cable and switch
Grass and leaves	Remove grass, leaves, foreign matter, and other flammable material or debris, especially near the exhaust system.

OPERATION

DRIVING PROCEDURES

NEW OPERATOR DRIVING PROCEDURES

1. Wear protective riding gear. See the Safe Riding Gear section.
2. Perform the pre-ride inspection.

3. Place the transmission in PARK.

4. Lock the brake holding latch.

5. Mount the Quadricycle from the left side.

6. Sit upright with both feet on the footrests and both hands on the handlebars.

7. Start the engine and allow it to warm up.



8. Shift the transmission into gear.

9. Check your surroundings and determine your path of travel.

10. Release the brake holding latch.

11. Slowly depress the throttle with your right thumb and begin driving.

12. Drive slowly. Practice maneuvering and using the throttle and brakes on level surfaces.

TURNING THE QUADRICYCLE

1. Slow down.
2. Never turn quickly when carrying cargo.
3. Steer in the direction of the turn.
4. Keep both feet on the footrests.
5. Lean your upper body to the inside of the turn while supporting your weight on the outer footrest. This technique alters the balance of traction between the rear wheels, allowing the turn to be made smoothly. The same leaning technique should be used for turning in reverse.
6. Practice making turns at slow speeds before attempting to turn at faster speeds.

**WARNING**

Turning improperly can result in Quadricycle overturn. Never turn abruptly or at sharp angles. Never turn at high speeds.

OPERATION

DRIVING ON SLIPPERY SURFACES

WARNING

Skidding or sliding can cause loss of control or rollover (if tires regain traction unexpectedly). When operating on slippery surfaces such as ice or loose gravel, reduce speed and use extra caution to reduce the chance of skidding or sliding out of control. Do not operate on excessively slippery surfaces.



Whenever riding on slippery surfaces such as wet trails or loose gravel, or during freezing weather, follow these precautions:

1. Do not operate on excessively rough, slippery or loose terrain.
2. Slow down when entering slippery areas.
3. Engage 4X4 before wheels begin to lose traction.

NOTICE

Severe damage to drive train may occur if the 4X4 is engaged while the wheels are spinning. Allow the rear wheels to stop spinning before engaging 4X4, or engage 4X4 before wheels begin to lose traction.

4. Maintain a high level of alertness, reading the trail and avoiding quick, sharp turns, which can cause skids.
5. Never apply the brakes during a skid. Correct a skid by turning the handlebars in the direction of the skid and shifting your body weight forward.

DRIVING UPHILL

Braking and handling are greatly affected when operating in hilly terrain. Improper procedure could cause loss of control or overturn. Whenever traveling uphill, follow these precautions:

1. Always engage 4WDC before ascending or descending a hill.
2. Drive straight uphill.
3. Avoid steep hills. **Maximum incline is: 15°**
4. Always check the terrain carefully before ascending any hill.
5. Never climb hills with excessively slippery or loose surfaces.
6. Keep both feet on the footrests.
7. Shift body weight uphill.
8. Proceed at a steady rate of speed and throttle opening. Opening the throttle suddenly could cause the QUADRICYCLE to flip over backwards.
9. Never go over the top of any hill at high speed. An obstacle, a sharp drop, or another Quadricycle or person could be on the other side of the hill.
10. Remain alert and be prepared to take emergency action. This may include quick dismounting of the Quadricycle.

DRIVING DOWNHILL



When driving downhill, follow these precautions:

1. Always check the terrain carefully before descending a hill.
2. Always engage 4WD or 4WDC mode (if equipped) before ascending or descending a hill.
3. Avoid steep hills. **Maximum incline is 15°**
4. Always descend a hill with the transmission in forward gear. Do not descend a hill with the transmission in neutral.
5. Slow down. Never travel down a hill at high speed.
6. Drive straight downhill. Avoid traveling down a hill at an angle, which would cause the Quadricycle to lean sharply to one side.
7. Shift body weight uphill.
8. Apply the brakes *slightly* to aid in slowing. Applying the brakes too firmly may cause the rear wheels to lock, which could result in loss of control.

DRIVING ON A SIDEHILL (SIDEHILLING)



Driving on a sidehill is not recommended. Improper procedure could cause loss of control or overturn. Avoid crossing the side of any hill unless absolutely necessary.

If crossing a sidehill is *unavoidable*, follow these precautions:

1. Slow down.
2. Avoid crossing the side of a steep hill.
3. Lean into the hill, transferring your upper body weight toward the hill while keeping your feet on the footrests.
4. If the Quadricycle begins to tip, quickly turn the front wheel downhill, if possible, or dismount on the uphill side *immediately!*

OPERATION

TURNING AROUND ON A HILL (K-TURN)

If the Quadricycle stalls while climbing a hill, never back it down the hill!
Use the K-Turn to turn around.

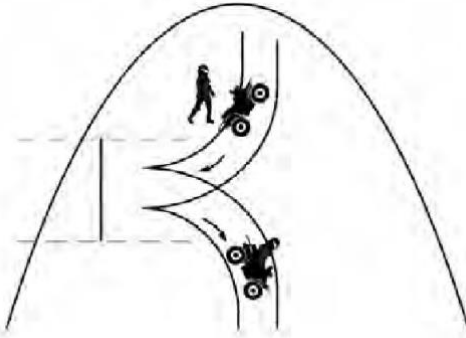

1. Stop the Quadricycle. Keep your weight uphill.
2. Always engage ADC mode (if equipped) before ascending or descending a hill. If ADC mode is not equipped, apply AWD mode before ascending or descending a hill.
3. Lock the hydraulic parking brake.
4. Leave the transmission in forward gear. Turn the engine off.
5. Stay uphill of the Quadricycle and turn the handlebars full left.
6. Squeeze the brake lever to release the parking brake.
7. Slowly release the brake lever and allow the Quadricycle to roll around to your right until it's pointing across the hill or slightly downward.
8. Lock the hydraulic parking brake.
9. Remount from the uphill side. Keep your weight uphill. *A passenger should not remount until the Quadricycle returns to firm, level ground.*
10. Apply the foot brake.
11. With the transmission still in forward, start the engine.
12. Squeeze and release the brake lever to release the parking brake.
13. Release the foot brake and drive *slowly* downhill. Control speed with either the hand or foot brake until the Quadricycle is on level ground.

DRIVING THROUGH WATER

NOTICE

Major engine damage can result if the Quadricycle is not thoroughly inspected after operation in water. Perform the services outlined in the Periodic Maintenance Chart. The following areas need special attention: engine oil, transmission oil, demand drive fluid and all grease fittings.

If the Quadricycle tips or overturns in water, or if the engine stops during or after operating in water, service is required before starting the engine. Your EGIMOTORS dealer can provide this service. If it's impossible to bring the Quadricycle in before starting the engine, perform the service outlined in the Quadricycle Immersion section of this manual, and take the Quadricycle in for service at the first opportunity.

Your QUADRICYCLE can operate through water with a maximum recommended depth equal to the bottom of the footrests.

Follow these procedures when operating through water:

1. Determine water depths and current before entering water.
2. Choose a crossing where both banks have gradual inclines.
3. Avoid operating through deep or fast-flowing water.



4. After leaving water, test the brakes. Apply them lightly several times while driving slowly. The friction will help dry out the pads.

If it's unavoidable to enter water deeper than the footrest level:

- Proceed slowly. Avoid rocks and obstacles.
- Balance your weight carefully. Avoid sudden movements.
- Maintain a steady rate of speed. Do not make sudden turns or stops. Do not make sudden throttle changes.

DRIVING OVER OBSTACLES



Follow these precautions when operating over obstacles:

1. Always check for obstacles before operating in a new area.
2. Look ahead and learn to read the terrain. Be constantly alert for hazards such as logs, rocks and low hanging branches.
3. Travel slowly and use extra caution when operating on unfamiliar terrain. Not all obstacles are immediately visible.
4. Never attempt to operate over large obstacles, such as rocks or fallen trees.
5. Always have a passenger dismount before operating over an obstacle that could cause a fall from the vehicle or Quadricycle tipover.

DRIVING IN REVERSE



Follow these precautions when operating in reverse:

1. Always check for obstacles or people behind the Quadricycle.
2. Always avoid backing downhill.
3. Back slowly.
4. Apply the brakes *lightly* for stopping.
5. Avoid turning at sharp angles.
6. Never open the throttle suddenly.
7. Do not use the override switch unless additional wheel speed is required for Quadricycle movement. Use the override with caution as rearward Quadricycle speed is greatly increased. Do not operate at wide open throttle. Operate the throttle just enough to maintain a desired speed.

NOTICE

Excessive throttle operation while in the speed limit mode may cause fuel to build in the exhaust, resulting in engine popping and/or engine damage.

OPERATION

OPERATING IN LIGHTNING

Avoid operating this Quadricycle when lightning could occur unless the Quadricycle is equipped with a fully enclosed cab. Rubber tires, rubber handgrips and a foam seat will not protect a rider from lightning strikes. Always seek safe shelter when lightning is imminent.

STARTING THE ENGINE

NOTICE

If the PIN security code feature on your Quadricycle is set to ON, the engine will not start unless the correct PIN number is entered.

1. Position the Quadricycle on a level surface outdoors or in a well-ventilated area.
2. Place the transmission in PARK.
3. Lock the brake holding latch.
4. Sit on the Quadricycle and move the engine stop switch to RUN.

NOTICE

Do not press the throttle while starting the engine.

5. Turn the ignition key past the ON position to engage the starter. Activate the starter for a maximum of five seconds, releasing the key when the engine starts.
6. If the engine does not start, return the key to the OFF position and wait five seconds before attempting to start again. Activate the starter for another five seconds if necessary. Repeat this procedure until the engine starts.

NOTICE

Immediately after starting the engine, allow the Quadricycle to warm up by avoiding heavy engine loads and high RPM. Operating the Quadricycle with heavy engine loads before the engine has warmed up may cause engine

COLD WEATHER OPERATION

If the Quadricycle is used year-round, check the oil level frequently. A rising oil level could indicate the accumulation of contaminants such as water or excess fuel in the bottom of the crankcase. Water in the bottom of the crankcase can lead to engine damage and must be drained. Water accumulation increases as outside temperature decreases.

PARKING THE QUADRICYCLE

1. Stop the Quadricycle on a level surface. When parking inside a garage or other structure, be sure that the structure is well ventilated and that the Quadricycle is not close to any source of flame or sparks, including any appliance with pilot lights.
2. Place the transmission in PARK.
3. Turn the engine off.
4. Engage the parking brake holding latch located on the left hand control.
5. Make sure the transmission is in PARK before exiting the Quadricycle.
6. Remove the ignition key to prevent unauthorized use.

PARKING ON AN INCLINE

Avoid parking on an incline if possible. If it's unavoidable, follow these precautions:

1. Stop the engine.
2. Place the transmission in PARK.
3. Engage the parking braking holding latch on left hand control.
4. Always block the rear wheels on the downhill side.

HAULING CARGO



Overloading the Quadricycle or carrying or towing cargo improperly can alter Quadricycle handling and may cause loss of control or brake instability, which can result in serious injury or death.

Always follow these precautions when hauling cargo:

REDUCE SPEED AND ALLOW GREATER DISTANCES FOR BRAKING WHEN HAULING CARGO.

NEVER EXCEED THE MAXIMUM WEIGHT CAPACITY of the Quadricycle.

When determining the weight, you are adding to the Quadricycle, include the weight of the operator, accessories, loads in the rack or box and the load on the trailer tongue. The combined weight of these items must not exceed the maximum weight capacity.

CARGO WEIGHT DISTRIBUTION

should be 1/3 on the front rack and 2/3 on the rear rack. When operating over rough or hilly terrain, reduce speed and cargo to maintain stable driving conditions. Carrying loads on only one rack increases the possibility of Quadricycle overturn.

CARRY LOADS AS LOW ON THE RACKS AS POSSIBLE.

Carrying loads high on the racks raises the center of gravity of the Quadricycle and creates a less stable operating condition.

SECURE ALL LOADS BEFORE OPERATING.

Unsecured loads can create unstable operating conditions, which could result in loss of control of the Quadricycle.

OPERATE ONLY WITH STABLE AND SAFELY ARRANGED LOADS.

When handling off-centered loads that cannot be centered, securely fasten the load and operate with extra caution.

Always attach the tow load to the hitch point designated for your Quadricycle.

HEAVY LOADS CAN CAUSE BRAKING AND CONTROL PROBLEMS.

Use extreme caution when applying brakes with a loaded Quadricycle.

Avoid terrain or situations that may require backing downhill.

USE EXTREME CAUTION

when operating with loads that extend over the rack sides. Stability and maneuverability may be adversely affected, causing the Quadricycle to overturn.

DO NOT BLOCK THE FRONT STEERING

when carrying loads on the front rack.

DO NOT TRAVEL FASTER THAN THE RECOMMENDED SPEEDS.

The Quadricycle should never exceed 10 mph (16 kph) while towing a load on a level surface. Quadricycle speed should never exceed 5 mph (8 kph) when towing loads in rough terrain, while cornering, or while ascending or descending a hill.

HAULING CARGO GUIDELINES

1. Never exceed the weight capacities specified for your QUADRICYCLE on warning labels and weight to respect are in the specifications section of this manual.
2. Cargo weight should be evenly distributed (1/3 on the front rack and 2/3 on the rear rack) and mounted as low as possible.
3. When operating over rough or hilly terrain, reduce Speed and cargo weight to maintain stable driving conditions.
4. NEVER exceed 50 km/h when rear cargo loads are above 50kg and/or front cargo loads are above 20 kg.
5. Do not fix the cargo on the steering post.
6. Slow down and be careful all the time you haul something.
7. Use low forward gear when hauling or towing heavy cargo to extend belt life.
8. Always operate the Quadricycle with extreme caution whenever hauling or towing loads. Balance, handling and control may be affected.

TOWING LOADS

Always attach a towed load to the hitch point. Remove the hitch from the QUADRICYCLE when not towing a trailer. If towing a load, reduce rear rack cargo weight by the amount of tongue weight.

- The combination of rear rack cargo weight and tongue weight must not exceed the rear rack capacity.
- The total load (operator, accessories, cargo and weight on hitch) must not exceed the maximum weight capacity of the Quadricycle.

NOTICE

Using an improper procedure or exceeding the maximum tongue weight capacity can result in serious damage to the Quadricycle and will void your warranty. Always install EGIMOTORS -approved accessories designed for QUADRICYCLE use.

WINCH GUIDE

WINCH SAFETY

These safety warnings and instructions apply if your Quadricycle came equipped with a winch or if you choose to add an accessory winch to your Quadricycle.

 **WARNING**

Improper winch use can result in SEVERE INJURY or DEATH. Always follow all winch instructions and warnings in this manual.

Your winch may have a cable made of either wire rope or specially designed synthetic rope. The term "winch cable" will be used for unless noted otherwise.

WINCH SAFETY PRECAUTIONS

1. Read all sections of this manual.
2. Never use alcohol or drugs before or while operating the winch.
3. Never allow children under 16 years of age to operate the winch.
4. Always wear eye protection and heavy gloves when operating the winch.
5. Always keep body, hair, clothing and jewelry clear of the winch cable, fairlead and hook when operating winch.
6. Never attempt to "jerk" a load attached to the winch with a moving Quadricycle. See the *Shock Loading* section on page 95.
7. Always keep the area around the Quadricycle, winch, winch cable, and load clear of people (especially children) and distractions while operating the winch.
8. Always turn the Quadricycle ignition power OFF when it and the winch are not being used.
9. Always be sure that at least five (5) full turns of winch cable are wrapped around the winch drum at all times. The friction provided by this wrapped cable allows the drum to pull on the winch cable and move the load.
10. Always apply your Quadricycle's park brake and/or park mechanism to hold the Quadricycle in place during winching. Use wheel chocks if needed.
11. Always align the Quadricycle and winch with the load directly in front of the Quadricycle as much as possible. Avoid winching with the winch cable at an angle to the winching Quadricycle's centerline whenever possible.

WINCH GUIDE

12. If winching at an angle is unavoidable, follow these precautions:
 - a. Look at the winch drum occasionally. Never let the winch cable “stack” or accumulate at one end of the winch drum. Too much winch cable at one end of the winch drum can damage the winch and the winch cable.
 - b. If stacking occurs, stop winching. Follow step 15 of Winch Operation to feed and rewind the cable evenly before continuing the winch operation.
13. Never winch up or down at sharp angles. This can destabilize the winching Quadricycle and possibly cause it to move without warning.
14. Never attempt to winch loads that weigh more than the winch’s rated capacity.
15. The winch motor may become hot during winch use. If you winch for more than 45 seconds, or if the winch stalls during operation, stop winching and permit the winch to cool down for 10 minutes before using it again.
16. Never touch, push, pull or straddle the winch cable while winching a load.
17. Never let the winch cable run through your hands, even if wearing heavy gloves.
18. Never release the clutch on the winch when the winch cable is under load.
19. Never use the winch for lifting or transporting people.
20. Never use the winch to hoist or suspend a vertical load.
21. Always inspect your winch and winch cable before each use.
22. Never winch the hook fully into the winch. This can cause damage to winch components.
23. Unplug the remote control from the Quadricycle when the winch is not in use to prevent inadvertent activation and use by unauthorized persons.
24. Never grease or oil the winch cable. This will cause the winch cable to collect debris that will shorten the life of the cable.



WINCH OPERATION

Read the Winch Safety Precautions in the preceding pages before using your winch.

TIP

Consider practicing the operation and use of your winch before you actually need to use it in the field.

⚠ WARNING

Improper winch use can result in **SEVERE INJURY** or **DEATH**. Always follow all winch instructions and warnings in this manual.

Each winching situation is unique.

- Take your time to think through the winching you are about to do.
 - Proceed slowly and deliberately.
 - Never hurry or rush during winching.
 - Always pay attention to your surroundings.
 - You may need to change your winching strategy if it is not working.
 - Always remember that your winch is very powerful.
 - There are simply some situations that you and your winch will not be able to deal with. Do not be afraid to ask others to help when this happens.
1. Always inspect the Quadricycle, winch, winch cable and winch controls for any signs of damage or parts in need of repair or replacement before each use. *Pay particular attention to the first 3 feet (1 meter) of winch cable if the winch is being used (or has been used) for lifting an accessory plow assembly.* Promptly replace any worn or damaged cable.
 2. Never operate a winch or a Quadricycle in need of repair or service.
 3. Always apply your Quadricycle's park brake and/ or park mechanism to hold the Quadricycle in place during winching. Use wheel chocks if needed.
 4. Always use the hook strap when handling the hook.



WINCH GUIDE

WARNING

Never put your fingers into the hook. This could lead to SEVERE INJURY.

- Attach the hook itself onto the load or use a tow strap or chain to secure the load to the winch cable.



TIP

A “tow strap” is NOT intended to stretch. A “recovery strap” is designed to stretch.

WARNING

Never use a recovery strap when winching due to the excessive energy that can be released if the winch cable breaks. This can result in SEVERE INJURY or DEATH. See the *Shock Loading* section on page 95.

- Never hook the winch cable back onto itself. This will damage the winch cable and may result in winch cable failure.

WARNING

Replace the winch cable at the first sign of damage to prevent SEVERE INJURY or DEATH in the event of failure. For your safety, always replace EGIMOTORS winch parts (including the cable) with genuine EGIMOTORS replacement parts available at your authorized EGIMOTORS dealer, or other qualified dealer.

- If possible, keep the winch cable aligned with the centerline of the winching Quadricycle. This will help the spooling of the winch cable and reduce the load on the fairlead.
- If freeing a stuck Quadricycle by attaching to a tree, use an item such as a tow strap to avoid damaging the tree during winch operation. Sharp cables and chains can damage and even kill trees. Please remember to Tread LightlySM (treadlightly.org).
- Before operating the winch, be sure that the safety latch on the winch cable hook is fully seated when the load is attached.
- Never operate your winch with a damaged hook or latch. Always replace damaged parts before using the winch.

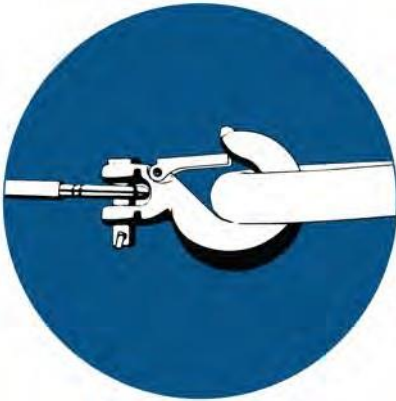

5. Never remove the hook strap from the hook.
6. Release the winch clutch and pull out the winch cable.
7. Pulling out as much cable as possible maximizes the winch's pulling capacity. Always be sure that at least five (5) full turns of winch cable are wrapped around the winch drum at all times. The friction provided by this wrapped cable allows the drum to pull on the winch cable and move the load.
8. Read and adhere to the following information for winch damping to ensure safe winch use.
 - a. In order to absorb energy that could be released by a winch cable failure, always place a "damper" on the winch cable. A damper can be heavy jacket, tarp, or other soft, dense object. A damper can absorb much of the energy released if a winch cable breaks when winching. Even a tree limb can help as a damper if no other items are available to you.
 - b. Lay the damper on top of the mid-point of the winch cable length that is spooled out.

WINCH GUIDE

- c. On a long pull, it may be necessary to stop winching so that the damper can be repositioned to the new mid-point of the winch cable. Always release the tension on the winch cable before repositioning the damper.
 - d. Avoid being directly in line with the winch cable whenever possible. Also, never permit others to stand near or in line with the winch cable during winch operation.
9. Never hook the winch cable back onto itself. This will damage the winch cable and may result in winch cable failure.
10. Never use straps, chains or other rigging items that are damaged or worn.
11. The ONLY time a winch-equipped Quadricycle should be moving when using the winch is when that Quadricycle itself is stuck. The winch equipped Quadricycle should NEVER be in motion to “shock” load the winch cable in an attempt to move a second stuck Quadricycle. See the Shock Loading section on page 95. For your safety, always follow these guidelines when winching a Quadricycle free:
- a. Release the winch clutch and spool out the necessary length of winch cable.
 - b. Align the winch cable as close as possible to the winching Quadricycle’s centerline.
 - c. Attach the winch cable hook to the anchor point or the stuck Quadricycle’s frame following instructions in this manual.
 - d. Re-engage the clutch on the winch.
 - e. Slowly winch in the slack in the winch cable.
 - f. Select the proper Quadricycle gear to propel the stuck Quadricycle in the direction of winching.
 - g. Shift to the lowest gear available on the stuck Quadricycle.
 - h. Slowly and carefully apply Quadricycle throttle and winch together to free the Quadricycle.
 - i. Stop winching as soon as the stuck Quadricycle is able to propel itself without the help of the winch.
 - j. Detach the winch cable hook.
 - k. Rewind the winch cable evenly back onto the winch drum following the instructions in this manual.
12. Never attempt to winch another stuck Quadricycle by attaching the winch cable to a suspension component, brush guard, bumper or cargo rack. Quadricycle damage may result. Instead, attach the winch to a strong portion of the Quadricycle frame or hitch.

13. Extensive winching will run down the battery on the winching Quadricycle. Let the winching Quadricycle's engine run while operating the winch to prevent the battery from running low if winching for long periods.
14. The winch motor may become hot during winch use. If you winch for more than 45 seconds, or if the winch stalls during operation, stop winching and permit the winch to cool down for 10 minutes before using it again.
15. After winching is complete, especially if winching at an angle, it may be necessary to re-distribute the winch cable across the winch drum. You will need an assistant to perform this task.
 - a. Release the clutch on the winch.
 - b. Feed out the winch cable that is unevenly bunched up in one area.
 - c. Re-engage the winch clutch.
 - d. Have an assistant pull the winch cable tightly with about 100 lbs. (45 kg) of tension using the hook strap.
 - e. Slowly winch the cable in while your assistant moves the end of the winch cable back and forth horizontally to evenly distribute the winch cable on the drum.
 - f. Doing this reduces the chances of the winch cable "wedging" itself between lower layers of winch cable.

WINCH CABLE CARE

WARNING

Use of worn or damaged cable could lead to sudden failure and SEVERE INJURY.

For your safety, always replace EGIMOTORS winch parts (including the cable) with genuine EGIMOTORS replacement parts available at your authorized EGIMOTORS dealer, or other qualified person.

1. Always inspect your winch before each use. Inspect for worn or loose parts including mounting hardware. Never use the winch if any part needs repair or replacement.
2. Always inspect your winch cable before each use. Inspect for worn or kinked winch cable.

A kinked winch cable made of wire rope is shown at right. Even after being “straightened out,” this cable has already been permanently and severely damaged. Promptly discontinue use of a winch cable in this condition.

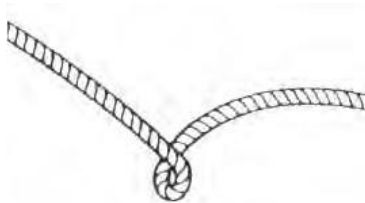

A kinked winch cable made of wire rope that has been “straightened out” is shown at right. Even though it may look usable, the cable has been permanently and severely damaged. It can no longer transmit the load that it could prior to kinking. Promptly discontinue use of a winch cable in this condition.

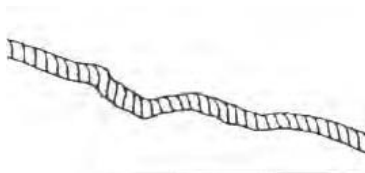

A winch cable made of synthetic rope should be inspected for signs of fraying. Replace the cable if fraying is observed (shown below). Promptly discontinue use of a winch cable in this condition. Also replace the winch cable if there are fused or melted fibers. Such an area of the synthetic rope will be stiff and appear smooth or glazed. Promptly discontinue use of a winch cable in this condition.



SHOCK LOADING

 **WARNING**

Your winch cable is very strong but it is NOT designed for dynamic, or “shock” loading. Shock loading may tension a winch cable beyond its strength and cause the cable to break. The end of a broken winch cable under such high loading can cause SEVERE INJURY or DEATH to you and other bystanders.

Winch cables are designed to NOT absorb energy. This is true of both wire-rope and synthetic-rope winch cables.

1. Never attempt to “jerk” a load with the winch. For example, never take up slack in the winch cable by moving the winching Quadricycle in an attempt to move an object. This is a dangerous practice. It generates high winch cable loads that may exceed the strength of the cable. Even a slowly moving Quadricycle can create large shock loads in a winch cable.

 **WARNING**

SEVERE INJURY or DEATH can result from a broken winch cable.

2. Never quickly turn the winch ON and OFF repeatedly (“jogging”). This puts extra load on the winch, winch cable, and generates excessive heat from the motor. This is a form of shock loading.
3. Never tow a Quadricycle or other object with your winch. Towing an object with a winch produces shock loading of the cable even when towing at slow speeds. Towing from a winch also positions the towing force high on the Quadricycle. This can cause instability of the Quadricycle and possibly lead to an accident.
4. Never use recovery straps with your winch. Recovery straps are designed to stretch and can store energy. This stored energy in the recovery strap is released if a winch cable fails making the event even more hazardous. Similarly, never use elastic “bungee” cords for winching.
5. Never use the winch to tie down a Quadricycle to a trailer or other transportation Quadricycle. This type of use also causes shock loading that can cause damage to the winch, winch cable, or Quadricycles used.

Your winch cable is designed and tested to withstand the loads produced by the winch motor when operated from a stationary Quadricycle. Always remember that the winch and winch cable are NOT designed for shock loading.

WINCH MAINTENANCE AND SERVICE SAFETY

WARNING

Improper or lack of winch maintenance and service could lead to SEVERE INJURY or DEATH. Always follow all winch instructions and warnings in this manual.

1. Always inspect your winch before each use. Inspect for worn or kinked winch cable. Also inspect for worn or loose parts including mounting hardware.
2. Permit your winch motor to cool down prior to servicing your winch.
3. Never work on your winch without first disconnecting the battery connections to prevent accidental activation of the winch.
4. For your safety, always replace EGIMOTORS winch parts (including the cable) with genuine EGIMOTORS replacement parts available at your authorized EGIMOTORS dealer, or other qualified person.
5. Some winch models use wire rope as the winch cable. Other winches use a specially designed synthetic rope as the winch cable.
6. Never replace a synthetic-rope winch cable with a consumer-grade polymer rope such as can be purchased in a hardware store. Although they may look similar, they are NOT alike. A polymer rope not designed for winch use will stretch and store excessive energy when winching.

WARNING

Failure of a stretched rope under winching conditions will release all of the stored energy. This will increase the chances of SEVERE INJURY or DEATH.

EMISSION CONTROL SYSTEMS

NOISE EMISSION CONTROL SYSTEM

Do not modify the engine, intake or exhaust components, as doing so may affect compliance with governmental noise level requirements.

SPARK ARRESTER

Your EGIMOTORS Quadricycle has a spark arrester that was designed for on-road and off-road operation. It is required that this spark arrester remain installed and functional when the Quadricycle is operated.

CRANKCASE EMISSION CONTROL SYSTEM

This engine is equipped with a closed crankcase system. Blow-by gases are forced back to the combustion chamber by the intake system. All exhaust gases exit through the exhaust system.

EXHAUST EMISSION CONTROL SYSTEM

Exhaust emissions are controlled by engine design. An electronic fuel injection (EFI) system controls fuel delivery. The engine and EFI components are set at the factory for optimal performance and are not adjustable.

ELECTROMAGNETIC INTERFERENCE

This Quadricycle complies with the EMC requirements of UN ECE Regulation 10.

Non-ionizing Radiation: This Quadricycle emits some electromagnetic energy. People with active or non-active implantable medical devices (such as heart monitoring or controlling devices) should review the limitations of their device and the applicable electromagnetic standards and directives that apply to this Quadricycle.

EUROPEAN VIBRATION AND NOISE

The driver-perceived noise and hand/arm and whole body vibration levels of this machinery is measured per EN 15997.

MAINTENANCE

PERIODIC MAINTENANCE

Any qualified repair shop or person may maintain, replace or repair the emission control devices or systems on your Quadricycle. An authorized EGIMOTORS dealer can perform any service that may be necessary for your Quadricycle. EGIMOTORS also recommends EGIMOTORS parts for emissions-related service, however equivalent parts can be used.

It is a potential violation of the EU law if a part supplied by an aftermarket parts manufacturer reduces the effectiveness of the Quadricycle's emission controls. Tampering with emission controls is prohibited by law.

Owners are responsible for performing the scheduled maintenance identified in this owner's manual. Careful periodic maintenance will help keep your Quadricycle in safe, reliable condition. Inspect, clean, lubricate, adjust and replace parts as necessary. When inspection reveals the need for replacement parts, genuine EGIMOTORS parts are available from your EGIMOTORS dealer. Equivalent parts may be used for emissions-related service.

Record maintenance and service in the Maintenance Log beginning on page 175. Service and adjustments are important for proper Quadricycle operation. If you're not familiar with safe service and adjustment procedures, a qualified dealer can perform these operations. Maintenance intervals in the following chart are based upon average riding conditions and an average Quadricycle speed of approximately 10 miles per hour. Quadricycles subjected to severe use must be inspected and serviced more frequently.

ELEVATING THE QUADRICYCLE FOR SERVICE

Some service procedures require elevation of the Quadricycle. Always position the Quadricycle on a firm, level surface before elevating. Do not position a jack or jack stand under any components other than the frame. Use an appropriate lift or floor jack. This Quadricycle is not equipped with dedicated jacking points. Place the floor jack at the front (or rear) of the Quadricycle, directly under the center of the unit. Make sure the floor jack makes contact only with the *frame* of the Quadricycle while lifting ①. Do not allow the Quadricycle to remain elevated on a floor jack. After elevating, place jack stands under the *frame* on each side of the floor jack, then lower the floor jack.

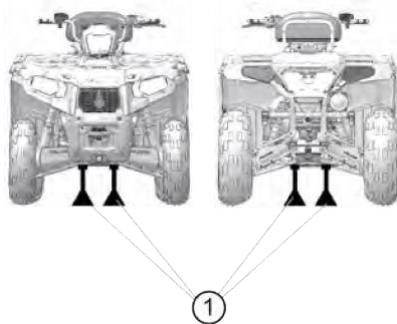

MAINTENANCE

SEVERE USE DEFINITION

- Frequent immersion in mud, water or sand
- Frequent or prolonged operation in dusty environments
- Short trip cold weather operation
- Racing or race-style high RPM use
- Prolonged low speed, heavy load operation
- Extended idle

Pay special attention to the oil level. A rise in oil level during cold weather can indicate contaminants collecting in the oil sump or crankcase. Change oil immediately if the oil level begins to rise. Monitor the oil level, and if it continues to rise, discontinue use and determine the cause. Your dealer can assist.

PERIODIC MAINTENANCE

Any qualified repair shop or person may maintain, replace or repair the emission control devices or systems on your Quadricycle. An authorized EGIMOTORS dealer can perform any service that may be necessary for your Quadricycle. EGIMOTORS also recommends EGIMOTORS parts for emissions-related service, however equivalent parts can be used.

It is a potential violation of the Clean Air Act if a part supplied by an aftermarket parts manufacturer reduces the effectiveness of the Quadricycle's emission controls. Tampering with emission controls is prohibited by federal law.

Owners are responsible for performing the scheduled maintenance identified in this owner's manual. Careful periodic maintenance will help keep your Quadricycle in safe, reliable condition. Inspect, clean, lubricate, adjust and replace parts as necessary. When inspection reveals the need for replacement parts, genuine EGIMOTORS parts are available from your EGIMOTORS dealer. Equivalent parts may be used for emissions-related service.

Record maintenance and service in the Maintenance Log beginning on page 175. Service and adjustments are important for proper Quadricycle operation. If you're not familiar with safe service and adjustment procedures, a qualified dealer can perform these operations. Maintenance intervals in the following chart are based upon average riding conditions and an average Quadricycle speed of approximately 10 miles per hour. Quadricycles subjected to severe use must be inspected and serviced more frequently.

MAINTENANCE CHART KEY

SYMBOL	DESCRIPTION
XU	Perform these procedures more often for Quadricycles subjected to severe use.
D	Have an authorized Egimotors dealer or other qualified person perform these services.

 **WARNING**

Improperly performing the procedures marked with a **D** could result in component failure and lead to serious injury or death. Have an authorized EGIMOTORS dealer or other qualified person perform these services.

Perform all services at whichever maintenance interval is reached first. Record maintenance and service in the Maintenance Log.

ITEM	MAINTENANCE INTERVAL (WHICHEVER COMES FIRST)			REMARKS	
	HOURS	CALENDAR	KM		
	Steering	–	Pre-Ride	–	See Pre-Ride Checklist section.
	Front suspension	–		–	
	Rear suspension	–		–	
	Tires	–		–	
	Brake fluid level	–		–	
	Brake lever travel	–		–	
	Brake system	–		–	
	Wheels/fasteners	–		–	
	Frame fasteners	–		–	
	Engine oil level	–		–	
	Winch	–	–	See the Winch Guide section.	
XU	Air filter, pre-filter	–	Daily	–	Inspect; clean often; replace as needed. See the Air Filter section.
	Coolant	–	Daily	–	Check level
XU	Power steering unit (if equipped)	–	Daily	–	Inspect daily; clean often
	Headlamp/taillight	–	Daily	–	Check operation
XU	Air filter, main element	–	Weekly	–	Inspect; replace as needed. See the Air Filter section.

MAINTENANCE

ITEM		MAINTENANCE INTERVAL (WHICHEVER COMES FIRST)			REMARKS
		HOURS	CALENDAR	KM	
XU	Brake pad wear	10 H	Monthly	(160)	Inspect periodically
	Battery	20 H	Monthly	(320)	Check terminals; clean; test
	Fuel system	20 H	Monthly		Inspect; cycle key to pressurize fuel pump; check lines and fittings for leaks and abrasion
XU	Engine oil change	25 H	1 M	(400)	Break-in oil and filter change (see the Engine Oil section)
XU	Demand drive fluid (extreme use)	25 H	1 M	(400)	Change fluid every 25 hours if 4WDC is subjected to extreme use. See the Front Gearcase section.
XU	Demand drive fluid	25 H	1 M	(400)	Break-in oil level check
XU	Rear gearcase oil	25 H	1 M	(400)	Break-in oil level check
XU	Transmission oil	25 H	1 M	(400)	Break-in oil level check
XU	General lubrication	50 H	3 M	(800)	Lubricate all fittings, pivots, cables, etc.
	Shift linkage	50 H	6 M	(800)	Inspect, lubricate
D	Steering	50 H	6 M	(800)	Lubricate
XU	Front suspension	50 H	6 M	(800)	Lubricate
XU	Rear suspension	50 H	6 M	(800)	Lubricate
	Throttle Body Intake Duct	50 H	6 M	(800)	Inspect duct for proper sealing/air leaks
	Drive belt	50 H	6 M	(800)	Inspect; replace as needed
	Cooling system	50 H	6 M	(1600)	Inspect coolant strength seasonally; pressure test system yearly
XU	Radiator	50 H	6 M	(1600)	Inspect; clean external surfaces
XU	Cooling hoses	50 H	6 M	(1600)	Inspect for leaks
XU	Oil lines and fasteners	100 H	6 M	(1600)	Inspect for leaks and loose fittings
XU	Engine oil change	100 H	6 M	(1600)	Change the oil and filter
XU	Demand drive fluid (normal use)	100 H	12 M	(1600)	Change fluid
XU	Rear gearcase oil	100 H	12 M	(1600)	Change fluid

MAINTENANCE

ITEM		MAINTENANCE INTERVAL (WHICHEVER COMES FIRST)			REMARKS
		HOURS	CALENDAR	KM	
XU	Transmission oil	100 H	12 M	(1600)	Change fluid
D	Fuel system	100 H	12 M	(1600)	Cycle key to pressurize fuel pump; check for leaks at fill cap, fuel lines/rail and fuel pump; replace lines every two years
XU	Engine mounts	100 H	12 M	(1600)	Inspect
	Exhaust muffler/ pipe	100 H	12 M	(1600)	Inspect
D	Spark plug	100 H	12 M	(1600)	Inspect; replace as needed
XU	Wiring	100 H	12 M	(1600)	Inspect for wear, routing, security; apply dielectric grease to connectors subjected to water, mud, etc.
D	Clutches (drive and driven)	100 H	12 M	(1600)	Inspect; clean; replace worn parts
D	Front wheel bearings	100 H	12 M	(1600)	Inspect; replace as needed
D	Brake fluid	200 H	24 M	(3200)	Change every two years
	Spark arrester	300 H	36 M	(4800)	Clean out
XU	Coolant		60 M		Replace coolant
D	Valve clearance	1000 H		(16000)	Inspect; adjust
D	Toe adjustment				Inspect periodically; adjust when parts are replaced
	Headlight aim				Adjust as needed

MAINTENANCE

LUBRICATION GUIDE

Check and lubricate all components at the intervals outlined in the Periodic Maintenance Chart. Items not listed in the chart should be lubricated at the General Lubrication interval.

The a-arms and upper control arms are lubricated at the factory, and no additional lubrication will be needed. However, if these components are subjected to severe use, grease zerks have been provided for additional lubrication at the user's discretion.

ITEM	RECOMMENDED LUBRICANT	CAPACITY AT FLUID CHANGE	FILL PLUG TORQUE	DRAIN PLUG TORQUE	SEE PAGE
Engine Oil	PS-4 5W-50 4-Cycle Oil	(1.9 l)	—	(16 Nm)	page 105
Transmission Oil	AGL Gearcase Lubricant & Transmission Fluid	(1100 ml)	(14-19 Nm)	(14-19 Nm)	page 110
Demand Drive Fluid (Front Gearcase)	Demand Drive Fluid	(275 ml)	(11-14 Nm)	(15 Nm)	page 111
Rear Gearcase Oil	Angle Drive Fluid (or GL5 80-90 weight gear lube)	(210 ml)	(14-19 Nm)	(14-19 Nm)	page 113
Brake Fluid	DOT 4 Brake Fluid	—	—	—	page 118
Front Prop Shaft Yoke	U-Joint Grease	Grease fittings (3 pumps maximum) every 500 miles, before long periods of storage, or after pressure washing or submerging.			
A-Arms, Front and Rear	All-Season Grease	Grease fittings after extreme use or if suspension becomes squeaky.			

ENGINE OIL

Always check and change the oil at the intervals outlined in the Periodic Maintenance Chart. Always use the recommended engine oil. Always change the oil filter whenever changing oil.

Pay special attention to the oil level. A rise in oil level during cold weather can indicate contaminants collecting in the oil sump or crankcase. Change oil immediately if the oil level begins to rise. Monitor the oil level, and if it continues to rise, discontinue use and determine the cause. Your dealer can assist.

WARNING

Quadricycle operation with insufficient, deteriorated, or contaminated engine oil will cause accelerated wear and may result in engine seizure, accident and injury.

Always perform the maintenance procedures as outlined in the Periodic

OIL RECOMMENDATIONS

Always change the oil filter whenever changing oil.

EGIMOTORS recommends the use of POLARIS PS-4 Full Synthetic 5W-50 4-cycle oil or a similar oil for this engine. Oil may need to be changed more frequently if POLARIS oil is not used. Always use 5W-50 oil. Follow the manufacturer's recommendations for ambient temperature operation.

See the Lubrication Guide section for fluid recommendations, capacities and plug torques.

NOTICE

Mixing brands or using a non-recommended oil may cause serious engine damage. Always use the recommended oil. Never substitute or mix oil brands.

MAINTENANCE

OIL LEVEL

Check the oil level when the engine is cold. *Never check the oil with the engine running.*

Access the oil dipstick and fill tube from the left side of the Quadricycle.



1. Position the Quadricycle on a level surface. Place the transmission in PARK.
2. Remove the dipstick. Wipe it dry with a clean cloth.
3. Reinstall and tighten the dipstick.
4. Remove the dipstick and check the oil level.

5. Add the recommended fluid as needed. Maintain the oil level in the safe range between the FULL and ADD marks. Do not overfill.

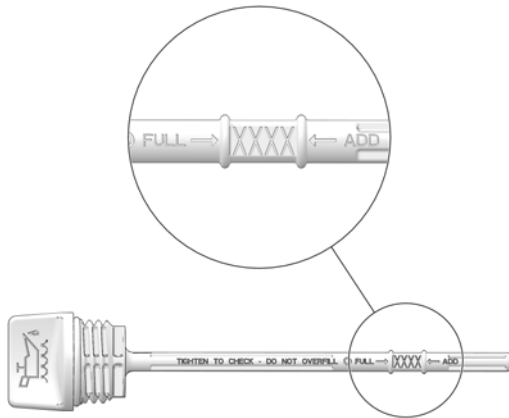

6. Reinstall and tighten the dipstick.

ENGINE OIL AND FILTER CHANGE

The engine oil and filter should be changed in accordance with the Egimotors Maintenance Schedule. Always change the oil filter when you change the engine oil.

NOTICE

Be prepared to collect the fluid with a container before you open any compartment or disassemble any component that contains fluid.

1. Position the Quadricycle on a level surface.
2. Put the transmission in PARK (P).
3. Start the engine. Allow it to idle for two or three minutes. Then stop the engine.

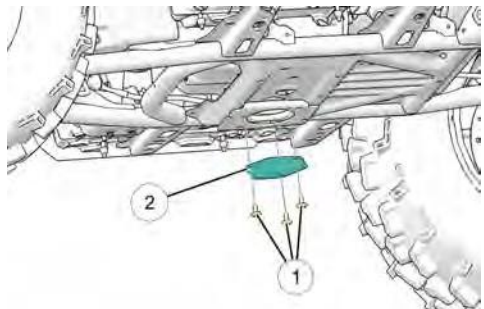

MAINTENANCE

- Remove the T40 Torx-headed screws ① and oil filter plate ② from the frame.
- Clean the area around the drain plug ③.
- Put an oil drain pan below the engine crankcase.

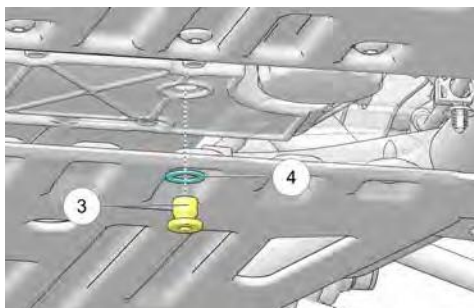

- Using a 6 mm Hex driver, remove the drain plug and sealing washer ④. Allow the engine oil to drain completely.

⚠ CAUTION

Hot oil can cause burns or skin damage.

- Replace the sealing washer on the drain plug.

NOTICE

The sealing surfaces on the drain plug and crankcase should be clean and free of burrs, nicks, or scratches.

- Install the drain plug and torque to specification.

TORQUE

Oil Drain Plug
(16 N·m)

- Locate the oil filter ③ through the access hole in the frame. Put an oil drain pan and shop towels below the oil filter. Use an Oil Filter Wrench (PU-50105) to turn the oil filter counter-clockwise to remove it.
- Clean the oil filter sealing surface on the engine crankcase.

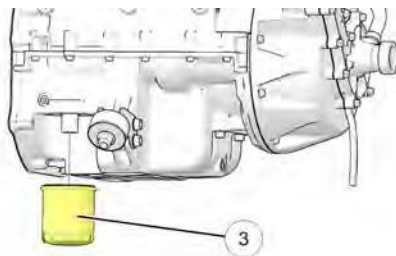

12. Make sure the O-ring on the new oil filter is in good condition. Lubricate the O-ring on the new filter with a thin layer of engine oil.
13. Install the new oil filter to specification.

TORQUE

Oil Filter

Turn by hand until filter O-ring contacts sealing surface, then turn an additional 3/4 turn.

14. Replace the oil filter plate. Torque screws to specification.

TORQUE

Oil Filter Plate Screws
(9 N-m)

15. Remove the dipstick. Add the Egimotors recommended lubricant as necessary to bring the oil level between the full and add lines on the dipstick. DO NOT overfill.

FLUID CAPACITY

Recommended Engine Oil:
POLARIS PS-4 Synthetic 4-Cycle Engine Oil
Capacity:
(1.9 LITER)

16. Install the dipstick.
17. Start the engine. Allow it to idle for one to two minutes.
18. Stop the engine and check for leaks.
19. Check the engine oil level. Add engine oil as needed.
20. Dispose the used oil and filter properly.

MAINTENANCE

TRANSMISSION OIL

Always check and change the transmission oil at the intervals outlined in the Periodic Maintenance Chart. See the Lubrication Guide section for fluid recommendations, capacities, and plug torques. Maintain the oil level at the bottom of the fill plug hole ②.



The fill plug is located on the right side of the QUADRICYCLE behind the footwell. The drain plug ① is located on the bottom rear side of the gearcase.

OIL CHECK

1. Remove the fill plug. Check the oil level.
2. Add the recommended fluid as needed to bring the level to the bottom of the fill hole threads.
3. Reinstall the fill plug. Torque to specification.

TORQUE

Fill Plug (19 N·m)

4. Reinstall the footwell.

OIL CHANGE

1. Place a drain pan under the gearcase. Remove the drain plug. Allow the oil to drain completely.
2. Clean and reinstall the drain plug. Torque to specification.

TORQUE

Drain Plug (16 N·m)

3. Remove the fill plug. Add the proper amount of the recommended oil.

4. Reinstall the fill plug. Torque to specification.

TORQUE

Fill Plug (16 N·m)

5. Check for leaks.
6. Reinstall the footwell.
7. Dispose of used oil properly.

FRONT GEARCASE (DEMAND DRIVE) FLUID

Always check and change the demand drive fluid at the intervals outlined in the Periodic Maintenance Chart.

Change the front gearcase fluid every 25 hours if the ADC unit is exposed to extreme use. Extreme use includes any of the following:

- Operation in ADC mode for prolonged periods.
- Constant ADC operation on hilly or mountainous terrain.
- ADC is the primary mode of all-wheel-drive operation.

TIP

If the front gearcase is making excessive noise during ADC operation, change the demand drive fluid. If the noise continues, please see your EGIMOTORS dealer or other qualified service facility for service.
--

Use the recommended fluid. Use of other fluids may result in improper operation of components. Maintain the fluid level at the bottom of the fill hole threads. The fill plug is located on the right side of the demand drive unit. The drain plug is located on the bottom right side of the unit.

MAINTENANCE

FLUID CHECK

1. Position the Quadricycle on a level surface. Remove the fill plug ①. Check the fluid level.
2. Add the recommended fluid as needed to bring the level to the bottom of the fill hole threads.
3. Reinstall the fill plug. Torque to specification.

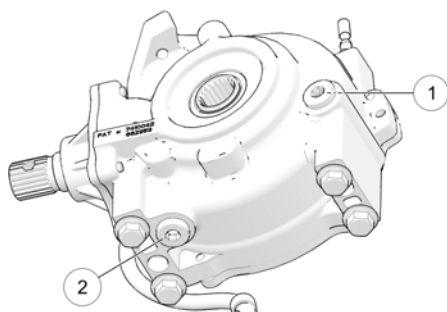

TORQUE

Fill Plug (26 N·m)

FLUID CHANGE

1. Position the Quadricycle on a level surface. Remove the drain plug ①.
2. Place a drain pan under the demand drive unit. Remove the drain plug ②. Allow the fluid to drain completely.
3. Clean and reinstall the drain plug. Torque to specification.

TORQUE

Drain Plug (26 N·m)

4. Add the proper amount of the recommended fluid.
5. Reinstall the fill plug. Torque to specification.

TORQUE

Fill Plug (26 N·m)

6. Check for leaks. Dispose of used fluid properly.

FLUID CHECK

1. Position the Quadricycle on a level surface. Remove the fill plug. Check the fluid level.
2. Add the recommended fluid as needed to bring the level to the bottom of the fill hole threads.
3. Reinstall the fill plug. Torque to specification.

FLUID CHANGE

1. Position the Quadricycle on a level surface. Remove the fill plug.
2. Place a drain pan under the demand drive unit. Remove the drain plug. Allow the fluid to drain completely.
3. Clean and reinstall the drain plug. Torque to specification.
4. Add the proper amount of the recommended fluid.
5. Reinstall the fill plug. Torque to specification.
6. Check for leaks. Dispose of used fluid properly.

REAR GEARCASE OIL

Always check and change the rear gearcase oil at the intervals outlined in the Periodic Maintenance Chart.

The fill plug is located on the rear of the gearcase. The drain plug is located on the bottom of the gearcase.

Maintain the fluid level at the bottom of the fill hole threads. Do not overfill.

OIL CHECK

1. Position the Quadricycle on a level surface.
2. Remove the fill plug
①. Check the oil level.
3. Add the recommended oil as needed to bring the level to the bottom of the fill hole threads. *Do not overfill.*
4. Reinstall the fill plug. Torque to specification.

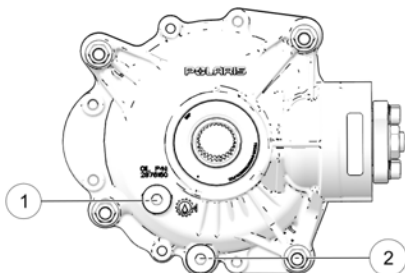

MAINTENANCE

TORQUE

Fill Plug
(16 N·m)

OIL CHANGE

1. Position the Quadricycle on a level surface.
2. Place a drain pan under the drain holew.
3. Remove the drain plug. Allow the oil to drain completely.
4. Clean and reinstall the drain plug with a new sealing washer. Torque to specification.

TORQUE

Drain Plug
(16 N·m)

5. Remove the fill plug. Add the proper amount of the recommended oil. *Do not overfill.*
6. Reinstall the fill plug. Torque to specification.

TORQUE

Fill Plug
(16 N·m)

7. Check for leaks.
8. Dispose of used oil properly.

POWER STEERING UNIT (IF EQUIPPED)

If your model is equipped with power steering, frequently clean the areas around and on the power steering unit to allow proper cooling. Clean these areas ③ thoroughly.

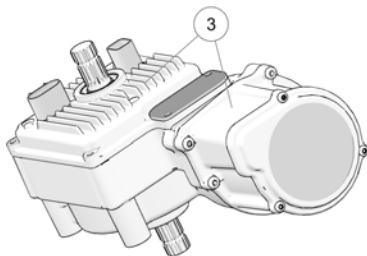

COOLING SYSTEM

The engine coolant level is controlled, or maintained, by the recovery system. The recovery system components are the recovery bottle, the radiator filler neck, the radiator pressure cap and the connecting hose.

As coolant operating temperature increases, the expanding (heated) excess coolant is forced out of the engine, past the pressure cap, and into the recovery bottle. As engine coolant temperature decreases the contracting (cooled) coolant is drawn back up from the bottle, past the pressure cap, and into the radiator.

Some coolant level drop on new Quadricycles is normal as the system is purging itself of trapped air. Check the coolant level and maintain as recommended by adding coolant to the recovery bottle.

EGIMOTORS recommends the use of EGIMOTORS Antifreeze 50/50 Premix. This antifreeze is already premixed and ready to use. Do not dilute with water. See the Egimotors Products section for the part numbers.

RECOVERY COOLANT BOTTLE

The recovery bottle fluid level can be viewed from inside the front right wheel well. Access the recovery bottle cap under the front storage compartment.

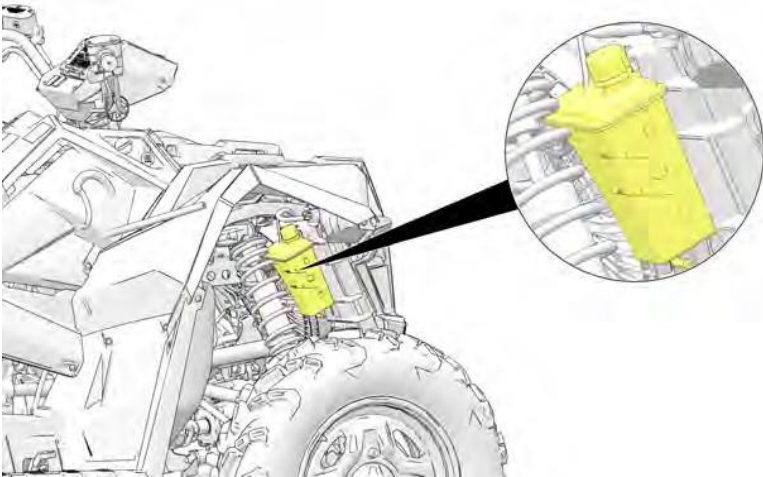

MAINTENANCE

1. View the fluid level in the bottle.
2. If the level is low, remove the front rack.
3. Remove the bottle cap and add coolant as needed. Maintain the coolant level between the minimum ① and maximum ② marks on the bottle (when the fluid is cool).

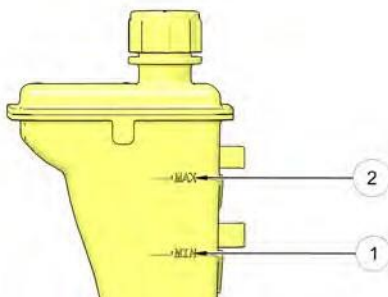

4. Reinstall the cap.
5. Reinstall the front rack.

SPORTSMAN

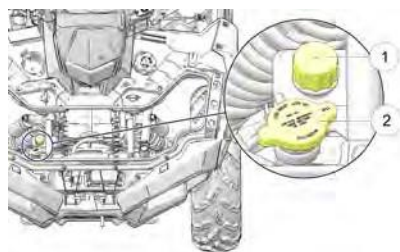

- ① Recovery Bottle Cap
- ② Radiator Cap

SCRAMBLER

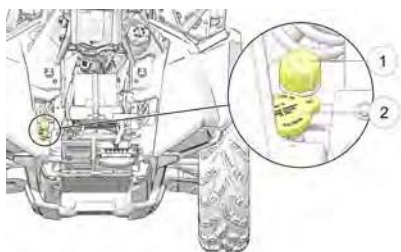

- ① Recovery Bottle Cap
- ② Radiator Cap

RECOVERY BOTTLE COOLANT

The recovery bottle fluid level can be viewed from inside the front right wheel well. Access the recovery bottle cap under the front box.

1. View the fluid level in the bottle.
2. If the level is low, remove the bottle cap and add coolant as needed. Maintain the coolant level between the minimum and maximum marks on the bottle (when the fluid is cool).
3. Reinstall the cap.
4. Close and secure the front box and cover.

RADIATOR COOLANT

To ensure that the coolant maintains its ability to protect the engine, we recommend that the system be completely drained every five (5) years and fresh Antifreeze 50/50 Premix added.

Any time the cooling system has been drained for maintenance or repair, replace the coolant with fresh Antifreeze 50/50 Premix. If the recovery bottle has run dry, check the level in the radiator. Add coolant as needed.

 **CAUTION**

Escaping steam can cause burns. Never remove the pressure cap while the engine is warm or hot. Always allow the engine to cool before removing the pressure cap.

1. Access the pressure cap under the front box. See the Front Compartment section for details.
2. Remove the pressure cap.
3. Using a funnel, slowly add coolant through the radiator filler neck.
4. Reinstall the pressure cap. Use of a non-standard pressure cap will not allow the recovery system to function properly. Your EGIMOTORS dealer can provide the correct replacement part.
5. Close and secure the front box and cover.

MAINTENANCE

BRAKES

BRAKE FLUID

Check brake fluid levels for both brake systems before each ride. Always maintain brake fluid at the recommended level. Do not overfill.

The brakes should feel firm when they're applied. Spongy or weak brakes may indicate a fluid leak or low fluid level. A low fluid level may also mean that brake pads are worn and need to be replaced. Do not operate the Quadricycle with spongy or weak brakes. See your dealer for service.

CAUTION

Operating the Quadricycle with a spongy brake can result in loss of braking, which could cause an accident. Never operate the Quadricycle with spongy-feeling brakes.

If the fluid level is low add DOT 4 brake fluid only. See the Egimotors Products section for part numbers.

WARNING

An over-full master cylinder may cause brake drag or brake lock-up, which could result in serious injury or death. Maintain brake fluid at the recommended level. Do not overfill.

Under normal operation, the diaphragm extends into the reservoir as fluid level drops. If the fluid level is low and the diaphragm is not extended, a leak is likely and the diaphragm should be replaced. To ensure proper diaphragm operation, always fill the reservoir as needed whenever the cover is loosened or removed. Do not overfill.

WARNING

Never store or use a partial bottle of brake fluid. Brake fluid is hygroscopic, meaning it rapidly absorbs moisture from the air. The moisture causes the boiling temperature of the brake fluid to drop, which can lead to early brake fade and the possibility of accident or severe injury. After opening a bottle of brake fluid, always discard any unused portion.

HAND BRAKE

The master cylinder ① is located on the left handlebar. Maintain the fluid level 6 mm below the top edge of the master cylinder. Do not overfill.

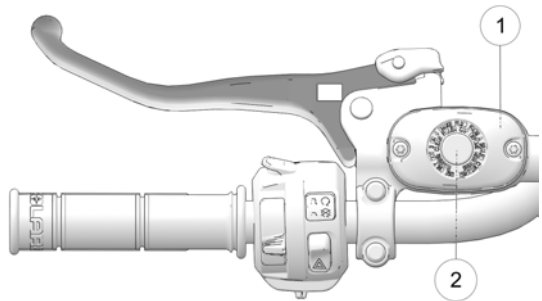

1. Position the Quadricycle on a level surface. Make sure the handlebars are straight.
2. View the fluid level through the indicator window (eye) ② on the top of the master cylinder.

NOTICE

The eye will appear dark when the fluid level is full ③. When fluid is low ④, the eye will be clear.



3. If the fluid level is low, remove the cover screws and add fluid to the fill line. *Do not overfill.*
4. Reinstall the cover. Torque screws to 0.8 Nm.

MAINTENANCE

FOOT BRAKE

The foot brake fluid reservoir ① is located under the front rack.

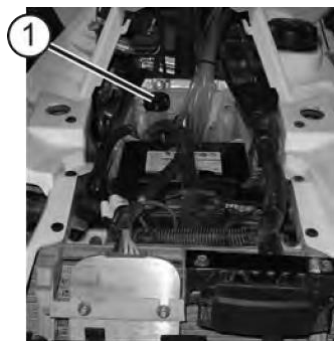

SCRAMBLER

BRAKE INSPECTION

The front and rear brakes are hydraulic disc brakes, activated by applying the foot brake. The handlebar brake is also hydraulic. Both brake systems are self-adjusting.

Perform the following checks to keep the brake systems in good operating condition. Check more often if brakes are used heavily under normal operation.

1. Always keep brake fluid at an adequate level.
2. Check the brake systems regularly for fluid leaks.
3. Check the brakes for excessive travel or spongy feel.
4. Check the friction pads for wear, damage, and looseness. Replace the pads when the friction material is worn to 0.030 (0.762 mm).

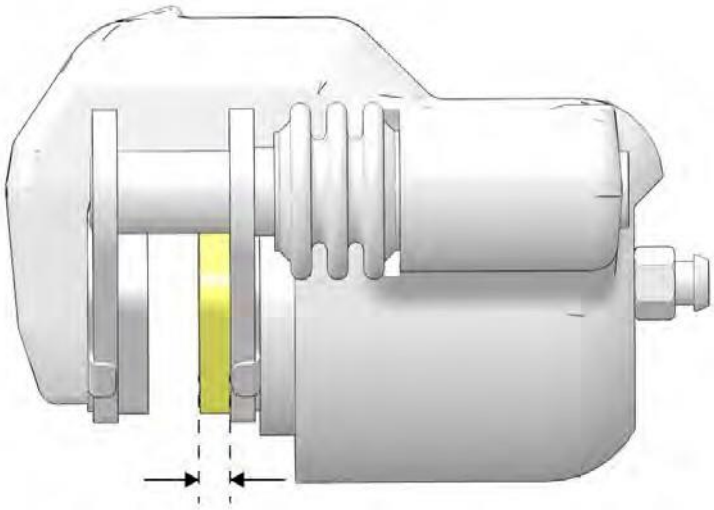

5. Check the security and surface condition of the disc. Clean any grease using a recommended brake cleaner or alcohol. Do not use spray lubricants or other petroleum-based products. If you discover any damage (cracks, excessive corrosion, warping) see your dealer for service before operating.

MAINTENANCE

HAND BRAKE

The front and rear brakes are hydraulic disc brakes, activated by moving the single brake lever toward the handlebar. These brakes are self-adjusting.

Under normal operation, the diaphragm extends into the reservoir as fluid level drops. If the fluid level is low and the diaphragm is not extended, a leak is likely and the diaphragm should be replaced. To ensure proper diaphragm operation, always fill the reservoir as needed whenever the cover is loosened or removed. Do not overfill.

WARNING

An over-full master cylinder may cause brake drag or brake lock-up, which could result in serious injury or death. Maintain brake fluid at the recommended level. Do not overfill.

The following checks are recommended to keep the brake system in good operating condition. Check more often if brakes are used heavily under normal operation.

1. Always keep brake fluid at an adequate level. See the Master Cylinder/Brake Fluid section for details.
2. Check the brake system for fluid leaks.
3. Check the brakes for excessive travel or spongy feel.
4. Check the friction pads for wear, damage and looseness. Replace brake pads when they are worn to 4.6 mm (0.180 in.).
5. Check the security and surface condition of the disc. Clean any grease using a recommended brake cleaner or alcohol. Do not use spray lubricants or other petroleum-based products. If you discover any damage (cracks, excessive corrosion, warping) see your dealer for service before operating.

AUXILIARY FOOT BRAKE

The hydraulic auxiliary brake system requires no adjustment. Check the brake fluid level frequently for the auxiliary brake system.

STEERING ASSEMBLY

The steering assembly of the QUADRICYCLE should be checked periodically for loose nuts and bolts. If loose nuts and bolts are found, see your authorized dealer or other qualified service facility before operating the Quadricycle.

SEAT REMOVAL

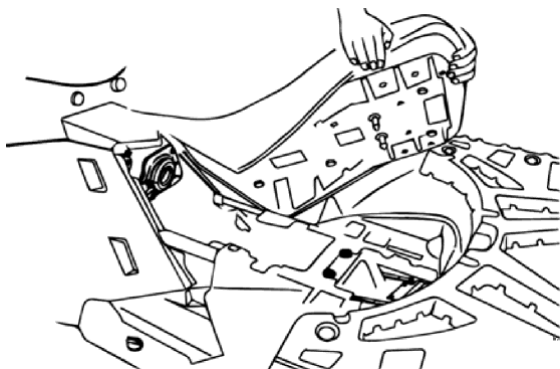

1. Locate the seat removal latch in the center of the seat's rear.
2. Pull on the latch handle to disengage the seat from the Quadricycle's frame.
3. Remove the seat.

SIDE PANEL / FOOTWELL REMOVAL

1. Remove the seat before removing a side panel.
2. To remove a side panel or footwell, remove the fasteners ① securing it to the frame. Lift the right side panel upward while removing it to clear the shifter knob.

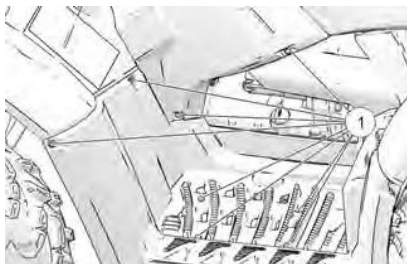

TIRES

WARNING

Operating your QUADRICYCLE with worn tires, improperly inflated tires, non-standard tires or improperly installed tires will affect Quadricycle handling and could cause an accident resulting in serious injury or death. Always follow all tire maintenance procedures as outlined in this manual and on the labels on the Quadricycle. Always use original equipment size and type when replacing tires.

Refer to the specifications section for recommended tire type, size and pressure.

TIRE AGING

WARNING

Tires age, even if they are unused or only used occasionally. Evidence of ageing may appear as cracks in the treads or sidewall rubber, sometimes accompanied by carcass deformation. Old tires should be checked by tire specialists to determine their suitability for further use.

TIRE TREAD DEPTH

Always replace tires when tread depth is worn to 3 mm (1/8") or less.

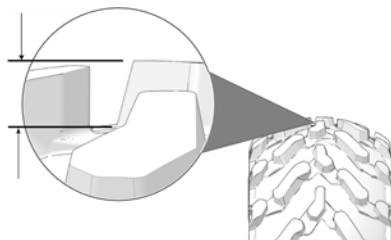

FRONT WHEEL HUB TIGHTENING

Front wheel bearing tightness and spindle nut retention are critical component operations. All service must be performed by your authorized dealer or other qualified service facility.

MAINTENANCE

WHEEL REMOVAL

1. Stop the engine.
2. Place the transmission in PARK.
3. Lock the parking brake.
4. Loosen the wheel nuts slightly.

WARNING

Do not service axle nuts that have a cotter pin installed. Your authorized dealer can assist.

5. Elevate the side of the Quadricycle by placing a suitable stand under the footrest frame.
6. Remove the wheel nuts.
7. Remove the wheel.

WHEEL INSTALLATION

1. Place the transmission in PARK.
2. Lock the parking brake.
3. Place the wheel on the hub with the valve stem toward the outside and rotation arrows on the tire pointing toward forward rotation (if equipped).
4. Install the wheel nuts and finger-tighten them.
5. Lower the Quadricycle to the ground.
6. Torque the wheel nuts to specification.

WARNING

Loose nuts could cause a tire to come off during operation, which could result in an accident or overturn. Always ensure that all nuts are torqued to specification.

WHEEL NUT TORQUE SPECIFICATIONS

Check the wheel nut torques occasionally and when they've been loosened for service.

WHEEL TYPE	NUT TORQUE
All	102 Nm

TOE ALIGNMENT

WARNING

Severe injury or death can result from improper toe alignment and adjustment. Do not attempt to adjust tie rod alignment. All tie rod adjustments should be performed by an authorized EGIMOTORS dealer or other qualified service facility.

Use the following procedure to check the toe alignment of the Quadricycle. The recommended toe alignment is (6-12 mm).

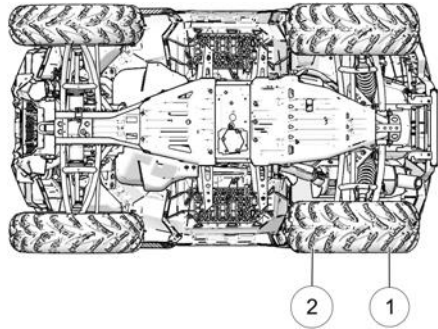

1. Position the Quadricycle on a level surface.
2. Place the handlebars in a straight-ahead position.
3. Tie a length of string between two stands. Position the stands so that the string is flush with the side of the rear tire. If available, you may use a long straight-edge instead of string.
4. Measure the distance from the string to the rim at the front ① and rear ② of the front rim. The rear measurement should (3–6 mm) more than the front measurement on each side of the Quadricycle to obtain the recommended (6–12 mm) toe out alignment.
5. Repeat the measurement procedure on the other side of the Quadricycle.
6. If you discover improper alignment, see your EGIMOTORS dealer for service.

MAINTENANCE

AIR FILTER INSTALLATION

1. Remove the seat, the air box cover strap, and remove the air box cover.
2. Remove the filter.
3. Remove the fabric type pre- filter from the main filter. Wash the pre-filter in soapy water, then rinse and let dry.
4. Reinstall the pre-filter over the main filter. Install a new main filter if needed.
5. Reinstall the filter into the air box.
6. Reinstall the air box cover and the seat.

FUSE REPLACEMENT

If the engine stops or will not start, or if you experience other electrical failures, a fuse may need replacement. Locate and correct any short circuits that may have caused the blown fuse, then replace the fuse.

Spare fuses are provided in the fuse box.

1. Access the fuses under the front box.
2. Remove the fuse box cover.
3. Remove the suspect fuse from the fuse panel. If the fuse is blown, install a new fuse with the same amperage rating.
4. Reinstall the fuse box cover.
5. Close and secure the front box and cover.

LIGHTS



Poor lighting can result in reduced visibility when driving. Headlight and taillight lenses become dirty during normal operation. Clean headlights frequently and replace burned out headlamps promptly.

Always make sure lights are adjusted properly for best visibility.

HEADLIGHT ADJUSTMENT

To adjust the front headlights, do the following:

1. Place the Quadricycle on a level surface with the headlight approximately (7 m) from a wall.

NOTICE

Rider weight must be included on the seat while performing this procedure.

2. Place the transmission in PARK.
3. Measure the distance from the floor to the center of the headlight and make a mark on the wall at the same height.
4. Turn ignition ON and switch the headlight to low beam.
5. Observe the headlight aim on the wall. The horizontal line, separating the lit-zone from the unlit-zone, should be aimed 8 in (20 cm) below the mark placed on the wall in step 3.

MAINTENANCE

- Open the front rack.
- Adjust the beam to desired position by tightening or loosening the screws at the top of the lights. Adjust each light independently.

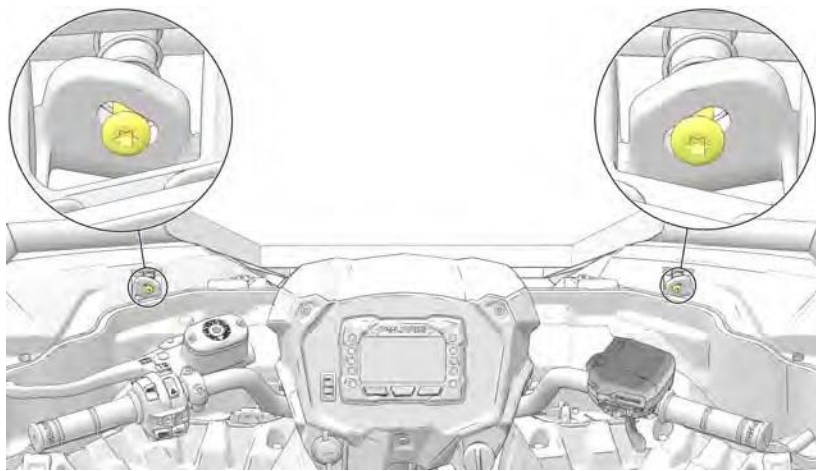

WARNING

Due to the nature of ATVs and where they are operated, headlight lenses can become dirty. Frequent washing is necessary to maintain lighting quality. Riding with poor lighting can result in severe injury or death.

HALOGEN HEADLIGHT BULB REPLACEMENT — (IF EQUIPPED)

To replace the headlight bulb, do the following:

- Disconnect the headlight harness ① and pull the harness away from the headlight assembly. Be sure to pull on the connector, not on the wiring.
- Remove the rubber cap ② from the back of the housing.
- Turn the plastic collar ③ counterclockwise to access the bulb.

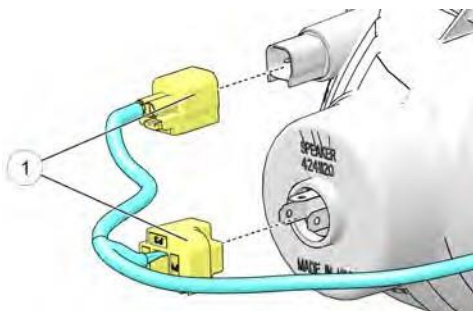

4. Remove the bulb and replace with a new bulb.
5. Re-attach plastic collar and turn clockwise to secure.
6. Install the rubber cap and re-connect the harness to the headlight assembly.

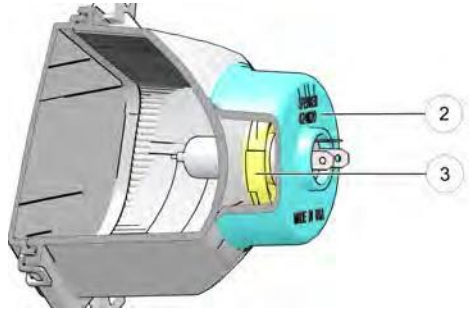

LED HEADLIGHT REPLACEMENT — (IF EQUIPPED)

If the headlights become inoperable, the entire assembly must be replaced by your authorized Egimotors dealer or other qualified service facility.

CAMBER AND CASTER

The camber and caster are non-adjustable.

SHOCK SPRINGS

The shock absorber springs are adjusted by rotating the cam either clockwise or counterclockwise to increase or decrease spring tension.

- ① Cam
- ② High Tension
- ③ Low Tension

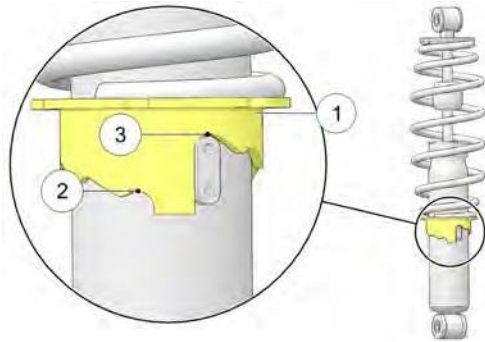

MAINTENANCE

HANDLEBARS

The handlebars can be adjusted for rider preference.

WARNING

Improper adjustment of the handlebars or incorrect torquing of the adjuster block tightening bolts can cause limited steering or loosening of the handlebars, resulting in loss of control and serious injury or death. Follow the adjustment procedures exactly or see your authorized dealer for service.

1. Remove the upper headlight pod (if equipped).
2. Loosen the four handlebar bolts  and adjust the handlebar to the desired height.
3. Be sure the handlebars do not contact the gas tank or any other part of the machine when turned fully to the left or right.
4. Torque the front two bolts to 14-17 Nm, then torque the rear two bolts. A gap up to 3 mm will remain at the rear of the clamp blocks.

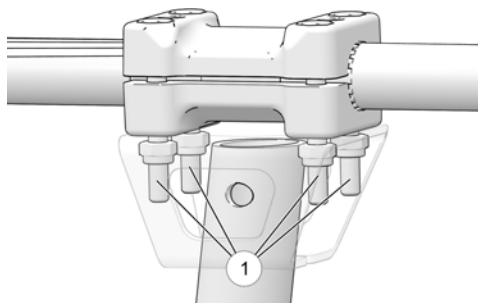

SPARK PLUGS

SPARK PLUG RECOMMENDATIONS

Refer to the Specifications section for the recommended spark plug type and gap for your Quadricycle.

NOTICE

Using non-recommended spark plugs can result in serious engine damage. Always use EGIMOTORS-recommended spark plugs.

PLUG CONDITION	TORQUE SPECIFICATION
New Spark Plug	24-27 Nm
Previously Installed Spark Plug	24-27 Nm

SPARK PLUG INSPECTION

Spark plug condition is indicative of engine operation. Check the spark plug firing end condition after the engine has been warmed up and the Quadricycle has been driven at higher speeds. Immediately check the spark plug for correct color.

 **CAUTION**

A hot exhaust system and engine can cause burns. Wear protective gloves when removing a spark plug for inspection. Allow engine to cool before removing spark plug wire.

1. Rotate the spark plug cap 1/4 turn and pull it off the spark plug.
2. Rotate the spark plug counterclockwise to remove it.
3. Reverse the procedure for spark plug installation. Torque to specification.

NORMAL PLUG

The normal insulator tip is gray, tan or light brown. There will be few combustion deposits. The electrodes are not burned or eroded. This indicates the proper type and heat range for the engine and the service.

The tip should not be white. A white insulator tip indicates overheating, caused by use of an improper spark plug or incorrect throttle body adjustments.

MAINTENANCE

WET FOULED PLUG

The wet fouled insulator tip is black. A damp oil film covers the firing end. There may be a carbon layer over the entire nose. Generally, the electrodes are not worn. General causes of fouling are excessive oil, use of non-recommended oil or poor fuel quality.

QUADRICYCLE IMMERSION

If your Quadricycle becomes immersed, major engine damage can result if the machine is not thoroughly inspected. Take the Quadricycle in for service before starting the engine. Your EGIMOTORS dealer can provide this service.

If it's impossible to take your QUADRICYCLE to a dealer before starting it, follow the steps outlined below.

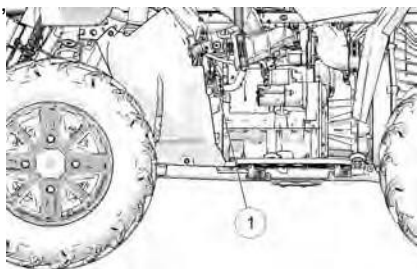

1. Move the QUADRICYCLE to dry land or at the very least, to water below the footrests.
2. Check the air box. If water is present, dry the air box and replace the filter with a new filter. If equipped, remove the air box drain plug ① to drain water. Reinstall the drain plug. Make sure the O-ring is on the drain plug and reinstall the drain plug.

NOTICE

Serious damage could occur if the air box drain plug is not reinstalled and tightened properly.

3. Remove the spark plugs.
4. Turn the engine over several times using the electric start.
5. Dry the spark plugs. Reinstall the plugs or install new plugs.
6. Attempt to start the engine. If necessary, repeat the drying procedure.

NOTICE

Serious damage can occur after immersion if fluids are not changed promptly. Your authorized dealer can assist.

7. Take the Quadricycle in for service as soon as possible, whether you succeed in starting it or not. Your authorized dealer can provide the required service.
8. If water has been ingested into the PVT, follow the procedure in the PVT System section for drying out the PVT.

SPARK ARRESTER

WARNING

- Never operate the Quadricycle without the spark arrester.
- Remove any combustible materials from the area.

Failure to heed the following warnings while servicing the spark arrester could result in serious injury or death.

- Never run the engine in an enclosed area. Exhaust contains poisonous carbon monoxide gas that can cause loss of consciousness or death in a very short time.
- Do NOT perform service on the spark arrester while the system is HOT. Exhaust system temperatures can reach extreme temperatures. Allow components to cool sufficiently before proceeding.
- Do not stand behind or in front of the Quadricycle while purging the exhaust system.
- Never go under the Quadricycle while it is inclined.
- Wear eye protection and gloves while servicing.

Periodically clean the spark arrester to remove accumulated carbon.

1. Place the transmission in PARK.
2. Remove the arrester retaining bolt and nut.
3. Remove the arrester from the end of the muffler.
4. Use non-synthetic brush to clean the arrester screen. A synthetic brush may melt if the components are warm. If necessary, blow debris from the screen with compressed air.
5. Inspect the screen for wear and damage. Replace a worn or damaged screen.
6. Reinstall the arrester.
7. Torque the bolt to specification.

TORQUE

Spark Arrester Retaining Bolt: (12–15 Nm)

PVT SYSTEM

WARNING

Failure to comply with the instructions in this warning can result in severe injury or death.

Do not modify any component of the PVT system. Doing so may reduce its strength so that a failure may occur at a high speed. The PVT system has been precision balanced. Any modification will cause the system to be out of balance, creating vibration and additional loads on components.

The PVT system rotates at high speeds, creating large amounts of force on clutch components. Extensive engineering and testing have been conducted to ensure the safety of this product. However, as the owner, you have the following responsibilities to make sure this system remains safe:

- Always follow all recommended maintenance procedures. Always look for and remove debris inside and around the clutch and vent system when replacing the belt.
- See your dealer as outlined in the owner's manual.
- This PVT system is intended for use on EGIMOTORS products only. Do not install it in any other product.
- Always make sure the PVT housing is securely in place during operation.

The basic operation of the EGIMOTORS PVT system is dependent on engine speed and Quadricycle torque requirements. As engine speed increases, the force exerted on the movable drive sheave by the flyweights also increases. This, in turn, increases the amount of pinch applied to the drive belt. Similarly, if the engine speed decreases, the amount of centrifugal force decreases, reducing the amount of belt pinch.

The approximate gear ratio difference between high and low range is 1:2.25. This difference in gearing affects the operation of the PVT, especially at speeds less than (11 km/h), due to the system's dependence on engine speed.

For example, when operating at a ground speed of (5 km/h) in low range, the engine speed would be around 3000 RPM. This is well above the engagement speed of 1600 - 1800 RPM. However, in high range at (5 km/h), the engine would be running at only 1500 RPM. Whenever operating this close to the engagement speed, the engine may be running at a speed too low to provide the pinch needed to prevent belt slip. Belt slip is responsible for creating the excessive heat that destroys belts, wears clutch components and causes outer clutch covers to fail.

The air temperature in the clutch cover is substantially reduced by using low range while operating at low ground speeds. Reducing the temperature inside the clutch cover greatly extends the life of the PVT components (belt, cover, etc.).

WHEN TO USE LOW AND HIGH RANGE

CONDITION	RANGE TO USE
Operating at speeds less than 11 km/h	Low
Towing heavy loads	Low
Operating in rough terrain (swamps, mountains, etc.)	Low
Operating at speeds greater than 11 km/h	High

PVT DRYING

There may be some instances when water is accidentally ingested into the PVT system. Use the following instructions to dry it out before operating.

1. Position the Quadricycle on a level surface.
2. Remove the drain plug. Allow the water to drain completely. Reinstall the drain plug.
3. Start the engine. Place the transmission in PARK.
4. Apply varying throttle for 10-15 seconds to expel the moisture and air-dry the belt and clutches. Do not hold the throttle wide open for more than 5 seconds.
5. Allow the engine RPM to settle to idle speed, then shift the transmission to low range.
6. Test for belt slippage. If the belt slips, repeat the process. Your Quadricycle requires service as soon as possible, which your authorized dealer can provide.

BATTERY

 **WARNING**

Improperly connecting or disconnecting battery cables can result in an explosion and cause serious injury or death. When removing the battery, always disconnect the negative (black) cable first. When reinstalling the battery, always connect the negative (black) cable last.

Your QUADRICYCLE is equipped with a sealed battery, which requires little maintenance. EGIMOTORS does not recommend using a conventional battery in this Quadricycle. The orientation of the battery could result in electrolyte leakage, which would shorten the life of the battery considerably.

Always keep battery terminals and connections free of corrosion. If cleaning is necessary, remove corrosion with a stiff wire brush. Wash with a solution of one tablespoon baking soda and one cup water. Rinse well with tap water and dry off with clean shop towels. Coat the terminals with dielectric grease or petroleum jelly.

BATTERY REMOVAL

1. Access the battery under the front box.
2. Disconnect the black (negative) battery cable first.
3. Disconnect the red (positive) battery cable last.
4. Disconnect the battery hold-down strap.
5. Lift the battery out of the QUADRICYCLE.

BATTERY INSTALLATION

Using a new battery that has not been fully charged can damage the battery and result in a shorter life. It can also hinder Quadricycle performance. Follow the instructions in the Battery Charging section before installing the battery.

An optional extreme use battery may be available for your model. If the performance of the factory-installed battery is inadequate due to operation in extreme cold or due to extended use of multiple electrical accessories, your authorized dealer can assist. Your dealer can provide any installation procedures that may differ for an extreme use battery.

1. Ensure that the battery is fully charged.
2. Place the battery in the battery holder.
3. Coat the terminals with dielectric grease or petroleum jelly.
4. Secure the battery hold-down strap.

5. Connect and tighten the red (positive) cable first.
6. Connect and tighten the black (negative) cable last.
7. Verify that cables are properly routed. Cables should be safely tucked away at the front and rear of the battery.
8. Close and secure the front box and cover.

BATTERY STORAGE

Whenever the Quadricycle is not used for a period of three months or more, remove the battery from the Quadricycle, ensure that it's fully charged, and store it out of the sun in a cool, dry place. Check battery voltage each month during storage and recharge as needed to maintain a full charge.

EGIMOTORS recommends maintaining battery charge by using a EGIMOTORS Battery Tender charger or by charging about once a month to make up for normal

self-discharge. Battery Tender can be left connected during the storage period, and will automatically charge the battery if the voltage drops below a pre-determined point. See the Egimotors Products section for the part numbers.

BATTERY CHARGING

The following battery charging instructions apply only to the installation of a sealed battery. Read all instructions before proceeding with the installation of this battery.

The sealed battery is already filled with electrolyte and has been sealed and *fully charged* at the factory. *Never* pry the sealing strip off or add any other fluid to this battery.

The single most important thing about maintaining a sealed battery is to keep it fully charged. Since the battery is sealed and the sealing strip cannot be removed, you must use a voltmeter or multimeter to measure DC voltage.

WARNING

An overheated battery may explode, causing severe injury or death. Always watch charging times carefully. Stop charging if the battery becomes very warm to the touch. Allow it to cool before resuming charging.

MAINTENANCE

For a refresh charge, follow all instructions carefully.

1. The battery should be disconnected from a load or charger for at least two hours before checking voltage. Check the battery voltage with a voltmeter or multimeter. A fully charged battery will register 12.8 V or higher.
2. If the voltage is less than 12.8 volts, recharge the battery at 1.2 amps or less until battery voltage is 12.8 or greater.
3. When using an automatic charger, refer to the charger manufacturer's instructions for recharging. When using a constant current charger, use the following guidelines via the table below.

BATTERY CHARGING (SEALED BATTERY)

Always verify battery condition before and 1-2 hours after the end of charging.

STATE OF CHARGE	VOLTAGE	ACTION	CHARGE TIME (USING CONSTANT CURRENT CHARGER @ STANDARD AMPS SPECIFIED ON TOP OF BATTERY)
100%	12.8-13.0 volts	None, check at 3 mos. from date of manufacture	None required
75%-100%	12.5-12.8 volts	May need slight charge, if no charge given, check in 3 months	3-6 hours
50%-75%	12.0-12.5 volts	Needs charge	5-11 hours
25%-50%	11.5-12.0 volts	Needs charge	At least 13 hours, verify state of charge
0%-25%	11.5 volts or less	Needs charge with desulfating charger	At least 20 hours

CLEANING AND STORAGE

WASHING THE QUADRICYCLE

Keeping your EGIMOTORS Quadricycle clean will not only improve its appearance, but it can also extend the life of various components.

NOTICE

High water pressure may damage components. EGIMOTORS recommends washing the Quadricycle by hand or with a garden hose, using mild soap. Certain products, including insect repellents and chemicals, will damage plastic surfaces.

Do not allow these types of products to contact the Quadricycle.

The best and safest way to clean your EGIMOTORS Quadricycle is with a garden hose and a pail of mild soap and water.

1. Use a professional type washing cloth, cleaning the upper body first and the lower parts last.
2. Rinse with clean water frequently.
3. Dry surfaces with a chamois to prevent water spots.

WASHING TIPS

- Avoid the use of harsh cleaners, which can scratch the finish.
- Do not use a power washer to clean the Quadricycle.
- Do not use medium to heavy duty compounds on the finish.
- Always use clean cloths and pads for cleaning and polishing. Old or reused cloths and pads may contain dirt particles that will scratch the finish.

If a high-pressure water system is used for cleaning (not recommended), exercise extreme caution. The water may damage components and could remove paint and decals. Avoid directing the water stream at the following items:

- Wheel bearings
- Radiator
- Transmission seals
- Cab and body panels
- Electrical components
- Switches and controls
- Fuel system components
- Labels and decals

MAINTENANCE

If an informational or graphic label becomes illegible or comes off, contact your EGIMOTORS dealer to purchase a replacement.

Grease all zerk fittings immediately after washing. Allow the engine to run for a while to evaporate any water that may have entered the engine or exhaust system.

POLISHING THE QUADRICYCLE

EGIMOTORS recommends the use of common household aerosol furniture polish for polishing the finish on your EGIMOTORS Quadricycle. Follow the instructions on the container.

POLISHING TIPS

- Avoid the use of automotive products, some of which can scratch the finish of your Quadricycle.
- Always use clean cloths and pads for cleaning and polishing. Old or reused cloths and pads may contain dirt particles that will scratch the finish.

STORAGE TIPS

NOTICE

Starting the engine during the storage period will disturb the protective film created by fogging and damage could occur. Never start the engine during the storage period.

CLEAN THE EXTERIOR

Make any necessary repairs and clean the Quadricycle as recommended. See the Washing the Quadricycle section.

STABILIZE THE FUEL

1. Fill the fuel tank.
2. Add EGIMOTORS Carbon Clean Fuel Treatment or EGIMOTORS Fuel Stabilizer or equivalent fuel treatments or stabilizers. Follow the instructions on the container for the recommended amount. Carbon Clean removes water from fuel systems, stabilizes fuel and removes carbon deposits from pistons, rings, valves and exhaust systems.
3. Allow the engine to run for 15-20 minutes to allow the stabilizer to disperse through the entire fuel delivery system.

OIL AND FILTER

Change the oil and filter. See the Engine Oil section.

AIR FILTER / AIR BOX

Replace the air filter. See Maintenance Chapter. Clean the air box.

FLUID LEVELS

Inspect the fluid levels. Add or change fluids as recommended in the Periodic Maintenance Chart.

- Demand drive fluid (front gearcase)
- Rear gearcase fluid (if equipped)
- Transmission fluid
- Brake fluid (change every two years and any time the fluid looks dark or contaminated)
- Coolant (test strength/fill)

FOG THE ENGINE

1. Treat the fuel system with EGIMOTORS Carbon Clean or other equivalent fuel treatment. Follow the instructions on the container. Start the engine. Allow it to idle for several minutes so the Carbon Clean reaches the injectors. Stop the engine.
2. Remove the spark plugs and add (29.5–44 cc.) of engine oil. To access the plug holes, use a section of clear 6 mm hose and a small plastic squeeze bottle filled with the pre-measured amount of oil. *Do this carefully! If you miss the plug holes, oil will drain from the spark plug cavities into the hole at the front of the cylinder head and appear to be an oil leak.*
3. Reinstall the spark plugs. Torque to specification.
4. Apply dielectric grease to the inside of each spark plug cap. *Do not reinstall the cap onto the plug at this step.*
5. Turn the engine over several times. Oil will be forced in and around the piston rings and ring lands, coating the cylinder with a protective film of fresh oil.
6. Reinstall the spark plug caps.
7. If EGIMOTORS fuel system additive is not used, fuel tank, fuel lines, and injectors should be completely drained of gasoline.

INSPECT AND LUBRICATE

Inspect all cables and lubricate all areas of the Quadricycle as recommended in the Periodic Maintenance Chart.

BATTERY MAINTENANCE

Remove the battery and recharge it as outlined in the Battery Charging section. Store the battery in a cool, dry place.

MAINTENANCE

STORAGE AREA / COVERS

Be sure the storage area is well ventilated. Cover the Quadricycle with a genuine EGIMOTORS cover. Do not use plastic or coated materials. They do not allow enough ventilation to prevent condensation and may promote corrosion and oxidation.

ACCESSORIES

Auxiliary power outlets provide 12-volt power for operating accessories. Accessory outlets are available for all models. EGIMOTORS also has a wide range of additional accessories available for your QUADRICYCLE. Always install accessories that are approved for QUADRICYCLE use. Your dealer can assist.

TRAILERING YOUR QUADRICYCLE

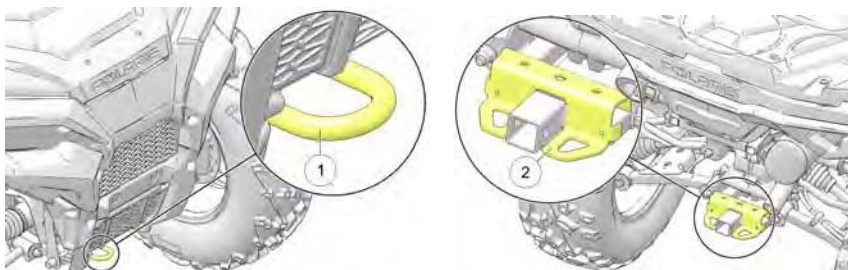

Follow these procedures when transporting the Quadricycle.

1. Stop the engine.
2. Place the transmission in PARK.
3. Secure the fuel cap, oil cap, and seat.
4. Remove the key to prevent loss during transporting.
5. Use suitable straps or rope to secure the Quadricycle to the front tow hook ① and rear tow bracket ②. Do not attach tie straps to the front A-arm bolt pockets, racks, or handlebars.

DIAGNOSTIC DISPLAY CODES

DIAGNOSTIC DISPLAY CODE DEFINITIONS

Open Load: There is a break in the wires that lead to the item listed in the chart (injector, fuel pump, etc.), or the item has failed.

Short-to-Ground: The wire is shorted to ground between the electronic control unit and the item listed in the chart.

Shorted Load: The wires leading to the item listed in the chart are shorted together, or the item has shorted internally.

Short-to-Battery: The wire leading from the item listed in the chart to the electronic control unit is shorted to a wire at battery voltage.

DIAGNOSTIC CODES			
COMPONENT	CONDITION	SPN	FMI
Throttle Position Sensor	Voltage Too High	51	3
	Voltage Too Low	51	4
Engine Temperature Sensor	Voltage Too High	110	3
	Voltage Too Low	110	4
	Temperature Too High	110	16
	Engine Overheat Shutdown	110	0
Intake Air Temperature Sensor	Voltage Too High	105	3
	Voltage Too Low	105	4
Manifold Absolute Pressure Sensor	Voltage Too High	102	3
	Voltage Too Low	102	4
	Signal Out of Range	102	2
Crankshaft Position Sensor	Circuit Fault	636	8
	Plausibility Fault	636	2
Quadricycle Speed Signal	Speed Too High	84	8
	Plausibility Fault	84	2
Gear Sensor Signal	Voltage Too Low	523	4
	Voltage Too High	523	3

DIAGNOSTIC DISPLAY CODES

DIAGNOSTIC CODES			
COMPONENT	CONDITION	SPN	FMI
	Signal Fault	523	2
Injector 1 (MAG) (SDI Part Load)	Driver Circuit Open/Grounded	651	5
	Driver Circuit Short to B+	651	3
	Driver Circuit Grounded	651	4
Injector 2 (PTO) (SDI Part Load)	Driver Circuit Open/Grounded	652	5
	Driver Circuit Short to B+	652	3
	Driver Circuit Grounded	652	4
Ignition Coil Primary Driver 1 (MAG)	Driver Circuit Short to B+	1268	3
Ignition Coil Primary Driver 2 (PTO)	Driver Circuit Short to B+	1269	3
Fuel Pump Driver Circuit	Driver Circuit Open/Grounded	1347	5
	Driver Circuit Short to B+	1347	3
	Driver Circuit Grounded	1347	4
Fan Relay Driver Circuit	Driver Circuit Open/Grounded	1071	5
	Driver Circuit Short to B+	1071	3
	Driver Circuit Grounded	1071	4
Idle Air Control	Driver Circuit Open/Grounded	634	5
	Driver Circuit Short to B+	634	3
	Driver Circuit Grounded	634	4
	Position Out of Range	634	7

DIAGNOSTIC DISPLAY CODES

DIAGNOSTIC CODES			
COMPONENT	CONDITION	SPN	FMI
Starter Enable Circuit	Driver Circuit Open/Grounded	1321	5
	Driver Circuit Short to B+	1321	3
	Driver Circuit Grounded	1321	4
Chassis Relay	Driver Circuit Open/Grounded	520208	5
	Driver Circuit Short to B+	520208	3
	Driver Circuit Grounded	520208	4
All Wheel Drive Control	Driver Circuit Open/Grounded	520207	5
	Driver Circuit Short to B+	520207	3
	Driver Circuit Grounded	520207	4
System Power	Voltage Too High	168	3
	Voltage Too Low	168	4
Throttle Safety Signal	Voltage Too High	520194	3
	Voltage Too Low	520194	4
	Signal Out of Range	520194	2
	Throttle Stuck	520194	7
Active Descent Control System	Driver Circuit Open/Grounded	520203	5
	Driver Circuit Short to B+	520203	3
	Driver Circuit Grounded	520203	4
Idle Speed	Speed Too High	520211	3
	Speed Too Low	520211	4
Right Hand Control	Momentary Driveline Mode Switch Press	520468	31

DIAGNOSTIC DISPLAY CODES

DIAGNOSTIC CODES			
COMPONENT	CONDITION	SPN	FMI
EPS MODELS ONLY			
Quadricycle Speed Sensor	Data Valid But Above Normal Operational Range - Most Severe Level	84	0
	Data Erratic, Intermittent Or Incorrect	84	2
	Abnormal Rate Of Change	84	10
	Received Network Data In Error	84	19
System Power	Data Valid But Above Normal Operational Range - Most Severe Level	168	0
	Voltage Above Normal, Or Shorted To High Source	168	3
	Voltage Below Normal, Or Shorted To Low Source	168	4
Engine Speed	Data Valid But Above Normal Operational Range - Most Severe Level	190	0
	Data Erratic, Intermittent Or Incorrect	190	2
	Received Network Data In Error	190	19
ECU Memory	Bad Intelligent Device Or Component	628	12
	Out Of Calibration	628	13
Calibration	Out Of Calibration	630	13
Steering Over Current Shut Down	Current Above Normal Or Grounded Circuit	520221	6
Steering Excessive Current Error	Current Above Normal Or Grounded Circuit	520222	6

DIAGNOSTIC DISPLAY CODES

DIAGNOSTIC CODES			
COMPONENT	CONDITION	SPN	FMI
EPS MODELS ONLY			
Steering Torque Partial Failure	Condition Exists	520223	31
Steering Torque Full Failure	Condition Exists	520224	31
EPAS Inverter Temperature	Data Valid But Above Normal Operational Range - Most Severe Level	520225	0
	Data Valid But Above Normal Operating Range - Moderately Severe Level	520225	16
EPAS Communications Receive Data Error	Data Erratic, Intermittent Or Incorrect	520226	2
	Condition Exists	520226	31
Position Encoder Error	Root Cause Not Known	520228	11
	Bad Intelligent Device Or Component	520228	12
	Condition Exists	520228	31
EPAS Software Error	Bad Intelligent Device Or Component	520229	12
	Condition Exists	520229	31
EPAS Power Save Condition	Condition Exists	520231	31
EPS SEPIC Voltage Error	Voltage Above Normal, Or Shorted To High Source	524086	3
	Voltage Below Normal, Or Shorted To Low Source	524086	4

SPECIFICATIONS

SCRAMBLER XP 1000

SCRAMBLER XP 1000 E	
Maximum Weight Capacity	180kg (includes operator, cargo and accessories)
Dry Weight estimated	375 kg
Fuel Capacity	20 L
Engine Oil Capacity	1.9 L
Coolant Capacity	1.9 L
Rear Gearcase Oil Capacity	210 ml
Demand Drive Fluid Capacity	275 ml
Transmission Oil Capacity	1100 ml
Front Rack Capacity	11 kg
Rear Rack Capacity	23 kg
Receiver Hitch Tongue Capacity	40 kg
Hitch Towing Rating	160 kg
Overall Length	226cm
Overall Width	122 cm
Overall Height	143 cm
Wheelbase	146 cm
Ground Clearance	30cm
Minimum Turning Radius	213 cm unloaded
Displacement	952 cc
Bore x Stroke	90.5 x 74
Alternator Output	475w @1200 RPM/Peak 630w
Compression Ratio	11:1
Starting System	Electric
Ignition System	Electronic Fuel Injection

SCRAMBLER XP 1000 E	
Ignition Timing	6° +/- 5° BTDC @ 1200 RPM
Idle RPM	1200 +/- 50
Throttle Body/Size	Mikuni® Dual Bore/42 mm
Spark Plug Type / Gap	AUTOLITE® 5682 / 0.76 mm
Throttle System	Electronic Throttle Control (ETC)
Lubrication System	Wet Sump
Driving System Type	Automatic PVT (EGIMOTORS Variable Transmission)
Front Suspension	Straight Dual A-Arm 9 in (23 cm) Travel
Rear Suspension	Straight Dual A-Arm, Rolled IRS, 10.25 in (26 cm) Travel
Transmission	H/L/N/R/P
Gear Reduction, Low	5.034:1
Gear Reduction, Reverse	4.508:1
Gear Reduction, High	2.367:1
Drive Ratio, Front	3.818:1
Drive Ratio, Rear	3.7:1
Tires/Pressure, Front	27x9-14 0,8 bar
Tires/Pressure, Rear	27x9-14 1 bar
Hand Brake	Single-Control Hydraulic Disc, All Wheel
Foot Brake	Foot-Activated Hydraulic Disc, All Wheel
Brake, Parking	Hydraulic Lock, All Wheel Mechanical Lock in PARK
Headlight	2 Hi/Lo beam on bumper (55/60 watt)
Taillight/Brake Light	LED
Instrument Cluster	Digital
12V DC Outlet	Yes

SPECIFICATIONS

SCRAMBLER XP 1000 SE	
Maximum Weight Capacity	180kg (includes operator, cargo and accessories)
Dry Weight estimated	398 kg
Fuel Capacity	20 L
Engine Oil Capacity	1.9 L
Coolant Capacity	1.9 L
Rear Gearcase Oil Capacity	210 ml
Demand Drive Fluid Capacity	275 ml
Transmission Oil Capacity	1100 ml
Front Rack Capacity	11 kg
Rear Rack Capacity	23 kg
Receiver Hitch vertical Capacity	40 kg
Hitch Towing Rating	160 kg on level ground
Overall Length	226.5 cm
Overall Width	143 cm
Overall Height	125.7 cm
Wheelbase	146 cm
Ground Clearance	30 cm
Minimum Turning Radius	213 cm unloaded
Displacement	952 cc
Bore x Stroke	90.5 x 74
Alternator Output	475w @1200 RPM/Peak 630w
Compression Ratio	11:1
Starting System	Electric
Ignition System	Electronic Fuel Injection

SPECIFICATIONS

SCRAMBLER XP 1000 SE	
Ignition Timing	6° +/- 5° BTDC @ 1200 RPM
Idle RPM	1200 +/- 50
Throttle Body/Size	Mikuni® Dual Bore/42 mm
Spark Plug Type / Gap	AUTOLITE® 5682 / 0.76 mm
Throttle System	Electronic Throttle Control (ETC)
Lubrication System	Wet Sump
Driving System Type	Automatic PVT (EGIMOTORS Variable Transmission)
Front Suspension	Straight Dual A-Arm 9 in (23 cm) Travel
Rear Suspension	Straight Dual A-Arm, Rolled IRS, 10.25 in (26 cm) Travel
Transmission	H/L/N/R/P
Gear Reduction, Low	5.034:1
Gear Reduction, Reverse	4.508:1
Gear Reduction, High	2.367:1
Drive Ratio, Front	3.818:1
Drive Ratio, Rear	3.7:1
Tires/Pressure, Front	27x9-14 0,8 bar
Tires/Pressure, Rear	27x9-14 1 bar
Hand Brake	Single-Control Hydraulic Disc, All Wheel
Foot Brake	Foot-Activated Hydraulic Disc, All Wheel
Brake, Parking	Hydraulic Lock, All Wheel Mechanical Lock in PARK
Headlight	2 Hi/Lo beam on bumper (55/60 watt)
Taillight/Brake Light	LED
Instrument Cluster	Digital
12V DC Outlet	Yes

SPECIFICATIONS

CLUTCHING

ALTITUDE		SHIFT WEIGHT	DRIVE CLUTCH SPRING	DRIVEN CLUTCH SPRING	HELIX
Meters	(0-6000)	24-70 PN 5633136	Red/Black Stripe PN 7043500	Black/White Lettering PN 7044086	58-66F Parallel BA PN 3235590
	(6000-12000)	24-68 PN 5632418	Red/Black Stripe PN 7043500	Black/White Lettering PN 7044086	58-66F Parallel BA PN 3235590

XP*EBS models require no helix/spring adjustment

TROUBLESHOOTING

DRIVE BELT WEAR / BURN

POSSIBLE CAUSE	SOLUTION
Driving onto a pickup or tall trailer in high range	Use low range during loading.
Starting out going up a steep incline	Use low range or turn around using the K-turn. See the Turning Around on a Hill section.
Driving at low RPM or ground speed (3-7 MPH)	Drive at a higher speed or use low range more frequently. See the When To Use Low Range and High Range section.
Insufficient warm-up at low ambient temperatures	Warm the engine at least 5 minutes. With the transmission in neutral, advance the throttle to about 1/8 throttle in short bursts, 5 to 7 times. The belt will become more flexible and prevent belt burning.
Slow/easy clutch engagement	Use the throttle quickly and effectively.
Towing/pushing at low RPM/low ground speed	Use low range only.
Utility use/plowing	Use low range only.
Stuck in mud or snow	Shift the transmission to low range and carefully use fast, aggressive throttle application to engage clutch. WARNING! Excessive throttle may cause loss of control and Quadricycle overturn.
Climbing over large objects from a stopped position	Shift the transmission to low range and carefully use fast, brief, aggressive throttle application to engage clutch. WARNING! Excessive throttle may cause loss of control and Quadricycle overturn.
Belt slippage from water or snow ingestion into the PVT system	Dry out the PVT. See the PVT Drying section. Inspect clutch seals for damage if repeated leaking occurs.
Clutch malfunction	See your dealer.

TROUBLESHOOTING

POSSIBLE CAUSE	SOLUTION
Poor engine performance	Check for fouled plugs or foreign material in gas tank or fuel lines. See your dealer.
Slippage from failure to warm up belt	Always warm up the belt by operating below 30 mph for one mile (5 miles or more when temperature is below freezing).
Wrong or missing belt	Install the recommended belt.
Improper break-in	Always break in a new belt and/or clutch. See the PVT Break-in (Clutches / Belt) section.
Low battery voltage	Recharge the battery to 12.8 VDC
Loose battery connections	Check all connections and tighten
Loose solenoid connections	Check all connections and tighten

ENGINE DOESN'T TURN OVER

POSSIBLE CAUSE	SOLUTION
Low battery voltage	Recharge the battery.
Loose battery connections	Check all connections and tighten.
Loose solenoid connections	Check all connections and tighten.
Loose electronic control box connections	Inspect, clean, reinstall connectors.

ENGINE TURNS OVER, FAILS TO START

POSSIBLE CAUSE	SOLUTION
Out of fuel	Refuel.
Water is present in fuel	Drain the fuel system and refuel.
Old or non-recommended fuel	Replace with fresh recommended fuel.
Fouled or defective spark plug	Inspect plug and replace if necessary.

POSSIBLE CAUSE	SOLUTION
No spark to spark plug	Inspect plug and replace if necessary.
Water or fuel in crankcase	Your authorized dealer can assist.
Low battery voltage	Recharge the battery to 12.8 VDC.
Mechanical failure	Your authorized dealer can assist.

ENGINE BACKFIRES

POSSIBLE CAUSE	SOLUTION
Weak spark from spark plug	Inspect, clean and/or replace spark plug
Incorrect spark plug gap or heat range	Set gap to specs or replace plug
Old or non-recommended fuel	Replace with fresh recommended fuel
Incorrectly installed spark plug wires	Your authorized dealer can assist
Mechanical failure	Your authorized dealer can assist
Loose ignition connections	Check all connections and tighten
Water present in fuel	Replace with fresh recommended fuel

ENGINE PINGS OR KNOCKS

POSSIBLE CAUSE	SOLUTION
Poor quality or low octane fuel	Replace with recommended fuel.
Incorrect ignition timing	Your authorized dealer can assist.
Incorrect spark plug gap or heat range	Set gap to specs or replace plugs.

ENGINE RUNS IRREGULARLY, STALLS OR MISFIRES

POSSIBLE CAUSE	SOLUTION
Fouled or defective spark plug(s)	Inspect, clean and/or replace spark plugs
Worn or defective spark plug wires	Your authorized dealer can assist

TROUBLESHOOTING

POSSIBLE CAUSE	SOLUTION
Incorrect spark plug gap or heat range	Set gap to specs or replace plugs
Loose ignition connections	Check all connections and tighten
Water present in fuel	Replace with new fuel
Low battery voltage	Recharge battery to 12.8 VDC
Kinked or plugged fuel tank vent line	Inspect and replace
Incorrect fuel	Replace with recommended fuel
Clogged air filter	Inspect and clean or replace
Reverse speed limiter malfunction	Your authorized dealer can assist
Electronic throttle control malfunction	Your authorized dealer can assist
Other mechanical failure	Your authorized dealer can assist

POSSIBLE LEAN FUEL CAUSE	SOLUTION
Low or contaminated fuel	Add or change fuel, clean the fuel system
Kinked or plugged fuel tank vent line	Inspect and replace
Low octane fuel	Replace with recommended fuel
Clogged air filter	Your authorized dealer can assist
Incorrect fuel	Replace with recommended fuel

POSSIBLE RICH FUEL CAUSE	SOLUTION
Fuel is very high octane	Replace with lower octane fuel
Stopping/starting without adequate warm-up	Allow engine to warm up before operating and/or stopping

POSSIBLE RICH FUEL CAUSE	SOLUTION
Incorrect fuel	Replace with recommended fuel
Clogged air filter	Inspect and clean or replace

ENGINE STOPS OR LOSES POWER

POSSIBLE CAUSE	SOLUTION
Out of fuel	Refuel, cycle key to ON position three times for 5 seconds each, then start
Kinked or plugged fuel vent line	Inspect and replace
Water is present in fuel	Replace with new fuel
Fouled or defective spark plug(s)	Inspect, clean and/or replace spark plugs
Worn or defective spark plug wires	Your authorized dealer can assist
Incorrect spark plug gap or heat range	Set gap to specs or replace plug
Loose ignition connections	Check all connections and tighten
Low battery voltage	Recharge the battery to 12.8 VDC
Incorrect fuel	Replace with fresh recommended fuel
Clogged air filter	Inspect and clean or replace
Reverse speed limiter malfunction	Your authorized dealer can assist
Electronic throttle control malfunction	Your authorized dealer can assist
Other mechanical failure	Your authorized dealer can assist
Overheated engine	Clean radiator screen and core, clean engine exterior. Your EGIMOTORS dealer can assist.

TROUBLESHOOTING

ENGINE OVERHEATING

POSSIBLE CAUSE	SOLUTION
Debris lodged in screen	Clean the screen
Plugged Radiator	Use a garden hose to flush any debris from the radiator fins. NOTE: High pressure washers can deform the radiator fins and reduce cooling efficiency.

WARRANTY

LIMITED WARRANTY

EGIMOTORS gives a TWO YEAR LIMITED WARRANTY on all components of your Quadricycle against defects in material or workmanship.

This warranty covers parts and labor charges for repair or replacement of defective parts and begins on the date of purchase by the original retail purchaser.

This warranty is transferable to another owner during the warranty period through a dealer, but any such transfer will not extend the original term of the warranty.

The duration of this warranty may vary by international region based upon local laws and regulations.

REGISTRATION

At the time of sale, the Warranty Registration Form must be completed by your dealer and submitted within ten days of purchase.

Upon receipt of this registration, EGIMOTORS will record the registration for warranty. No verification of registration will be sent to the purchaser as the copy of the Warranty Registration Form will be your proof of warranty coverage. If you have not signed the original registration and received the customer copy, please contact your dealer immediately.

NO WARRANTY COVERAGE WILL BE ALLOWED UNLESS YOUR VEHICLE IS REGISTERED WITH EGIMOTORS.

Initial dealer preparation and set-up of your vehicle is very important in ensuring trouble-free operation.

Purchasing a machine in the crate or without proper dealer set-up will void your warranty coverage.

WARRANTY

WARRANTY COVERAGE AND EXCLUSIONS LIMITATIONS OF WARRANTIES AND REMEDIES

This EGIMOTORS limited warranty excludes any failures that are not caused by a defect in material or workmanship. THIS WARRANTY DOES NOT COVER CLAIMS OF DEFECTIVE DESIGN. This warranty also does not cover acts of God, accidental damage, normal wear and tear, abuse or improper handling. This warranty also does not cover any Quadricycle, component, or part that has been altered structurally, modified, neglected, improperly maintained or used for racing, competition or purposes other than for which it was designed.

This warranty excludes damages or failures resulting from improper lubrication; improper engine timing; improper fuel; surface imperfections caused by external stress, heat, cold or contamination; operator error or abuse; improper component alignment, tension, adjustment or altitude compensation; snow, water, dirt or other foreign substance ingestion/contamination; improper maintenance; modified components; use of aftermarket or unapproved components, accessories, or attachments; use of unapproved software or calibration; unauthorized repairs; or repairs made after the warranty period expires or by an unauthorized repair center.

This warranty excludes damages or failures caused by abuse, accident, fire, or any other cause other than a defect in materials or workmanship and provides no coverage for consumable components, general wear items, or any parts exposed to friction surfaces, stresses, environmental conditions and/or contamination for which they were not designed or not intended, including but not limited to the following items:

- Wheels and tires
- Suspension components
- Brake components
- Seat components
- Clutches and components
- Steering components
- Batteries
- Light bulbs/Sealed beam lamps
- Filters
- Lubricants
- Bushings
- Finished and unfinished surfaces
- Carburetor/Throttle body components
- Engine components
- Drive belts
- Hydraulic components and fluids
- Circuit breakers/Fuses
- Electronic components
- Spark plugs
- Sealants
- Coolants
- Bearings

LUBRICANTS AND FLUIDS

1. Mixing oil brands or using non-recommended oil may cause engine damage. We recommend the use of POLARIS engine oil.
2. Damage or failure resulting from the use of non-recommended lubricants or fluids is not covered by this warranty.

This warranty provides no coverage for personal loss or expense, including mileage, transportation costs, hotels, meals, shipping or handling fees, product pick-up or delivery, replacement rentals, loss of product use, loss of profits, or loss of vacation or personal time.

THE EXCLUSIVE REMEDY FOR BREACH OF THIS WARRANTY SHALL BE, AT EGIMOTORS' OPTION, REPAIR OR REPLACEMENT OF ANY DEFECTIVE MATERIALS, COMPONENTS, OR PRODUCTS. THE REMEDIES SET FORTH IN THIS WARRANTY ARE THE ONLY REMEDIES AVAILABLE TO ANY PERSON FOR BREACH OF THIS WARRANTY. EGIMOTORS SHALL HAVE NO LIABILITY TO ANY PERSON FOR INCIDENTAL, CONSEQUENTIAL OR SPECIAL DAMAGES OF ANY DESCRIPTION, WHETHER ARISING OUT OF EXPRESS OR IMPLIED WARRANTY OR ANY OTHER CONTRACT, NEGLIGENCE, OR OTHER TORT OR OTHERWISE. THIS EXCLUSION OF CONSEQUENTIAL, INCIDENTAL, AND SPECIAL DAMAGES IS INDEPENDENT FROM AND SHALL SURVIVE ANY FINDING THAT THE EXCLUSIVE REMEDY FAILED OF ITS ESSENTIAL PURPOSE.

THE IMPLIED WARRANTY OF FITNESS FOR A PARTICULAR PURPOSE IS EXCLUDED FROM THIS LIMITED WARRANTY. ALL OTHER IMPLIED WARRANTIES (INCLUDING BUT NOT LIMITED TO THE IMPLIED WARRANTY OF MERCHANTABILITY) ARE LIMITED IN DURATION TO THE ABOVE TWO YEARS WARRANTY PERIOD. EGIMOTORS DISCLAIMS ALL EXPRESS WARRANTIES NOT STATED IN THIS WARRANTY. SOME STATES DO NOT PERMIT THE EXCLUSION OR LIMITATION OF INCIDENTAL OR CONSEQUENTIAL DAMAGES OR ALLOW LIMITATIONS ON THE DURATION OF IMPLIED WARRANTIES, SO THE ABOVE LIMITATIONS MAY NOT APPLY TO YOU IF INCONSISTENT WITH CONTROLLING STATE LAW.

WARRANTY

HOW TO OBTAIN WARRANTY SERVICE

If your Quadricycle requires warranty service, you must take it to a EGIMOTORS Servicing Dealer. When requesting warranty service, you must present your copy of the Warranty Registration Form to the dealer. (THE COST OF TRANSPORTATION TO AND FROM THE DEALER IS YOUR RESPONSIBILITY.) EGIMOTORS suggests that you use your original selling dealer; however, you may use any EGIMOTORS Servicing Dealer to perform warranty service.

IN THE COUNTRY WHERE YOUR PRODUCT WAS PURCHASED:

Warranty or Service Bulletin repairs must be done by an authorized EGIMOTORS dealer, or another qualified person. If you move or are traveling within the country where your product was purchased, Warranty and Service Bulletin repairs may be requested from any authorized EGIMOTORS dealer, or other qualified person, that sells the same line as your product.

OUTSIDE THE COUNTRY WHERE YOUR PRODUCT WAS PURCHASED:

If you are traveling temporarily outside the country where your product was purchased, you should take your product to an authorized EGIMOTORS dealer, or another qualified person. You must show the dealer photo identification from the country of the selling dealer's authorized location as proof of residence. Upon residence verification, the servicing dealer will be authorized to perform the warranty repair.

IF YOU MOVE:

If you move to another country, be sure to contact EGIMOTORS Customer Assistance and the customs department of the destination country before you move. Product importation rules vary considerably from country to country. You may be required to present documentation of your move to EGIMOTORS in order to continue your warranty coverage. You may also be required to obtain documentation from EGIMOTORS in order to register your product in your new country. You should warranty register your product at a local EGIMOTORS dealer in your new country immediately after you move to continue your warranty coverage and to ensure that you receive information and notices regarding your product.

IF YOU PURCHASE FROM A PRIVATE PARTY:

If you purchase a EGIMOTORS product from a private party, to be kept and used outside of the country in which the product was originally purchased, all warranty coverage will be denied. You must nonetheless register your product under your name and address with a local EGIMOTORS dealer in your country to ensure that you receive safety information and notices regarding your product.

EXPORTED PRODUCTS

EXCEPT WHERE SPECIFICALLY REQUIRED BY LAW, THERE IS NO WARRANTY OR SERVICE BULLETIN COVERAGE ON THIS PRODUCT IF IT IS SOLD OUTSIDE THE COUNTRY OF THE SELLING DEALER'S AUTHORIZED LOCATION. This policy does not apply to products that have received authorization for export from EGIMOTORS. Dealers may not give authorization for export. You should consult an authorized dealer to determine this product's warranty or service coverage if you have any questions. This policy does not apply to products registered to government officials or military personnel on assignment outside the country of the selling dealer's authorized location. This policy does not apply to Safety Bulletins.

NOTICE

If your product is registered outside of the country where it was purchased and you have not followed the procedure set above, your product will no longer be eligible for warranty or service bulletin coverage of any kind, other than safety bulletins. Products registered to government officials or military personnel on assignment outside of the country where the product was purchased will continue to be covered by the Limited Warranty.

Please work with your dealer to resolve any warranty issues. Dealership contacts can be found via this website, if needed:

www.Egimotors.it

Should your dealer require any additional assistance, they will contact the appropriate person at EGIMOTORS.

This warranty gives you specific legal rights, and you may also have other rights which vary from state to state or in different countries. If any of the above terms are void because of federal, state, local law, all other warranty terms will remain in effect.

For questions contact

EGIMOTORS Customer Assistance

Quadricycle Certificate of Pre-Delivery

Year _____ Model _____

VIN _____

Engine Serial Number _____

Key Number _____ Km / Hours _____

Registration Plate Number _____

ASSEMBLY / SERVICE / INSPECTION

- - SEALED BATTERY – Apply dielectric grease to terminal bolts and install cable. Check Voltage and charge if below 12,8 Volts.
- - BATTERY VOLTAGE – Misuse and record the battery voltage after 30 minutes after charger has been removed _____ DCV
- - TIRE PRESSURE – Verify Pressure if set to Specification
- - WHEEL NUT – Torque to specification
- - HANDLEBAR CLAMPS - Torque bolts to specification
- - MASTER CYLINDER – Torque bolts to specification
- - FRONT TOE ALIGNMENT – Verify proper toe setting
- - BALL JOINT – Inspect bolts and/or cotter pin
- - STEERING POST – Inspect cotter pin
- - TIE ROD – Inspect jam nuts and cotter pin
- - TRANSMISSION – Add oil if needed
- - GREASE FITTING – Check and Grease all the Fitting if needed
- - ENGINE OIL – Check level of oil, add if needed
- - BRAKE FLUID – Check level of fluid, add if needed in brake master cylinder(s)
- - ENGINE COOLANT – Inspect coolant in recovery bottle. Add if needed.
- - PARK BRAKE – Verify proper operation
- - INTAKE AIRBOX – Inspect hose connection and clamps. Inspect filter condition.
- - LIGHTS – Verify operation of all lights
- - FUEL – Check level of fuel and add if needed
- - WIRE HARNESS / HOSE/ LINES – Inspect wire, hoses, and line from kinks, pinching and sign of abrasion.
- - UNIT INQUIRY – Check in the system and complete applicable Service Bulletins Recalls or factory direct modification(s)
- - COSMETIC INSPECTION – Inspect the quadricycle for damage and proper fit and finish.

DEALERSHIP NAME _____ # _____

ASSEMBLED BY _____

DATE _____ / _____ / _____

SIGNATURE

STAMP

Quadricycle Certificate of Pre-Delivery

Year _____ Model _____

VIN _____

Engine Serial Number _____

Key Number _____ Km / Hours _____

Registration Plate Number _____

TEST RIDE

- - ENGINE – Starting acceleration and smoothness.
- - IDLE SPEED – Verify when cold and hot the engine idle properly.
- - TROTTLE – With engine idling and transmission in Neutral, swing the handlebar through entire travel range and verify proper and smooth operation.
- - ETC - Verify proper operation and throttle free play.
- - AUXILIARY SHUT OFF SWITCH - Verify proper operation.
- - BRAKES - Verify proper operation. Torque bolts to specification
- - DRIVELINE – Verify smooth operation
- - CLUTCH / TRANSMISSION – Verify proper shifting and transmission engagement/ indicator lights must correspond with gears.
- - AWD ADC – Verify proper operation.
- - REVERSE SPEED LIMITER – Verify operation and override control.
- - INSTRUMENTATION – Verify operational reading.
- - WHINCH (If equipped) – Verify proper operation.
- - SUSPENSION / STEERING – Verify adjustment, stability and operation.
- - ENGINE COOLANT Inspect coolant in recovery bottle between Min and Max after test ride, add if necessary.
- - DIAGNOSTIC SYSTEM – Run Engine up to full operating temperature. Use digital Wrench to generate and submit a "Service Report" recommended Process.
- - LEAKAGE – After completing "Diagnostic System" check for leakage and verify proper connection of oil / exhaust / fuel / Coolant / Brake fluid fitting, inspect hoses for sign and abrasion.
- - CLEAN – Wash and clean the quadricycle before delivery.

TEST RIDDEN BY

DATE _____ / _____ / _____

SIGNATURE

STAMP

Quadricycle Certificate of Pre-Delivery

Year _____ Model _____

VIN _____

Engine Serial Number _____

Key Number _____ Km / Hours _____

Registration Plate Number _____

DELIVERY TO CUSTOMER

- - WARRANTY REGISTRATION FORM – Completed and signed.
- - OWNERS MANUAL – Emphasize the importance of reading for customer Safety and Servicing of Quadricycle/ Explain periodic maintenance responsibilities.
- - WARRANTY POLICY – Explanation / Limit / Requirements.
- - KEYS - Record Key Number.
- - Controls – Show location and function.
- - BELT LIFE – Discuss proper operation procedure operating and proper use of High and Low Gear Range.
- - BREAK IN PROCEDURE – Review as outline in Owner's Manual.
- - STORAGE / FUELING / TRANSPORTATION – Review as outline in the owner's manual.
- - TOOL KIT – Show location.
- - Safety Video – Review with Customer.
- - SAFETY FEATURES – Review all safety features of quadricycle operation for new operation.
- - DRIVING PROCEDURE – Review Operator driving procedure outlined in the Owner's Manual.
- - SVIA TRAINING FACT SHEET – Review with customer.
- - SAFETY TRAINING COURSE SVIA – I have instructed the owner on the authorized SVIA Safety training online course.
- - PRE-DELIVERY CERTIFICATION – I certify that pre-delivery inspection and service have been performed on this vehicle in accordance with the instructions issued by Egimotors.

DEALERSHIP NAME _____ # _____

DELIVERED BY _____

DATE _____ / _____ / _____

SIGNATURE

STAMP

Quadricycle Certificate of Pre-Delivery

Year _____ Model _____

VIN _____

Engine Serial Number _____

Key Number _____ Km / Hours _____

Registration Plate Number _____

CUSTOMER ACCEPTANCE

- - I have reviewed the Egimotors warranty Policy / Policies
- - I have inspected the Quadricycle and it meets my satisfaction.
- - I understand the importance of following the Owner's Manual and instructions.

- - I understand the importance of using all safety features.

Review with customer.

- - I understand the importance of all operation following the operator driving procedures in the Owner's Manual.

- - I have been instructed on the authorized online SVIA training course by my Dealer _____

(Name of dealership and person who inform the Customer)

CUSTOMER NAME _____

CUSTOMER SIGNATURE

DATE _____ / _____ / _____

For more informations
visit www.Egimotors.it

Egimotors
Via Filippo da Desio 49/51
20832 Desio (MB) ITALY
info@polarisitalia.com