

Egimotors

2023

OWNER'S MANUAL

TRACTOR

RZR XP 1000 4S

Owner's manual part Number - OM23TRZRXP10004S

Read this manual carefully. It contains important safety information. This is an adult Tractor only.

Operation is prohibited for those under 18 years of age.

 **WARNING**

This Owner Manual refers to EGIMOTORS TRACTORS
(To be filled in by your Dealer)

This Owner's Manual must remain inside your Tractor
(Legal requirement)

A digital/printable copy is available on [www.Egimotors .it](http://www.Egimotors.it)

Model Type _____

Year _____

Code number (spare parts use only) _____

VIN Number _____

Engine Serial Number _____

Personal PIN Security Code: _____

Registration Plate Number _____

Thank you for purchasing an Egimotors Tractor, and welcome to our world-wide family of enthusiasts.

We have done This manual to inform you on how to use and maintain the best condition of operation for your Tractor.

If after reading this manual, you still have some questions please do not hesitate to contact your dealer that will be available to help you.

Be sure to visit us online at [www.Egimotors .it](http://www.Egimotors.it) for the latest news and for product and Safety information.

We believe we sets a standard of excellence for all utility and Tractor manufactured in the world today.

Many years of experience have gone into the engineering, design, and development of your Tractor, making it the finest machine we've ever produced.

For safe and enjoyable operation of your Tractor, be sure to follow the instructions and recommendations in this owner's manual.

Your manual contains instructions for the maintenance of the Tractor and information about repairs.

Service Manual are available from Dealers, only them can perform major repair and install accessory.

Your dealer knows your Tractor better than anyone and is interested in your total satisfaction, he can perform your service needs during and after the warranty period.

INTRODUCTION

IMPORTANT INFORMATION

WARNING

Failure to follow the warnings contained in this manual can result in severe injury or death.

This Tractor is not a toy and can be hazardous to operate. This Tractor handles differently than other Tractor. A collision or rollover can occur quickly, even during routine maneuvers, if you fail to take proper precautions.

- Read this owner's manual. Understand all safety warnings, precautions and operating procedures before operating the Tractor. Keep this manual with the Tractor at all times.
- This Tractor is an **ADULT TRACTOR ONLY**. You **MUST** be at least 18 years of age and have a valid driver's license to operate this Tractor.
- No person under the age of 12 may ride as a passenger in this Tractor.
- Never permit a guest to operate this Tractor unless the guest has read this manual and all product labels.
- Always keep hands, feet, and all other body parts inside the Tractor at all times.
- Always wear the proper clothing when operating or riding in this Tractor. All riders should wear substantial footwear, long pants, and a close-fitting shirt. A hard hat or helmet and approved eye protection are recommended when appropriate for riding or working conditions.
- Never operate this Tractor under the influence of drugs or alcohol, as these conditions impair judgement and the operator's ability to react.

TOOLS FOR SAFE RIDING

To safely operate this Tractor, it is important to become familiar with its features, controls, and characteristics. Review the Safety Briefings for this Tractor that apply to you:

- Operators
- Riders
- Owners
- Trailering the Tractor
- Maintaining the Tractor

Additionally, read the product safety labels on the Tractor and follow all rules and regulations concerning the operation of this Tractor in your area.

NEAR-FIELD COMMUNICATION (NFC) (IF EQUIPPED)

Some Egimotors Tractor come equipped with a near-field communication (NFC) chip. The NFC chip is embedded in the Egimotors emblem located at the front of the Tractor and seamlessly connects you to a digital platform of Tractor information and tools. See your dealer for more information.

IMPORTANT

Not all devices are equipped with an NFC reader. Additionally, some devices require third party applications to access NFC content. For questions regarding the NFC reader on your device, refer to the device's user manual.

On models equipped with NFC, place your smartphone directly over the Egimotors emblem to do the following:

- View Tractor-specific information
- Access your Egimotors Garage
- Download and view the owner's manual
- View accessory instructions
- Watch how-to videos
- Access warranty information
- Check for service notifications



RIDE COMMAND WITH NFC

Additional NFC features are available when using the Ride Command mobile app. To access these features, do the following:

1. Download the Ride Command mobile app from the Apple App Store® or Google Play® store.
2. Create or log in to an existing account.
3. From the Ride Command mobile app home screen, select **Add Tractor**.
4. On the Tractor, tap the NFC-enabled badge with the phone to scan the Tractor.
5. Confirm information, name your Tractor, and tap add to garage.

SYSTEM REQUIREMENTS

Refer to device manufacturer's instructions to verify NFC read capability, and/or NFC-capable add-ons.

TRACTOR IDENTIFICATION NUMBERS

Record your Tractor's identification number q, engine serial number w, and key number e in the spaces provided. Remove the spare key and store it in a safe place. An ignition key can be duplicated only by ordering a EGIMOTORS key blank (using your key number) and mating it with one of your existing keys. The ignition switch must be replaced if all keys are lost.

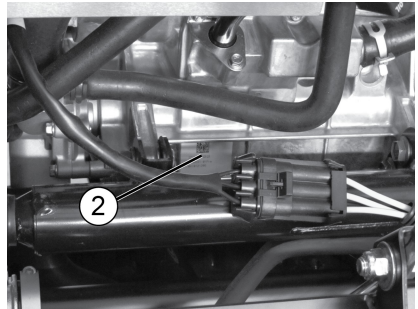
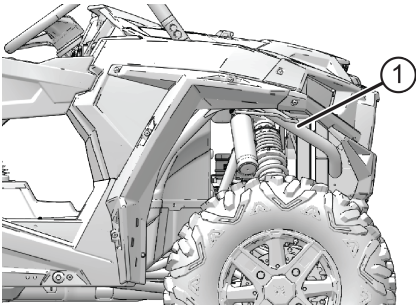
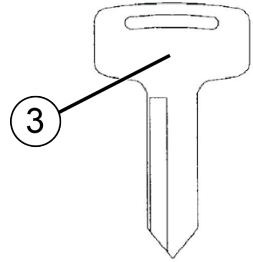

SAFETY

OWNER REQUIREMENTS

Improper use, maintenance, or modification of this Tractor can lead to serious injury or death.

Require proper use of your Tractor. Do not allow anyone to operate your Tractor or ride as a passenger unless they are properly instructed and you are sure they are willing to ride responsibly. To prevent unauthorized use, always remove the ignition key when the Tractor is not in use.



Any modifications or installation of non-POLARIS-approved accessories could increase the risk of injury. While you may find aftermarket products similar in design and quality to EGIMOTORS accessories, recognize that some aftermarket accessories or modifications are not suitable because of potential safety hazards to you or others. It is never appropriate to install any additional seating.

Check with the manufacturer to determine any potential effect of a modification or accessory on the safe use of your Tractor. You are responsible for injuries related to modifications to the Tractor. Modifications or accessories may:

- Damage machine components - especially modifications that increase speed or power.
- Make the Tractor less stable at higher speeds.
- Add weight, reducing the amount of cargo and total weight you can carry, and raise the Tractor's center of gravity.
- Overload the Tractor's electrical system capacity. Blowing a fuse may cause a loss of lights or engine power.
- Reduce the effectiveness of occupant protection systems, including the seatbelts and the Rollover Protective Structure (ROPS).
- Make it illegal to own or operate your Tractor. POLARIS-authorized spark arresters, mufflers, and emissions control components are mandatory for ownership or operation in many areas.
- Void your warranty.

The Tractor ROPS, when used with the seat belts and doors, provides a structure to help protect occupants. The structure will not protect occupants in all rollovers or accidents.

DRIVER AND PASSENGER QUALIFICATIONS

Make sure operators are 18 or older with a valid driver's license. Just because a teenager has a license does not mean that they will make good judgments about driving and avoid risk taking.

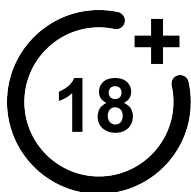
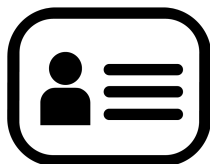

EGIMOTORS recommends that you supervise younger drivers. Set rules and put limits on how, when, and where they are allowed to use this Tractor. For example, young drivers may need to have an adult in the Tractor with them and not be allowed to drive with their friends in the Tractor.

Make sure all riders fit the Tractor. Be sure that the driver and all passengers are able to:

- sit with their backs against their seat,
- adjust the seat belt to fit properly,
- have both feet flat on the floor, and
- have both hands on the steering wheel or on a passenger hand hold.

Do not allow children who need child safety seats or booster seats to ride in the Tractor. The Tractor is not designed to restrain automotive child safety seats.

You are responsible for your passengers. Be sure passengers are seated properly, belted, holding the passenger hand hold, and ready to brace. Unrestrained riders can fall out or be thrown around and from a moving Tractor.

Every person must be properly seated and belted in their own seat. Two people should never be belted into a single seat belt. People belted together can crash into one another in a collision and be seriously injured. Never carry passengers in the cargo bed as they could be thrown against or out of the Tractor or come into contact with moving parts.

Do not let people drive or ride after using alcohol or drugs.

PREPARE TRACTOR FOR THE RIDE

Before starting off, always perform the Pre-Ride Inspection. Failure to inspect and verify that the Tractor is in safe operating condition increases the risk of an accident, which can lead to serious injury or death.



ITEM	REMARK
Brake Fluid	Ensure proper level and condition
Front and rear suspension	Inspect, lubricate if necessary
Steering	Ensure free operation
Tires	Inspect condition and pressure
Wheels/Lug Nuts	Inspect, ensure fastener tightness
Fuel and oil	Ensure proper levels and condition
Coolant	Ensure proper level and condition
Indicator lights/switches	Ensure proper operation
Air Filter	Inspect, replace as needed
Engine intake pre-filter	Inspect, clean
PVT intake pre-filter	Inspect, clean
Headlights	Check operation
Brake lights/taillights	Check operation
Seat Latches	Push down on both seat backs to ensure the latches are secure

SAFETY

ITEM	REMARK
Seat Belts	Check length of belt for damage, check latches for proper operation
Exhaust	Inspect spark arrester and clean if needed.
Tractor Debris	Remove grass, leaves, and other flammable material or debris, especially near the exhaust system.
Passenger Hand Hold	Always adjust the hand hold to a comfortable position for your passenger before operating. Make sure the clasps are fully locked after making adjustments.
Lock adjustable steering wheel	Do not adjust the steering wheel while the Tractor is moving.

Improper tire maintenance can lead to loss of control and an accident, which could result in serious injury or death. To reduce your risk of injury:

- Maintain EGMOTORS recommended tire pressure. Check pressure before operating. Even if your Tractor has only been driven a short distance, the tire pressure readings can become higher.
- Make sure tire pressures match the specifications listed in the table below.
- Only use the size and type of tires specified for this Tractor.
- Do not operate your Tractor with worn or damaged tires.
- Always follow your tire manufacturer's instructions for maintenance.

PREPARE YOURSELF, PASSENGERS, AND CARGO FOR THE RIDE

Wear an approved helmet. Riding in this Tractor without wearing an approved helmet increases the risk of serious injury. For example, a helmet reduces your risk of injury from head strikes with the Tractor or other objects even if there is no crash.

Approved helmets in the USA and Canada bear a U.S. Department of Transportation (DOT) label. Approved helmets in Europe, Asia, and Oceania bear the ECE 22.05 label. The ECE mark consists of a circle surrounding the letter E, followed by the distinguishing number of the country which has granted approval. The approval number and serial number will also be displayed on the label.

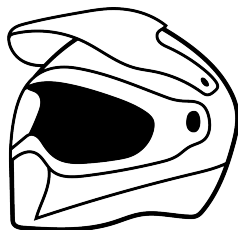

Use shatterproof goggles or a shatterproof helmet face shield. Such protective eyewear may reduce the risk of foreign material getting in your eyes and help prevent loss of vision.

EGIMOTORS recommends wearing approved Personal Protective Equipment (PPE) that have markings indicating they are designed to standards such as:

- CE



Additional protective clothing and gear that may be appropriate for your riding conditions includes:

- Always wear shoes when operating. Consider wearing sturdy over-the-ankle boots suitable for the terrain you will be riding in.
- Full-finger gloves can protect against wind, sun, cold, and objects. Choose gloves that fit snugly and allow fingers to move freely and grip on the steering wheel or hand holds.
- Consider long sleeves and long pants to help protect arms and legs.
- Long-term exposure to wind and engine noise can cause permanent hearing loss. Properly worn hearing protective devices such as earplugs can help prevent hearing loss. Check local laws or the rules of the riding area you are in before wearing hearing protection to make sure its use is permitted.

Always stay completely inside the Tractor and hold the steering wheel or hand holds. Body parts outside of the Tractor can be struck by passing objects or crushed during a rollover. Do not put any part of your body outside of the Tractor for any reason. Do not hold onto the ROPS frame or put any part of your body on the door.

Riding in this Tractor without closed and latched cab doors increases the risk of serious injury or death in the event of an accident or rollover. Always make sure all cab doors are closed and latched while riding in this Tractor.

Be sure riders pay attention and plan ahead. If you think or feel the Tractor may tip or roll, reduce your risk of injury:

- Keep a firm grip on the steering wheel or hand holds and brace yourself.
- Do not put any part of your body outside of the Tractor for any reason.

This Tractor is not designed to carry unrestrained pets. An unrestrained pet can be thrown about and injure riders, even during normal operation. When transporting pets, use a pet crate suitable for off-road use that is secured to the Tractor.

Fuels such as gasoline can be extremely flammable. To reduce the risk of serious injury or death, never carry fuel or other flammable liquids on this Tractor. Rollovers, crashes, rough riding, or changes in elevation or temperature may lead to fuel spilling or vapor release from portable containers. Hot Tractor parts can cause fires, even after the engine has been turned off.

Never exceed Tractor weight capacities. Overloading the Tractor or carrying cargo improperly will cause changes in stability and handling, which could cause loss of control or an accident. See the Specifications chapter for weight capacities.

Secure cargo in the cargo box as far forward, centered and as low as possible. When cargo cannot be positioned and secured in this way, operate with extra caution. Unsecured cargo can strike and injure riders, affect Tractor handling, and result in loss of control.

The weight of riders and cargo changes Tractor braking, handling, and stability. To avoid loss of control, turn gradually, operate at slower speeds, and avoid rougher or steeper terrain.

DRIVING GUIDELINES

Drive responsibly. This Tractor is not a toy and can be hazardous to operate. This Tractor has higher ground clearance and other features to handle rugged terrain. It can be overturned in situations where some other Tractor may not. Abrupt maneuvers or aggressive driving, even on flat, open areas, can cause loss of control, rollovers, severe injury or death. To avoid loss of control and rollovers:



- Avoid abrupt maneuvers, sideways sliding, skidding, or fishtailing, and never do donuts.
- Slow down before entering turn.
- Avoid hard acceleration when turning, even from a stop.

High speed off-road operation

Driving off-road Tractor to test the limits of your skills or abilities can be very dangerous to you, passengers, and bystanders. Basic skills for driving a car, ATV, or other off-road Tractor do not equip drivers to safely attempt high speed off-road operation. Develop your skill gradually through training, practice, and experience with the various driving modes of this Tractor and the terrain in which you are operating. Always do a low speed reconnaissance run (prerun) to become aware of anything you may encounter.

High speed off-road operation can lead to loss of control, crashes, or hard landings that can seriously injure occupants (even without rolling the Tractor or damaging it).

If you plan on using the Tractor for high speed, off-road competition, additional safety equipment may be necessary. Check the rules that apply to your competition.

Do not go over jumps — going airborne can lead to serious injury or death.

Going airborne can cause loss of control, rollovers, or crashing into the ground and may damage the Tractor. Even without crashing, landings can be hard enough to cause any Tractor suspension to fully compress (e.g., bottom out). Serious injuries, including spinal injuries, can occur even if riders are properly harnessed, wearing helmets and the Tractor is not damaged and remains upright.

You may encounter slopes, "jumps", or other terrain features that could send the Tractor airborne, depending on your speed. These may be defectively designed, poorly maintained, or not suitable for this Tractor. Slow down, use extra care, and avoid going airborne. Never take this Tractor over jumps.

Watching someone else go over a jump or go airborne does not mean you can safely do so. Egimotors cannot determine whether any jump you may encounter is appropriate for this Tractor. Any jump, even a small one, could be poorly maintained, designed, or not suitable for this Tractor and may cause serious injury or death.



Plan for hills, rough terrain, ruts, and other changes in traction and terrain.

Proceed slowly and with extra care on unfamiliar terrain. Avoid paved surfaces. Sudden changes in terrain such as holes, depressions, banks, softer or harder ground, or other irregularities may cause loss of control or rollover. Give yourself time to react to rocks, bumps, or holes that may be hard to see. Operating in deep snow or tall grass may make it harder to see obstacles.

If you cannot go around an obstacle, such as a fallen tree or a ditch, stop the Tractor in a safe place. Get out to inspect the area thoroughly. Look from both your approach side and exit side. If you are reasonably confident you can continue safely, choose the path that will allow you to go straight over the obstacle to minimize the Tractor tipping sideways. Go only fast enough to maintain your momentum, but still give yourself plenty of time to react to changes in conditions. If there is any question about your ability to maneuver safely over the obstacle, you should turn around if the ground is flat and you have the room, or back up until you find a less difficult path.

Abrupt application of the accelerator pedal can cause the tires to lose traction, reducing control of the Tractor and increasing the possibility of an accident, especially while on sloped terrain or while crossing obstacles such as rocks or logs.

SAFETY

TRACTOR MODELS ONLY

This Tractor is approved for on-road use, limited to local road and NOT HIGHWAYS

Improperly operating on hills can cause loss of control, rollover, or accident, which can lead to serious injury or death. Use extra care when operating on hills. Plan for rough terrain, ruts, and other changes in traction and terrain.

Driving up hills

Check the terrain before ascending a hill and make sure it is not too slippery or loose. Engage all-wheel drive for hills. Drive straight uphill, keeping speed and throttle steady. Avoid steep hills which can cause the Tractor to overturn.

Recovering from stalling on a hill

If the Tractor loses forward speed, apply the brakes gradually and stop. Do not attempt to turn the Tractor around. Instead, shift to reverse and allow the Tractor to slowly roll straight downhill. Apply light brake pressure to control speed.

Overtopping a hill

Slow down when you reach the crest of a hill. Never blindly go over the crest of a hill or a drop off at high speed. An obstacle, a sharp drop, or another Tractor or person could be on the other side of the hill.

Driving down hills

Check the terrain before descending a hill and make sure it is not too slippery or loose. Engage all-wheel drive and proceed slowly, applying the brakes lightly. Never descend a hill with the transmission in neutral or if the engine is turned off.

Avoid side hilling (riding across slopes)

If unavoidable, proceed slowly and with extra caution. Avoid obstacles and changes in terrain that could cause the Tractor to tip or slide. If it feels like the Tractor begins to tip or slide, immediately turn downhill.

Riding near wooded areas or brush

Use extra caution when operating near trees, particularly when operating on narrow trails. Tree branches or brush can be driven into the cab striking or stabbing occupants.



Riding in snow

Always keep the brake and accelerator pedals free of snow and ice. Apply the brakes frequently to prevent ice or snow accumulation on the brake pads which can reduce brake performance.

Riding on ice

Never operate the Tractor on a frozen body of water unless you have verified that the ice can support the weight of the Tractor. Severe injury or death can result if the Tractor falls through the ice.

Riding in water / Falling into water

Operating through deep or fast-flowing water can cause loss of traction, loss of control, overturning, or being swept away in water. You can be seriously injured or killed from entrapment and drowning. Never operate the Tractor in fast-flowing water or in water that exceeds the floor level of the Tractor. Avoid sharp drop-offs and large rocks. Choose a path that provides an entrance and exit point with gradual inclines. Wet brakes may have reduced stopping ability. After leaving water, test the brakes. Apply them lightly several times while driving slowly. The friction will help dry out the pads.

Riding on sand dunes

Use extra caution when operating on or near dunes. Be alert for changes in terrain. Never blindly go over the crest of a hill or a drop-off at high speed. An obstacle, a sharp drop, or another Tractor or a person could be on the other side of the hill.

Riding in low-visibility conditions

Use extra caution and drive slowly in conditions of reduced visibility such as fog, rain, and darkness.

Plan ahead to avoid the need for evasive maneuvers, such as swerving.

Hitting an obstacle — including wildlife — you are not ready for can be dangerous. Choosing to swerve instead can be even more dangerous because it can lead to loss of control, rollover, or collisions.

When operating in areas with possibility of wildlife appearing in your path, plan ahead to avoid swerving for animals if doing so could result in collisions or rollovers. Go slowly or avoid driving during seasons or times of day when animals such as deer are more likely to cross your path without warning.

SAFETY

Avoid Collisions With Other Tractor

When following another Tractor or operating in the same area as others, keep a safe distance to avoid collisions. Allow extra space when sight distances are limited by dust, snow, curves, hills, or other conditions. Plan ahead to avoid having to swerve or leave the trail to avoid a collision.

On trails, be prepared to make space for other Tractor to pass. If you need to stop on a trail, move your Tractor to the edge of the path to allow others to pass safely.

Correct a skid by turning the steering wheel in the direction of the skid.

Never apply the brakes during a skid.

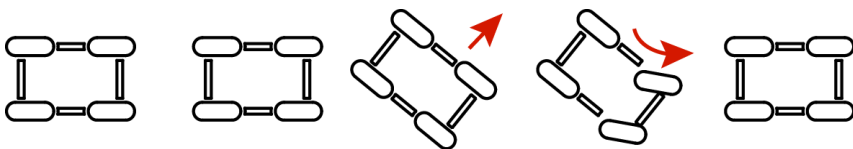

If the Tractor begins to slide downhill or you feel it may tip, turn downhill immediately and stop. Maneuver slowly and carefully until you can drive straight downhill.

Do not continue driving if your Tractor may be damaged or if you were in a crash or rollover.

Operating the Tractor while damaged or after a crash or rollover can cause loss of control, rollover, or accident, which can lead to serious injury or death. If you cannot safely transport the Tractor on your own, contact a recovery and towing service.

After any crash, rollover, or other accident, have a dealer inspect the Tractor for possible damage, including seat belts, ROPS, brakes, suspension, and steering systems.

Be prepared in case your Tractor becomes damaged or disabled, especially in remote areas. Consider in advance how to get help and stay safe until it arrives whenever you ride.

There is a recovery tow loop at the front and back of the Tractor to attach a winch or strap.

Use these loops to recover this Tractor if it is stuck, to pull it onto a tow truck, trailer, or to use this Tractor to recover another Tractor. These loops are for emergency recovery only and are not for towing Tractor to another location.

Improper recovery may lead to loss of control or Tractor damage. Only attach straps to specified locations. Do not attach to any other point on the Tractor. Only recover a Tractor of equal or lesser size and weight. When recovering a disabled Tractor, place the disabled Tractor's transmission in neutral. Do not move a disabled Tractor faster than 16 km/h.

Operating, Idling, Or Parking Near Combustible Materials

Engine, exhaust, and other Tractor components can be very hot during and after use. Do not idle or park the Tractor over anything that could contact the exhaust system and catch on fire, such as tall grass, weeds, brush, leaves, debris, or other tall ground cover. Do not let mud, grass, or other debris accumulate on the engine or exhaust system. Inspect and remove as needed.

Tractor rollaway can cause serious injury or death. This Tractor can roll whenever the gear selector is not in the PARK (P) position. Always shift to PARK (P) when stopping the engine or leaving the Tractor. When leaving the Tractor on an incline is unavoidable, use extra care. If leaving the Tractor unattended, block the rear wheels on the downhill side and keep children, pets, and others away from the gear selector.

Before shifting into reverse, use extra care to make sure the area is clear of people or obstacles. When it's safe to proceed, back slowly.

After operation, inspect the Tractor for damage and debris to make sure the Tractor can be safely stored and operated again. Some things to inspect include:

- Debris that could catch fire, such as mud/grass near the engine or exhaust system
- Damage to the suspension, steering, or any other part of the Tractor
- Tire condition, such as tread and sidewall damage
- Shock absorber assembly condition

Be sure to have any issues checked and problems fixed before operating again.

All engine exhaust contains carbon monoxide, a deadly gas. Breathing carbon monoxide can cause headaches, dizziness, drowsiness, nausea, confusion, and eventually death. Carbon monoxide is a colorless, odorless, tasteless gas which may be present even if you do not see or smell any engine exhaust. Deadly levels of carbon monoxide can collect rapidly, and you can quickly be overcome and unable to save yourself. Also, deadly levels of carbon monoxide can linger for hours or days in enclosed or poorly ventilated areas. If you experience any symptoms of carbon monoxide poisoning, leave the area immediately, get fresh air, and **SEEK MEDICAL TREATMENT**.

- Do not run engine indoors. Even if you try to ventilate engine exhaust with fans or open windows and doors, carbon monoxide can rapidly reach dangerous levels.
- Do not run engine in poorly ventilated or partially enclosed areas such as barns, garages, or carports. If you start a Tractor in one of these, drive it out and close the door as soon as possible. If you drive it into one of these, turn it off as soon as possible.
- Do not run engine outdoors where engine exhaust can be drawn into a building through openings such as windows and doors.

The above list of hazards and overturning risk is not exhaustive.

FORESTRY APPLICATION AND CROP SPRAYING

This Tractor does not have a Falling Objects Protective Structure (FOPS). Do not use the Tractor in forestry application situations where the risk of falling objects may be present.

This Tractor is not equipped for protection against hazardous substances. It does not offer any protection against substances which are harmful to health. Always wear proper personal protective equipment if this Tractor is used for crop spraying or other applications requiring the use of hazardous substances.

LIGHTNING AND POWERLINES

Avoid operating this Tractor when lightning could occur or near powerlines. Rubber tires, rubber handgrips, and a foam seat will not protect a rider from lightning strikes or electrical surges. Always seek safe shelter when lightning is imminent and keep a safe distance from powerlines.

For more information about safety, contact an authorized EGIMOTORS dealer or visit the EGIMOTORS web site at www.polaris.com.

TOWING

WARNING

Towing improperly can alter Tractor handling and may cause loss of control or brake instability.

This *RZR* Tractor can tow Tractor ONLY of equal or lesser size and weight.

When towing a disabled *RZR* Tractor, place the disabled Tractor's transmission in neutral. Do not operate the Tractor faster than 16 km/h (10 MPH) when towing.

IMPORTANT

When using a trailer or machine-mounted trailer, always strictly follow the instructions outlined in the trailer's operator's manual before towing. Never tow trailers unless all respective instructions have been followed.

TOWING A RZR

Towing this Tractor is not recommended. Always transport the Tractor on a trailer or flatbed with all four wheels off the ground. See the Transporting the Tractor section for details.

If towing a disabled Tractor is unavoidable, place the disabled Tractor's transmission in neutral. Tow the shortest distance possible. Do not operate faster than 16km/h

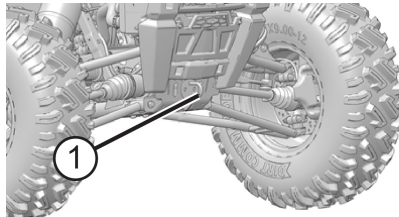

SAFETY

TRANSPORTING THE TRACTOR

WARNING

Cargo and other loose Tractor parts may fly off while transporting this Tractor. Secure or remove all cargo, and inspect the unit for loose parts prior to transport.

If transporting the Tractor in a non-enclosed trailer, then the Tractor must FACE FORWARD, or roof must be removed.

Failure to comply may allow airflow, vibration, or other factors to separate the roof from the Tractor and cause an accident, resulting in serious personal injury or death.

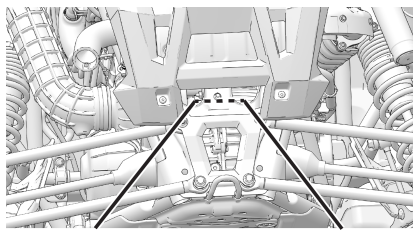
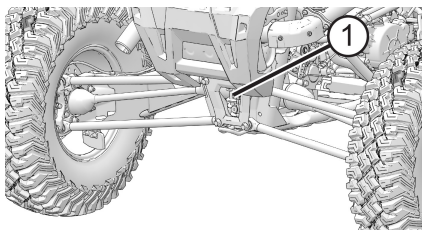

- 1 Two Front Tie-Down Points
- 2 Two Rear Tie-Down Points

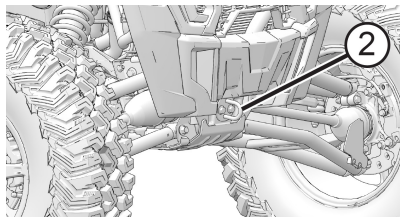

Follow these procedures when transporting the Tractor.

1. Stop the engine. Slowly release the brake pedal and make sure the transmission is in PARK.
2. Engage the park brake.

-
3. Remove the key to prevent loss during transporting. Secure the fuel cap and seats. Ensure that the seats are attached correctly and are not loose.

 **WARNING**

Cargo and other loose Tractor parts may fly off while transporting this Tractor. Secure or remove all cargo, and inspect the unit for loose parts prior to transport.

4. Always tie the frame of the EGIMOTORS Tractor to the transporting unit securely with suitable straps or rope. Do not attach tie straps to the front control arm bolt pockets.

SAFETY

SAFETY LABELS AND LOCATIONS

Warning labels have been placed on the Tractor for your protection. Read and follow the instructions of the labels on the Tractor carefully. If any of the labels depicted in this manual differ from the labels on your Tractor, always read and follow the instructions of the labels *on the Tractor*.

If any label becomes illegible or comes off, contact your EGIMOTORS dealer to purchase a replacement. Replacement *safety* labels are provided by EGIMOTORS at no charge. The part number is printed on the label.

1 General Alerts

2 Load / Passenger /Tire Pressure Alert

3 Clutch Cover Alert

4 Hitch Capacity Alert

5 Intake Alert

6 Radiator Alert

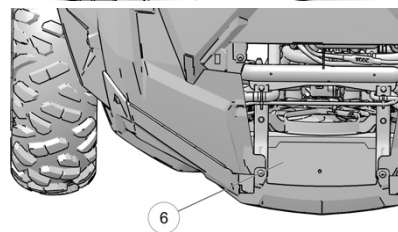
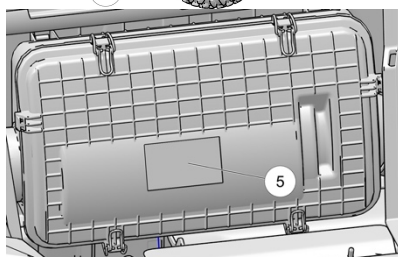
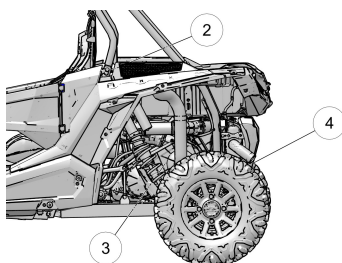
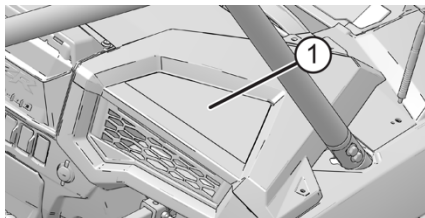
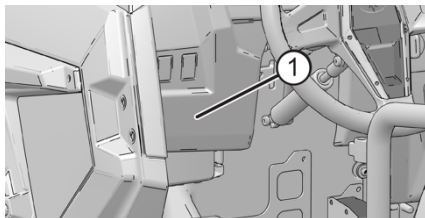
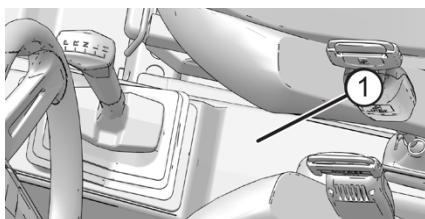













LOAD / PASSENGER / TIRE PRESSURE ALERT

WARNING

Never carry passengers in cargo box. Passengers can be thrown off. This can cause serious injury or death. Read owner's manual. NEVER carry fuel or other flammable liquids on this Tractor. Failure to follow this instruction could lead to serious burn injuries or death.

Part number: 7185229

		RZR XP4 1000	RZR TURBO 4
			
		 120 kPa/1.3 bar	 112 kPa/1.52 bar
		 140 kPa/1.4 bar	 112 kPa/1.52 bar
		 < 136 kg	 < 408 kg
			

GENERAL ALERT

WARNING

Read your owner's manual. Never allow anyone under 18 years of age to operate this Tractor. Never use alcohol or drugs before or while driving or riding. Do not allow operation on public roads (unless designated for off-highway Tractor access). Wear approved helmet, goggles, and protective clothing. Always wear seat belts. Always use the cab nets or doors. Avoid operating in a manner that could result in a rollover. Avoid exhibition driving.

Part number: 7189384

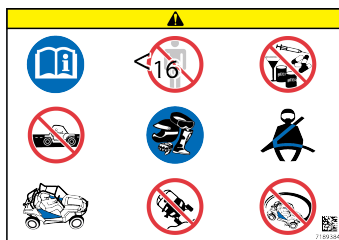

SAFETY

GENERAL ALERT

⚠ WARNING

Always read the owner's manual.
Never allow anyone under 18 years of age to operate this Tractor.
Never use alcohol or drugs before or while driving or riding.
This Tractor is not approved for on-road operation.
Part number: 7183306

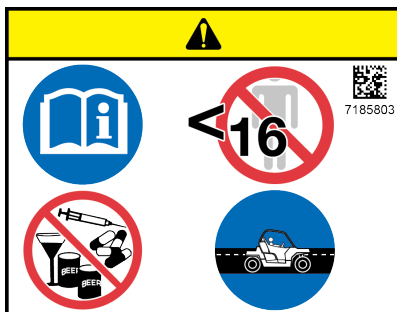

HITCH CAPACITY ALERT

⚠ CAUTION

Always read the owner's manual.
TRAILER MAX WEIGHT: 900kg ON LEVEL GROUND
HITCH MAX VERTICAL WEIGHT: 80 kg
Part number: 7186700

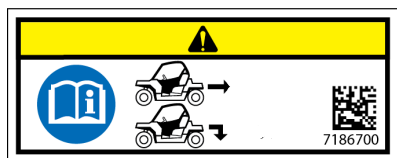

RADIATOR ALERT

⚠ CAUTION

NEVER open the radiator cap when HOT.
Part number: 7300427



GREASING POINTS ALERT

The Greasing Points Alert is located on the cargo box.

CAUTION

Lubricate as recommended. Read owner's manual.

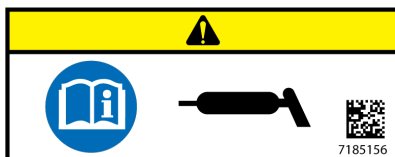

Part number: 7185156

JACKING POINTS ALERT

The Jacking Point Alert decal is located in the cargo box.

CAUTION

Jacking positions are located beneath the Tractor's center points.

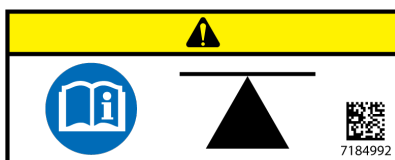

Part number: 7184992

HOT EXHAUST SYSTEM WARNING

WARNING

Exhaust system components are very hot during and after use of the Tractor. Hot components can cause burns and fire. Do not touch hot exhaust system components. Always keep combustible materials away from the exhaust system.

Use caution when traveling through tall grass, especially dry grass and when traveling through muddy conditions. Always inspect the underside of the Tractor and areas near the exhaust system after driving through tall grass, weeds, brush, other tall ground cover, and muddy conditions. Promptly remove any grass, debris or foreign matter clinging to the Tractor and pay particular attention to the exhaust system area.



Part number: 7185151

SAFETY

GENERAL ALERT

⚠ WARNING

Always read the owner's manual.
Never allow anyone under 18 years of age to operate this Tractor.

Never use alcohol or drugs before or while driving or riding.

This Tractor is approved for on-road operation.

Part number: 7185803

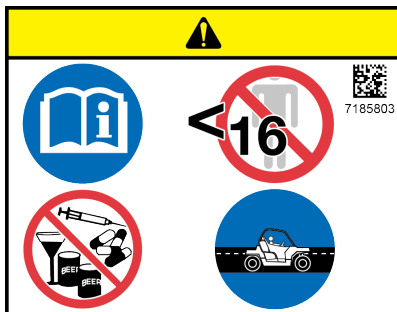

CLUTCH COVER ALERT

The Clutch Cover Alert decal is located on the clutch cover

⚠ CAUTION

Read your owner's manual. Keep body parts away from belt.

Part number: 7181427

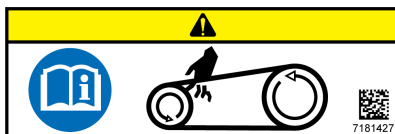

INTAKE ALERT

The Intake Alert Caution label is located on the air intake.

⚠ CAUTION

Use a Egimotors approved air filter. The use of a non-Egimotors approved air filter may cause engine damage. Before installing filter ensure there is no dirt or debris in the clean side of the intake tube. The air filter must be properly seated and the hinges fully inserted when the lid is reinstalled. Please reference your owner's manual for additional information regarding the air filter service.

Part number: 7185975



OWNER'S MANUAL ALERT

The Owner's Manual Alert is located on the console.

Read the owner's manual.

Part number: 7185807



FEATURES AND CONTROLS

COMPONENT LOCATIONS

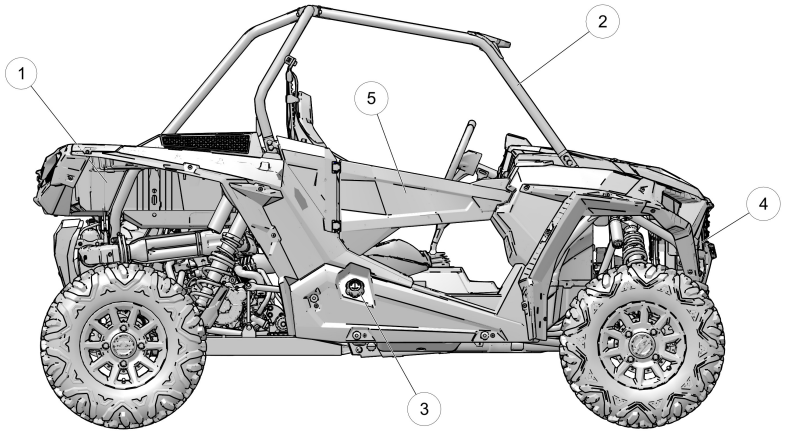

- 1 Cargo Box
- 2 ROPS Frame
- 3 Fuel Tank Cap
- 4 Radiators
- 5 Cab Door
- 6 Tie-Down Points (4 corners)
- 7 Brake Pedal
- 8 Throttle Pedal
- 9 Gear Selector
- 10 Passenger Hand Hold

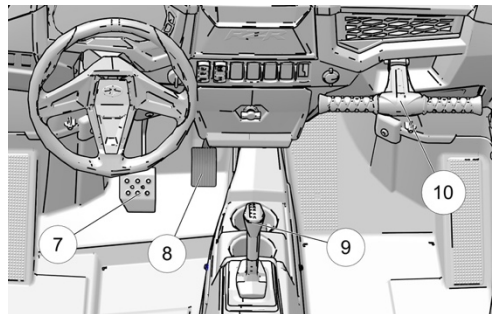
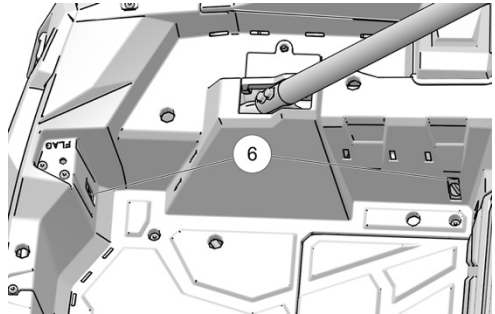

SWITCHES

- 1 Light Switch
- 2 AWD Switch
- 3 Instrument Cluster
- 4 Ignition Switch
- 5 12V Accessory Outlet

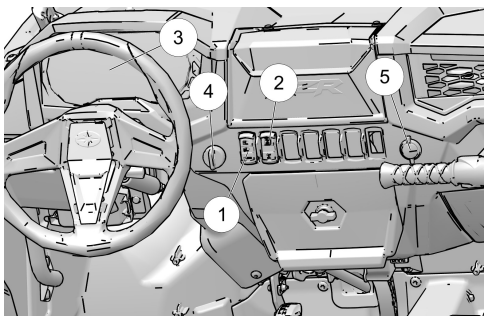

AUXILIARY OUTLETS

The Tractor is equipped with one or more 12-volt accessory outlets. One outlet is on the dash, a second outlet (if equipped) is in the rear passenger area. Use the outlets to power an auxiliary light or other optional accessories. For service, the dash outlet connection is under the dash. The rear outlet connection is under the rear passenger seats.

IGNITION SWITCH

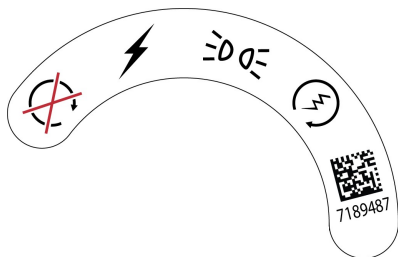

The ignition switch 1 is a four-position, key-operated switch. Use the ignition switch to start the engine. See the Starting the Engine section for starting procedures. The key can be removed from the switch when it is in the OFF position.

FEATURES AND CONTROLS

POSITION	FUNCTION
OFF	The engine is off. Electrical circuits are off, except accessory 12V.
ACCESSORY	The engine is off. Powers the display, terminal block, and front/rear accent lights. Check engine and power steering warning indicators will appear on the display in this mode but will turn off when the Tractor is started if no issues are present.
ON	Electrical circuits are on. Electrical equipment can be used.
START	The Tractor must be in PARK or NEUTRAL before the engine can start. To start the Tractor, press the brake pedal, turn the key to the start position, and then release. The engine will turn over for about 5 seconds or until started.

HEADLIGHT SWITCH

Use the headlight switch to turn the lights on and off and to change the lights from high beam to low beam. The ignition switch must be in the ON position to operate the headlights.

Press the top of the rocker switch toward the dash to place the headlights on high beam *q*. Move the rocker switch to the center position to place the headlights on low beam *w*. Press the bottom of the rocker switch to turn off the headlights.

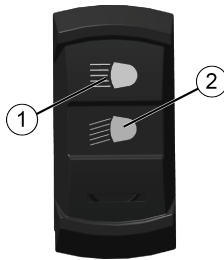

If the headlight switch is ON when the ignition switch is turned off, the lights will remain on for approximately 30 seconds.

FEATURES AND CONTROLS

HORN SWITCH

The horn switch is located on the turn signal lever 1. Press the tip of the turn signal lever inward to sound the horn.



HAZARD LIGHT

The hazard light is controlled by the turn signal lever. To switch the hazard light to ON position, push the lever forward. Pull the lever backward to switch the hazard light to OFF position.

TURN SIGNAL LEVER

Before turning, activate a turn signal to alert others of your intentions. Check turn signal lamps before each ride.

TIP

The key must be in the ON position to activate the turn signals.

Move the turn signal lever downward q to signal a left turn. The left turn signal lamps in the taillight and below the front headlight will flash. The turn signal indicator in the gauge will also flash.

Move the lever upward w to signal a right turn. The right signal lamps and indicator will flash.

Return the lever to the center position to end the signal.

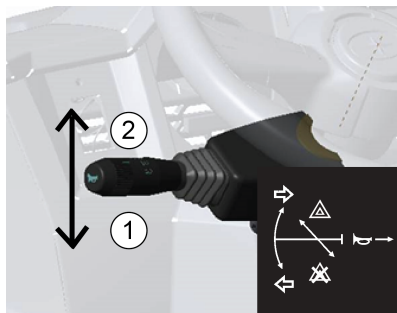

ELECTRONIC POWER STEERING

Electronic power steering engages when the ignition key is turned to the ON position. EPS remains engaged whether the Tractor is moving or idle.

The EPS warning indicator briefly illuminates when the key is turned to the ON position. See the Indicator Lamps section for details.

To conserve battery power, the EPS will shut down 5 minutes after the engine is stopped if the key remains in the ON position. The EPS warning indicator will illuminate to indicate the EPS has shut down.

If the light remains on after starting the engine, the EPS system is inoperative. See your EGIMOTORS dealer, or another qualified person, as soon as possible for repair. Continued operation could result in permanent damage to the EPS unit and increased steering effort.

STEERING WHEEL

The steering wheel can be tilted upward or downward for rider preference. Lift and hold the steering wheel adjustment lever **q** while moving the steering wheel upward or downward. Release the lever when the steering wheel is at the desired position.

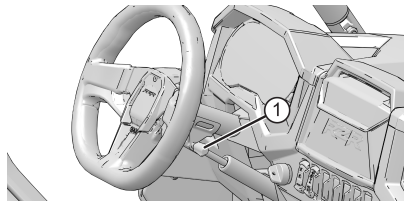

MIRRORS

Use the mirrors to assist in traffic maneuvers. Always check and adjust the mirrors before driving the Tractor.

SEATS

NOTE
TRACTOR MODELS ONLY: These seats are designed for this tractor model. Replacement with different seats is not possible.

Before operating the Tractor, always push down on all seat backs to ensure the latches are secure.

SEAT ADJUSTMENTS

On seats equipped with an adjustment lever under the front edge of the seat, pull the lever to the left. Slide the seat forward or rearward to the desired position. Release the lever. The seat will lock into the new position.

For other seat styles, loosen (do not remove) the four screws located on the seat bottom. Slide the seat forward or rearward to the desired position. Tighten the screws to 5.4 Nm. Do not overtighten.

SEAT REMOVAL

1. Pull up on the seat latch lever located under the rear edge of the seat.
2. Tilt the seat forward.
3. Lift the seat upward to remove it from the Tractor.
4. Reverse this procedure to reinstall the seat. Make sure the seat tabs at the front edge of the seat slide under the seat retainer bar.
5. Press down firmly at the rear of the seat to engage the rear latch.

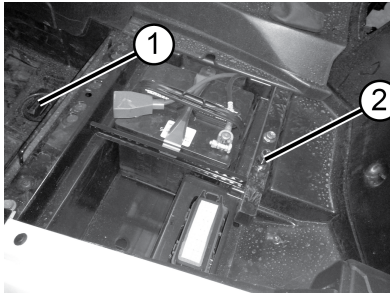

- 1 Front Seat Retainer
2 Seat Latch

PASSENGER HAND HOLD

Always adjust the hand hold to a comfortable position for your passenger before operating. Make sure the adjustment pin and retainer are securely installed after making adjustments.

1. Remove the retainer q from the end of the adjustment pin w.
2. Remove the pin from the post.
3. Slide the post inward or outward to the desired position.
4. Reinstall the pin through the post mounting hole e, adapter bushing hole r, both post adjustment holes t, and lastly through the remaining bushing hole and post mounting hole.

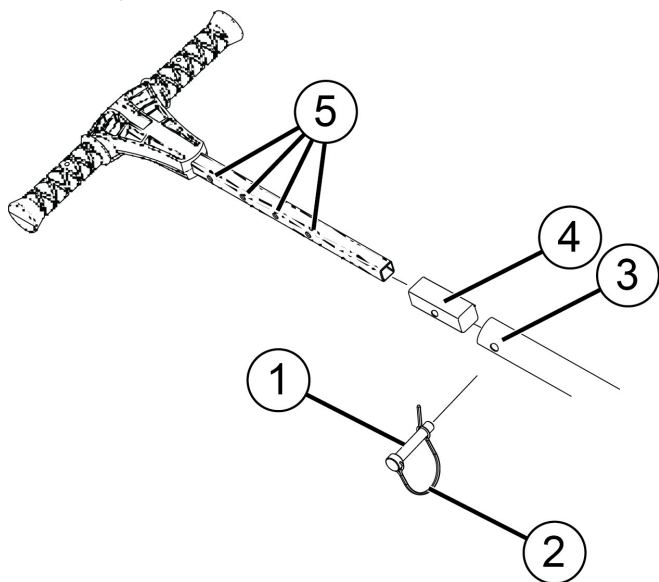

5. Reinstall the retainer to the pin.

HOOD

Remove the hood to access the radiator pressure cap **q** and pressure tank **w**.

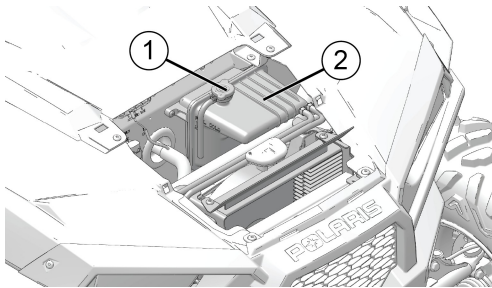

1. Turn the hood fasteners **e** 1/4 turn.

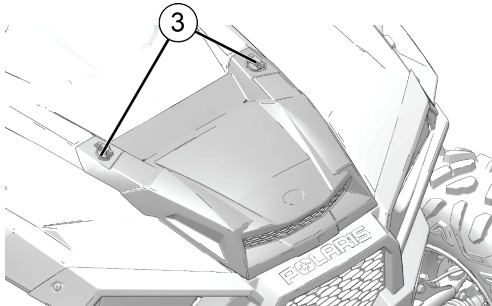

2. Grasp the upper hood edge and pull upward to disengage the fasteners.
3. Pivot the hood forward and lift upward to disengage the lower hood hooks.
4. Lift the hood away from the Tractor.

FUEL CAP

The fuel tank filler cap 1 is located on the right-hand side of the Tractor near the passenger seat. To close, tighten the fuel cap until it clicks twice.

Use Fuel Type as mentioned here below.

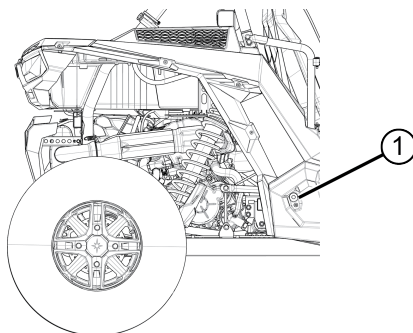
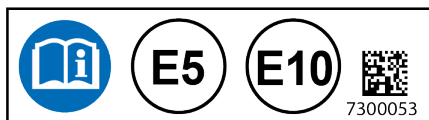

SERVICE ACCESS PANELS

ENGINE ACCESS PANEL

The engine access panel is located behind the seats on the frame of the Tractor. Remove the seats and remove the access panel to reach serviceable engine components.

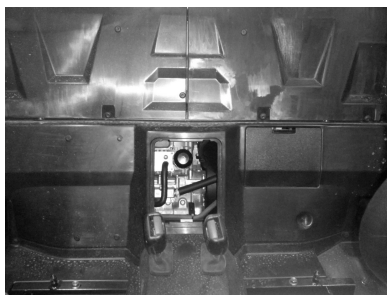

CARGO BOX ACCESS PANEL

The cargo box access panel is located on the floor of the cargo box. Remove the panel to access the engine oil fill cap, spark plugs and air filter.

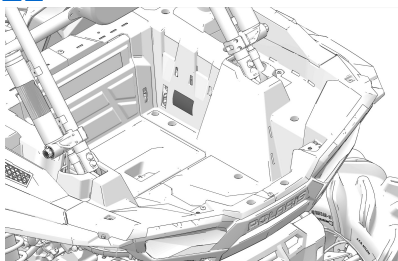

CARGO BOX ACCESS PANEL

The cargo box access panel is located on the floor of the cargo box. Remove the panel to access the engine oil fill cap, spark plugs and air filter.

CAB DOORS

Riding in this Tractor without closed and latched cab doors increases the risk of serious injury or death in the event of an accident or rollover. Always make sure all cab doors are closed and latched while riding in this Tractor. Cab doors are NOT intended to be used as arm rests. *Keep hands and feet inside the Tractor at all times.*

SEAT BELTS

This EGIMOTORS Tractor is equipped with seat belts for all riders. Always make sure the seat belts are secured for the operator and all passengers before riding. The driver's seat belt is equipped with a seat belt interlock. Tractor speed will be limited to 15 mph (24 km/h) if the seat belt is not secured.

3-POINT SEAT BELT

To wear the 3-point seat belt properly, follow this procedure:

1. Pull the seat belt latch downward and across your chest toward the buckle at the inner edge of the seat. The belt should fit snugly across your hips and diagonally across your chest. Make sure the belt is not twisted.
2. Push the latch plate into the buckle until it clicks. Pull up on the strap to tighten.
3. Press the red release latch on the buckle to release the seat belt.

SEAT BELT INSPECTION

Inspect all seat belts for proper operation before each use of the Tractor.

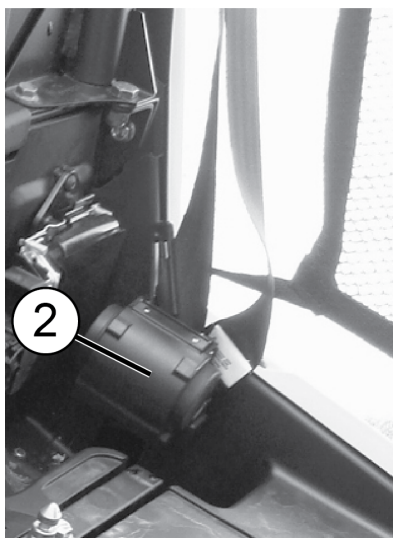

1. Push the latch plate into the buckle until it clicks. The latch plate must slide smoothly into the buckle. A click indicates that it's securely latched.
2. Push the red release latch in the middle of the buckle to make sure it releases freely.
3. Pull each seat belt completely out and inspect the full length for any damage, including cuts, wear, fraying or stiffness. If any damage is found, or if the seat belt does not operate properly, have the seat belt system checked and/or replaced by an authorized EGIMOTORS dealer or other authorized person.
4. To clean dirt or debris from the seat belts, sponge the straps with mild soap and water. Do not use bleach, dye or household detergents. Rinse the entire length of the belt webbing. Use a garden hose to flush out the latch and retractor housings regularly.

GEAR SELECTOR

To change gears, stop the Tractor, and with the engine idling, move the lever q to the desired gear. Do not attempt to shift gears with engine speed above idle or while the Tractor is moving.

- P: Park
- R: Reverse
- N: Neutral
- L: Low Gear
- H: High Gear

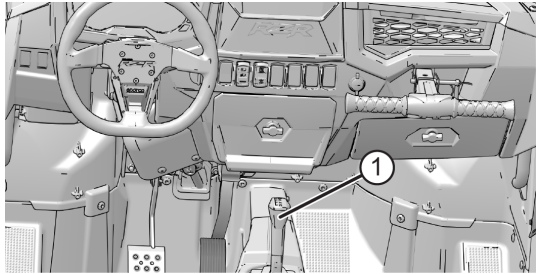

TIP

Maintaining shift linkage adjustment is important to assure proper transmission function. Your EGIMOTORS dealer or qualified person can assist in resolving any shifting problems.

NOTICE

Do not attempt to shift the transmission while the Tractor is moving or damage to the transmission could result. Always shift when the Tractor is stationary and the engine is at idle.

USING LOW RANGE

Always shift into low gear for any of the following conditions:

- Operating in rough terrain or over obstacles
- Loading the Tractor onto a trailer
- Towing heavy loads

BRAKE AND THROTTLE PEDALS

BRAKE PEDAL

Depress the brake pedal 1 to slow or stop the Tractor. Apply the brakes while starting the engine.

THROTTLE PEDAL

Push the throttle pedal 2 down to increase engine speed. Spring pressure returns the pedal to the rest position when released. Always check that the throttle pedal returns normally before starting the engine.

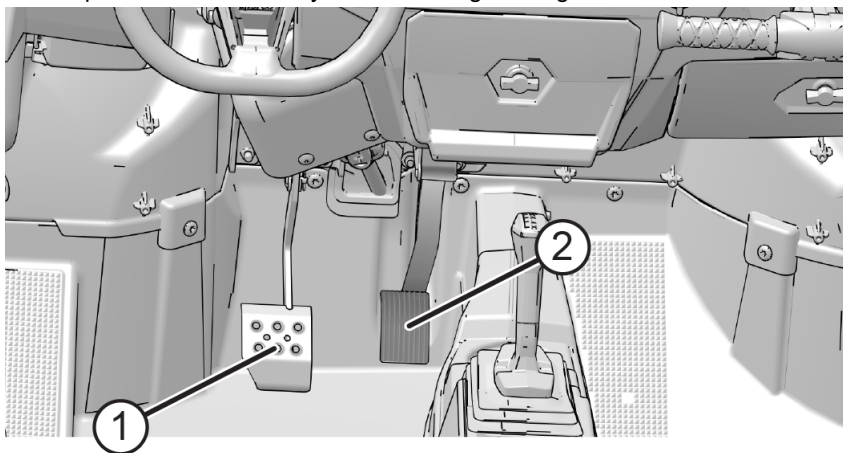

TIP

If the throttle pedal and brake pedal are applied simultaneously, engine power may be limited.

AUXILIARY BRAKE PEDAL

An Auxiliary brake pedal is available
The red pedal is the Auxiliary pedal located above the main one

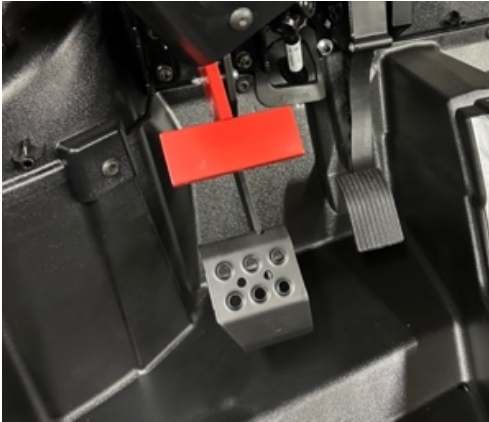

HITCHES

WARNING

Whenever the Tractor is towing, always stay clear of the area between the Tractor and the towed object. Occupying this area while towing can result in serious injury or death.

REAR HITCH

NOTICE

After 1000 km of use, tighten the bolt holding the trailer ball to the hitch to 445 N-m.

Use the rear hitch for towing a trailer. See the Hauling Cargo section for details and procedures.

The values given below pertain to factory-installed hitches and are provided for informational purposes only.

IMPORTANT

For Tractor-specific trailering values, see the Specifications chapter. The Tractor-specific values take precedent if they are lower than the component values shown below.

REAR HITCH COMPONENT SPECIFICATIONS

Maximum Vertical Load	85 kg
Maximum Towable Mass Braked	900 kg

REAR HITCH CERTIFICATION LABEL

The hitch certification label is located on the hitch bar.

HITCH REMOVAL / INSTALLATION

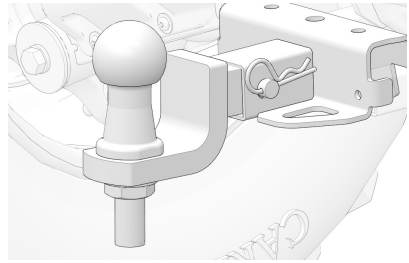
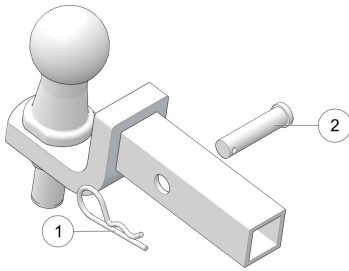

1. To remove the hitch (if equipped), remove the cotter pin **q** and hitch pin **w**. Remove the hitch, then reinstall the hitch pin **w** and secure the cotter pin **q**.
2. To install the hitch, remove the cotter pin **q** from the hitch pin and remove the hitch pin **w**.
3. Install the hitch to the receiver.
4. Reinstall the hitch pin (from the left side of the hitch) through the bore of both the receiver and the hitch.
5. Reinstall the cotter pin. Make sure the hitch assembly is secure at that the cotter pin is properly engaged over the hitch pin.

7-WAY TRAILER CONNECTOR

The 7-way trailer connector (if equipped) **q** installed on your Tractor meets the requirements of European standard ISO 1724.

This connector uses all 7 pins on newer model trailers. An older model trailer may not be compatible with this connector.

Improper electrical wiring changes can result in damage to both Tractor and trailer components. When in doubt about your trailer connection, please contact a qualified tow-bar specialist for assistance.

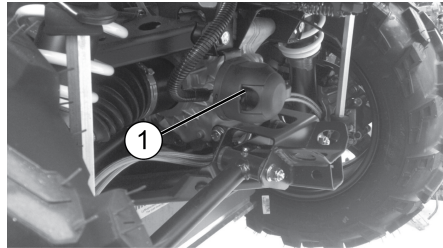

ROLLOVER PROTECTIVE STRUCTURE (ROPS)

The Rollover Protective Structure (ROPS) on this Tractor meets rollover performance requirements. Always have your authorized EGIMOTORS dealer thoroughly inspect the ROPS if it ever becomes damaged in any way.

No device can assure occupant protection in the event of a rollover. When used with seat belts and cab nets or doors, the ROPS helps prevent occupants from being ejected from the Tractor. Always follow all safe operating practices outlined in this manual to avoid Tractor rollover.

WARNING

Tractor rollover could cause severe injury or death. Always avoid operating in a manner that could result in Tractor rollover.

ALL WHEEL DRIVE (AWD) SYSTEM

The All Wheel Drive system is controlled by the AWD switch. The switch has two positions, AWD (4x4) and 2WD (2x4). The switch on models equipped with a lockable differential has a third position for unlocking the differential. When unlocked, only one rear wheel is a drive wheel

When the switch is on 2X4, the Tractor is in two-wheel drive at all times. When the switch is on AWD, the Tractor is in all wheel drive and the 4X4 indicator in the instrument cluster will be on.

When in AWD, the demand drive unit will automatically engage any time the rear wheels lose traction. When the rear wheels regain traction, the demand drive unit will automatically disengage.

There is no limit to the length of time the Tractor may remain in AWD.

ENGAGING AWD

The AWD switch may be turned on or off while the Tractor is moving. Initially, the Tractor's electronic system will not enable the AWD until the engine RPM is below 3100. Once enabled, the AWD remains enabled until the AWD switch is turned off. If the switch is turned off while the demand drive unit is moving, it will not disengage until the rear wheels regain traction.

Engage the AWD switch before getting into conditions where front wheel drive may be needed. If the rear wheels are spinning, release the throttle before switching to AWD.

NOTICE

Switching to AWD while the rear wheels are spinning or slipping may cause severe drive shaft and gearcase damage. Always switch to AWD while the rear wheels have traction or are at rest.

DISENGAGING AWD

Move the AWD switch to the center or bottom position to disengage AWD. If the switch is turned off while the front hubs are driving, they will not release until the rear wheels regain traction.

In some situations, the front gearcase may remain locked after turning the AWD switch off. If this occurs, you may notice increased steering effort and some Tractor speed restriction. Perform the following procedure to unlock the front gearcase.

1. Stop the Tractor.
2. Operate in reverse for at least 10 ft (3 m).
3. Stop completely.
4. Shift into low gear and drive forward.
5. If the front gearcase remains locked after following these instructions, see your dealer for service.

LOCKING/UNLOCKING THE DIFFERENTIAL

NOTICE

Damage to the differential can occur if it is engaged while the Tractor is traveling at high speeds or while the rear wheels are spinning. Slow the Tractor to nearly stopped before engaging the differential.

Locking the differential in slippery or low traction conditions helps improve traction. Move the rocker switch to the center position (2WD) to lock the differential and operate in rear wheel drive.

DRIVELINE MODE SWITCH

The Driveline Mode Switch:

- 1 All Wheel Drive (AWD)
- 2 Two Wheel Drive (2WD)

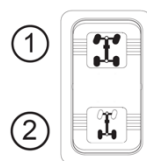

Press the bottom of the switch to unlock the differential and allow the rear drive wheels to operate independently. This mode of operation is well suited to turf driving .

INSTRUMENT CLUSTER

NOTICE

High water pressure may damage components. Wash the Tractor by hand or with a garden hose using mild soap. Certain products, including insect repellents and chemicals, will damage the speedometer lens and other plastic surfaces. Do not use alcohol to clean the instrument cluster. Do not allow insect sprays to contact the lens. Immediately clean off any gasoline that splashes on the instrument cluster.

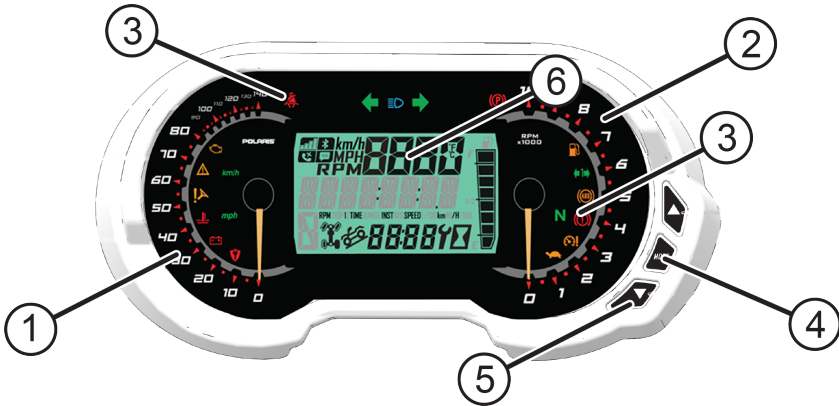

- 1 Speedometer
- 2 Tachometer
- 3 Indicator Lamps

- 4 Mode Button
- 5 Toggle Buttons
- 6 Rider Information Center

SPEEDOMETER

The speedometer displays Tractor speed in either miles per hour (MPH) or kilometers per hour (km/h).

TACHOMETER

The tachometer displays engine speed in revolutions per minute (RPM).

MODE BUTTON

Press and hold the MODE button  to enter or exit the settings menu. Press and release the MODE button to cycle through Area 1 modes and to select an item.

FEATURES AND CONTROLS





TOGGLE BUTTONS

Press and release either toggle button to cycle through the options menu or Area 2 modes. Press and hold either toggle button to reset an item.



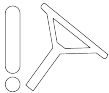

TIP

With the ignition key off, pressing the MODE button or either toggle button will power up the Rider Information Center for 10 seconds to allow viewing of the odometer and the clock.

INDICATOR LAMPS

LAMP	INDICATES	CONDITION
MPH	Tractor Speed	When standard mode is selected, speed displays in miles per hour.
km/h		When metric mode is selected, speed displays in kilometers per hour.
	Over Temperature	This lamp illuminates to indicate an overheated engine. If the indicator flashes, the overheating condition remains, and the system will automatically reduce engine power.
	Electric Power Steering (EPS) Warning (if equipped)	This indicator illuminates briefly when the key is turned to the ON position. If the light remains on, the EPS system is inoperative. See your EGIMOTORS dealer, or other qualified person, as soon as possible for repair. Continued operation could result in permanent damage to the EPS unit and increased steering effort.
N	Neutral	This lamp illuminates when the transmission is in neutral and the ignition key is in the ON position.
	High Beam	This lamp illuminates when the headlamp switch is set to high beam.
	Helmet/Seat Belt	This lamp is a reminder to the operator to ensure all riders are wearing helmets and seat belts before operating. The driver's seat belt is equipped with a seat belt interlock. Tractor speed will be limited to 15 MPH (24 km/h) if the seat belt is not secured.
	Check Engine	This indicator appears if an Electronic Fuel Injection (EFI) related fault occurs. Do not operate the Tractor if this warning appears. Serious engine damage could result. Your dealer can assist.

FEATURES AND CONTROLS

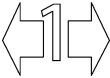
LAMP	INDICATES	CONDITION
	Check Battery	This warning usually indicates that the Tractor is operating at an RPM too low to keep the battery charged. It may also occur when the engine is at idle and high electrical load (lights, cooling fan, accessories) is applied. Drive at a higher RPM or recharge the battery to clear the warning.
	Low Fuel	This lamp illuminates when fuel level in the fuel tank is low.
	Direction Indicators	Direction indicators flash when a turn signal is active. Both indicators flash when the hazard signal is active.
	Brake Failure Alarm	Lamp illuminates when Brake System (if Brake Failure Alarm is equipped) detects low pressure in brake hydraulic system.
	Park Brake	Lamp illuminates when the Park Brake is applied.
	Trailer Indicator	The Turn Trailer Indicator is illuminating when the trailer turn signals are active.

RIDER INFORMATION CENTER

q	Gear Indicator	This indicator displays gear shifter position. H = High Gear L = Low Gear N = Neutral R = Reverse Gear P = Park – = Gear Signal Error (or shifter between gears)
w	Driveline Indicator	This indicator shows whether 2X4, Turf, or AWD is active.
e	Service Indicator	A flashing wrench symbol alerts the operator that the preset service interval has been reached. Your EGIMOTORS dealer, or other qualified person, can provide scheduled maintenance. See page 66 for resetting instructions.
r	Fuel Gauge	The segments of the fuel gauge show the level of fuel in the fuel tank. When the last segment clears, a low fuel warning is activated. The outline of the fuel display will flash. Refuel immediately.

The rider information center is located in the instrument cluster. All segments will light up for one second at start-up. If the instrument cluster fails to illuminate, a battery over-voltage may have occurred and the instrument cluster may have shut off to protect the electronic speedometer. If this occurs, your EGIMOTORS dealer, or other qualified person, can provide proper diagnosis.

The information center is set to display standard units of measurement and a 12-hour clock at the factory. To change to metric and/or a 24-hour clock hold the mode button and cycle to the clock menu. Use the directional arrows to change the clock settings.

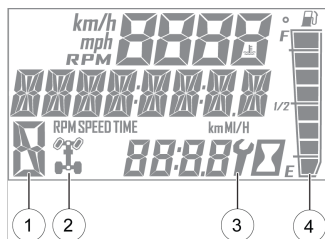

MODE INFORMATION DISPLAYS

The rider information center contains three areas that display mode information.

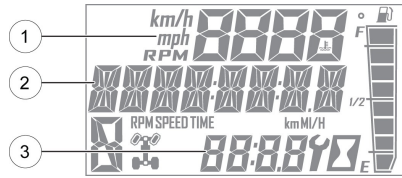

q Area 1 Modes	Description
Engine Temperature	Temperature of engine coolant
Tractor Speed	Speed of Tractor
Tachometer	Engine speed (RPM)
w Area 2 Modes	Description
Odometer	The odometer records and displays the distance traveled by the Tractor.
Trip Meters (T1/T2)	A trip meter records the distance traveled by the Tractor if reset before each trip. To reset, see page 65.
Engine Hours	Total hours of engine operation since manufacture
Service Hours	A flashing wrench symbol indicates that the preset service interval has been reached. To reset, see page 66.
Trip Time	Time length of Tractor operation since mode was last reset
e Area 3 Modes	Description
Clock	The clock displays time in a 12-hour or 24-hour format. To reset, see page 64.

ACCESSING MENUS AND OPTIONS

GAUGE SETTINGS MENU

Press and release the MODE button to cycle through the Area 1 modes until the desired default mode displays. See the Mode Information Displays section for details.

Press and hold the MODE button to enter the settings menu.

The OPTIONS screen will display for a few seconds.

1. Press and release either toggle button to cycle to the desired option.
2. Press MODE to select the option.
3. Press either toggle button to cycle to the desired setting.
4. Press MODE to save and exit to the settings menu.
5. Press and hold the MODE button to exit the settings menu.

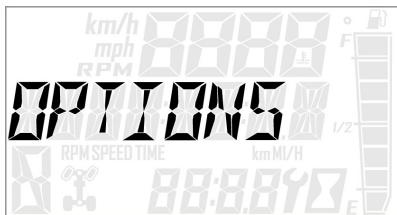

BACKLIGHT COLOR

The information center backlight can be set to either blue or red.

1. Press and hold the MODE button to enter the settings menu.
2. Press either toggle button to cycle to the "BL COLOR" option. Press MODE to select.
3. Press either toggle button to cycle to the desired setting.
4. Press MODE to save and exit to the settings menu,



BACKLIGHT BRIGHTNESS

The information center backlight can be set to either blue or red.

1. Press and hold the MODE button to enter the settings menu.
2. Press either toggle button to cycle to the "BL LEVEL" option. Press MODE to select.
3. Press "UP" button to increase brightness. Press "DOWN" button to decrease brightness.
4. Press MODE to select and exit to the settings menu.



CLOCK

The clock must be reset any time the battery has been disconnected or discharged.

1. Press and hold the MODE button to enter the settings menu.
2. Press either toggle button to cycle to the "CLOCK" option. Press MODE to select.
3. Press either toggle button to cycle to the desired setting (12H or 24H). Press MODE to select.
4. Press either toggle button to change each segment of the clock. Press MODE to accept a change and advance to the next segment.



DISPLAY UNITS (STANDARD/METRIC)



1. Press and hold the MODE button to enter the settings menu.
2. Press either toggle button to cycle to the desired "UNITS" option (distance, temperature or volume). Press MODE to select.
3. Press either toggle button to cycle to the desired setting.
4. Press MODE to save and exit to the settings menu.

TRIP METER

Use a trip meter to track the distance traveled during a specific trip or period of time. Reset the meter to zero before traveling.

1. Press either toggle button to cycle to the desired trip meter option (T1 or T2).
2. Press and hold either toggle button until the meter resets to zero.

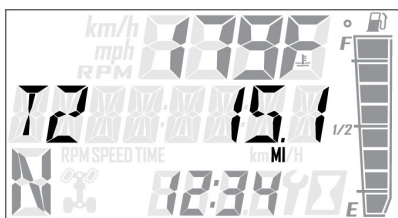

TRIP TIME

Use a trip time meter to track the travel time during a specific trip. Reset the meter to zero before traveling.

1. Press either toggle button to cycle to the trip time option (TT).
2. Press and hold either toggle button until the meter resets to zero.



PROGRAMMABLE SERVICE INTERVAL

The service interval counter is programmed to 25 hours at the factory. As hours of engine operation increase, the counter decreases. The wrench icon will flash for about 10 seconds when the counter reaches zero (0), and each time the key is turned on thereafter, until the counter is reset.

When this feature is enabled, it provides a convenient reminder to perform routine maintenance. Refer to the Periodic Maintenance Chart for recommended service intervals.

Use the following procedure to reset or change the service interval.

1. Press and hold the MODE button to enter the settings menu.
2. Press either toggle button to cycle to the "Service Hours" option. Press MODE to select.
3. Press MODE to reset the existing value and exit, or press either toggle button to change the value. Press MODE to save and exit to the settings menu.



ENGINE ERROR CODES

The error screen displays only when the CHECK ENGINE indicator is on or when it goes on and off during one ignition cycle. Error codes are not stored. When the key is turned OFF, the code and message is lost, but will reappear if the fault reoccurs after restarting the engine.

If the CHECK ENGINE lamp or the EPS lamp illuminates, retrieve the active error codes from the display.

- q Failure Mode Indicator (FMI)
- w Suspect Parameter Number (SPN)
- e Code Count

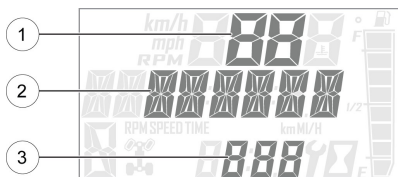

1. Press and hold the MODE button to enter the settings menu.
2. Press either toggle button to cycle to the “DIAGCODE” option. Press MODE to select.
3. More than one diagnostic code may be present. Press the toggle UP button to see if more codes are present. Press MODE to select a code.

NOTICE

If the displayed code is an engine fault code, the CHECK ENGINE lamp will blink. If the displayed code is an EPS fault code, the EPS lamp will blink.

4. Record the three (3) numbers displayed.
5. Press MODE to exit to the settings menu.

OPERATION

TRACTOR BREAK-IN

ENGINE AND DRIVETRAIN BREAK-IN

1. Fill the fuel tank with the recommended fuel. See the Refueling section for details. Always exercise extreme caution whenever handling fuel.
2. Check the oil level. See the Oil Check section for details. Add the recommended oil as needed to maintain the oil level in the safe operating range.
3. Avoid aggressive use of the brakes.
4. Vary throttle positions. Do not operate at sustained idle.
5. Perform regular checks on fluid levels, controls and areas outlined on the daily pre-ride inspection checklist.
6. Carry only light loads.
7. During the break-in period, change both the oil and the filter at 25 hours, one month, or 500 miles, whichever comes first.
8. Check fluid levels of transmission and all gearcases after the first 25 hours of operation and every 50 hours thereafter.

BRAKE SYSTEM BREAK-IN

Apply only moderate braking force for the first 50 stops. Aggressive or overly forceful braking when the brake system is new could damage brake pads and rotors.

OPERATION

PVT BREAK-IN (CLUTCHES / BELT)

A proper break-in of the clutches and drive belt will ensure a longer life and better performance. If a belt fails, always clean any debris from the duct and from the engine compartment.

STANDARD BREAK-IN

Drive at slower speeds for the first 50 miles (80 km) of operation. Carry only light loads. Avoid aggressive acceleration, high-speed operation and prolonged operation at a specific RPM during this period.

SAND / DUNE BREAK-IN

Drive in low gear for the first 5 miles (8 km) of operation. Avoid prolonged low speed operation at high throttle. Avoid aggressive acceleration, high-speed operation and prolonged operation at a specific RPM during this period.

BELT LIFE

To extend belt life, use low gear in the following conditions:

- When hauling or towing heavy cargo
- When consistently operating at speeds less than 35 MPH (56 km/h) in hard-pulling terrain, such as mud, rocks or sand/dune environments.

OPERATING GUIDELINES

STARTING THE ENGINE

NOTICE

Operating the Tractor immediately after starting could cause engine damage. Allow the engine to warm up for several minutes before operating the Tractor.

1. Position the Tractor on a level surface outdoors or in a well-ventilated area.
2. Sit in the driver's seat and fasten the seat belt. Always make sure all cab doors are closed and latched when riding in this Tractor.
3. Place the transmission in PARK.
4. Apply the brakes. Do not press the throttle pedal while starting the engine.
5. Turn the ignition key past the ON/RUN position and release immediately to START. The engine will turn over for a maximum five seconds until the Tractor has started.
6. If the engine does not start within five seconds, return the ignition switch to the OFF position and wait five seconds. Repeat steps 5 and 6 until the engine starts.
7. After starting the engine, wait 10 seconds before applying throttle.

BRAKING

1. Release the throttle pedal completely.

TIP

When the throttle pedal is released completely and engine speed slows to near idle, the Tractor has no engine braking.

2. Press on the brake pedal evenly and firmly.
3. Practice starting and stopping (using the brakes) until you're familiar with the controls.

OPERATION

DRIVING IN REVERSE



Before shifting into reverse, use extra care to make sure the area is clear of people or obstacles. When it's safe to proceed, back slowly.

Follow these precautions when operating in reverse:

1. Always check for obstacles or people behind the Tractor.
2. Apply the throttle *lightly*. Never open the throttle suddenly.
3. Back slowly.
4. Apply the brakes *lightly* for stopping.
5. Avoid making sharp turns.

STOPPING THE ENGINE AND PARKING THE TRACTOR



When leaving the Tractor on an incline is unavoidable, use extra care. Tractor rollaway can cause serious injury or death. This Tractor can roll whenever the gear selector is not in the PARK (P) position. Always shift to PARK (P) when stopping the engine or leaving the Tractor. If leaving the Tractor unattended, block the rear wheels on the downhill side and keep children, pets, and others away from the gear selector.

To park the Tractor:

1. Stop the Tractor on a level surface.
2. Place the transmission in PARK (P). This Tractor can roll whenever the transmission is not in the PARK (P) position.
3. Stop the engine.
4. Engage the park brake (if equipped).
5. Remove the ignition key to prevent unauthorized use.

FUEL

WARNING

Gasoline and gasoline vapor is highly flammable and explosive. Refuel outdoors or in a well ventilated area free of any source of flame or sparks, including pilot lights from water heaters, furnaces, or clothes dryers. To avoid fires and explosions, follow these precautions when refueling.

- Do not smoke.
- Wipe up any spilled fuel.

WARNING

Gasoline is poisonous. To avoid injury or death, avoid contact with gasoline and follow these precautions:

- Never attempt to siphon gasoline by mouth.
- If gasoline is ingested, contacts eyes, or gasoline vapor is inhaled, immediately seek medical attention.
- If gasoline contacts skin, wash with soap and water.
- If gasoline contacts clothes, change out of them.

REFUELING

The fuel tank filler cap is located on the right side of the Tractor near the passenger seat.

The fuel symbol and the last fuel bar on the Instrument Cluster will blink when the fuel level reaches 1/8th tank. There will be approximately 2 gallons (8 L) of fuel remaining. Refuel as soon as possible. *Do not allow the Tractor to run out of fuel.*

To refuel:

1. Place the transmission into Park on a level surface.
2. Turn off the engine.
3. Make sure no one is inside the Tractor.
4. Fill with fuel, leaving the tank neck empty.
5. Securely close fuel cap.

OPERATION

WARNING

Gasoline can expand while inside the tank. To avoid fires and explosions, do not overfill the tank. Allow room for gasoline to expand inside the tank by leaving the tank neck empty.

NOTICE

Damage to the fuel pump will occur if the Tractor is operated with an empty fuel tank. Do not allow the Tractor to run out of fuel. Always refuel when the level is low.

NOTICE

Operating with obstructed fuel systems will result in serious engine damage. Perform maintenance as recommended.

NOTICE

Prolonged exposure to petroleum based products may damage paint. Always protect painted surfaces when handling fuel.

EMISSION CONTROL SYSTEMS

NOISE EMISSION CONTROL SYSTEM

Do not modify the engine, intake or exhaust components, as doing so may affect compliance with governmental noise level requirements.

CRANKCASE EMISSION CONTROL SYSTEM

This engine is equipped with a closed crankcase system. Blow-by gases are forced back to the combustion chamber by the intake system. All exhaust gases exit through the exhaust system.

EXHAUST EMISSION CONTROL SYSTEM

Exhaust emissions are controlled by engine design. An electronic fuel injection (EFI) system controls fuel delivery. The engine and EFI components are set at the factory for optimal performance and are not adjustable.

The emissions label is located on the left front frame of the Tractor.

ELECTROMAGNETIC INTERFERENCE

This Tractor complies with the EMC requirements of EU regulation No. 2015/208 Annex XV.

Non-ionizing Radiation: This Tractor emits some electromagnetic energy. People with active or non-active implantable medical devices (such as heart monitoring or controlling devices) should review the limitations of their device and the applicable electromagnetic standards and directives that apply to this Tractor.

MAINTENANCE

ELEVATING THE TRACTOR FOR SERVICE

Some service procedures require that the Tractor be elevated. Before proceeding, remember to:

- Always position the Tractor on a firm, level surface before elevating.
- Only use an appropriate sized lift or jack.
- Refrain from positioning a jack or jack stand under any components other than the Tractor frame.
- Refrain from allowing the Tractor to remain elevated on a floor jack for an extended period of time.

PLACING ONTO JACK STANDS

1. Place the floor jack directly beneath the center of the Tractor (either front or rear).
2. This Tractor is not equipped with dedicated jacking points. Make sure that the floor jack only makes contact with the Tractor *frame* only while lifting.
3. After Tractor is elevated to desired height, place jack stands under the Tractor *frame* on both sides of the floor jack, then lower the Tractor until the jack stands come into contact with the Tractor *frame*.

BOARDING AND EXITING THE TRACTOR

- Never try to climb onto or exit the Tractor while it is moving.
- Do not exit the Tractor by jumping off.
- Always face the Tractor when boarding or exiting.
- Do not grab controls as hand supports. This may cause inadvertent machine movements.
- Always keep Tractor steps and flooring clean to prevent slippery conditions.

MAINTENANCE

PERIODIC MAINTENANCE CHART

Any qualified repair shop or person may maintain, replace or repair the emission control devices or systems on your Tractor. An authorized EGIMOTORS dealer can perform any service that may be necessary for your Tractor. EGIMOTORS also recommends EGIMOTORS parts for emissions-related service, however equivalent parts can be used.

It is a potential violation of the Clean Air Act if a part supplied by an aftermarket parts manufacturer reduces the effectiveness of the Tractor's emission controls. Tampering with emission controls is prohibited by federal law.

Owners are responsible for performing the scheduled maintenance identified in this owner's manual.

Careful periodic maintenance will help keep your Tractor in the safest, most reliable condition. Inspection, adjustment and lubrication of important components are explained in the periodic maintenance chart.

Inspect, clean, lubricate, adjust and replace parts as necessary. When inspection reveals the need for replacement parts, genuine EGIMOTORS parts are available from your EGIMOTORS dealer. Equivalent parts may be used for emissions-related service.

Service and adjustments are important for proper Tractor operation. If you're not familiar with safe service and adjustment procedures, a qualified dealer can perform these operations.

Tractor subjected to heavy or severe use patterns must be inspected and serviced more frequently.

SEVERE USE DEFINITION

- Frequent immersion in mud, water or sand
- Racing or race-style high RPM use
- Prolonged low speed, heavy load operation
- Extended idle
- Frequent short trip operation in cold weather (engine frequently does not operate long enough to reach full operating temperature)

Pay special attention to the oil level. A rise in oil level during cold weather can indicate contaminants collecting in the oil sump or crankcase. Change oil immediately if the oil level begins to rise. Monitor the oil level, and if it continues to rise, discontinue use and determine the cause. Your EGIMOTORS dealer or other authorized person can assist.

MAINTENANCE CHART TABLES

The maintenance interval charts outline required maintenance and inspection based on Tractor hours / miles. Each table states the number of hours / miles that service is required on the Tractor. Some items or components may need to be serviced more often due to severe use, such as operation in water or under severe loads. When the Tractor goes beyond 500 hours / 5000 miles, return to the 25 hours / 250 mile chart and start the interval process over.

25 HOUR / 250 MILE (400 KM) SERVICE

ITEM		REMARKS
XU / D	Brake Pads / Parking Brake Pads (INT'L)	Inspect pad wear
	Fuel System	Turn key on to pressurize fuel pump; check lines / fittings for leaks and abrasion
XU / D	Parking Brake Cable Adjustment (INT'L)	Inspect; adjust tension if necessary
XU	Engine Breather	Inspect; clean
	Battery	Check terminals; clean; test
XU	Engine Oil & Filter Change (Break-In)	Perform a break-in oil and filter change at 25 hours or one month; perform every 50 hours or 6 months thereafter
XU	Front Gearcase Lubricant	Initial fluid level inspection; add lubricant if needed
XU	Transmission Lubricant (AGL)	Initial fluid level inspection; add lubricant if needed

XU - Perform these procedures more often for Tractor subjected to severe use. D

- Have an authorized Egimotors dealer perform these services.

MAINTENANCE

50 HOUR / 500 MILE (800 KM) SERVICE

ITEM		REMARKS
XU /D	Brake Pads / Parking Brake Pads (INT'L)	Inspect pad wear; replace if worn beyond service limit
	Fuel System	Turn key on to pressurize fuel pump; check lines / fittings for leaks and abrasion
XU /D	Parking Brake Cable Adjustment (INT'L)	Inspect; adjust tension if necessary
XU	Engine Breather	Inspect; clean
	Battery	Check terminals; clean; test
XU	Front Gearcase Lubricant	Inspect / add lubricant if needed
XU	Transmission Lubricant (AGL)	Inspect / add lubricant if needed
XU	General Lubrication	Lubricate all fittings, pivots, cables, etc.
D	Throttle Pedal	Inspect; replace if it sticks
	Throttle Body Intake Ducts/Flange	Inspect ducts for proper sealing / air leaks
	Shift Cable / Linkage	Inspect; adjust as needed
D	Steering	Lubricate (if applicable)
XU	Front / Rear Suspension	Lubricate (if applicable)
D	Cooling System	Inspect coolant strength seasonally; pressure test system yearly
D	Drive Belt	Inspect; replace as needed
D	Clutches (Drive and Driven)	Inspect; clean; replace worn parts
XU	Engine Oil Lines/Fasteners	Inspect for leaks and loose fittings
XU	Spray Suppression Valances	Clean regularly
XU	Seat Adjuster	Lubricate long threaded bolt and all pivot pins

XU - Perform these procedures more often for Tractor subjected to severe use.

D - Have an authorized Egimotors dealer perform these services.

75 HOUR / 750 MILE (1200 KM)SERVICE

ITEM		REMARKS
XU / D	Brake Pads / Parking Brake Pads (INT'L)	Inspect pad wear; replace if worn beyond service limit
	Fuel System	Turn key on to pressurize fuel pump; check lines / fittings for leaks and abrasion
XU / D	Parking Brake Cable Adjustment (INT'L)	Inspect; adjust tension if necessary
XU	Engine Breather	Inspect; clean
	Battery	Check terminals; clean; test
XU	Engine Oil & Filter Change	Change oil and filter, inspect used oil for contaminants
XU	Front Gearcase Lubricant	Inspect / add lubricant if needed
XU	Transmission Lubricant (AGL)	Inspect / add lubricant if needed

XU - Perform these procedures more often for Tractor subjected to severe use. D

- Have an authorized Egimotors dealer perform these services.

MAINTENANCE

100 HOUR / 1000 MILE (1600 KM) SERVICE

ITEM		REMARKS
XU /D	Brake Pads / Parking Brake Pads (INT'L)	Inspect pad wear; replace if worn beyond service limit
	Fuel System	Turn key on to pressurize fuel pump; check lines / fittings for leaks and abrasion
XU /D	Parking Brake Cable Adjustment (INT'L)	Inspect; adjust tension if necessary
XU	Engine Breather	Inspect; clean
	Battery	Check terminals; clean; test
XU	General Lubrication	Lubricate all fittings, pivots, cables, etc.
D	Throttle Pedal	Inspect; replace if it sticks
	Throttle Body Intake Ducts/Flange	Inspect ducts for proper sealing / air leaks
	Shift Cable / Linkage	Inspect; adjust as needed
D	Steering	Lubricate (if applicable)
XU	Front / Rear Suspension	Lubricate (if applicable)
D	Cooling System	Inspect coolant strength seasonally; pressure test system yearly
D	Drive Belt	Inspect; replace as needed
XU	Engine Oil Lines/Fasteners	Inspect for leaks and loose fittings
XU /D	Parking Brake Cable Adjustment (INT'L)	Inspect; adjust tension as needed
XU	Front Gearcase Lubricant	Change lubricant
XU	Transmission Lubricant (AGL)	Change lubricant
D	Fuel System	Check for leaks at fill cap, fuel line / rail, and fuel pump.
D	Spark Plug Inspection	Inspect; replace as needed; torque to specification
XU	Radiator	Inspect; clean external surfaces
XU	Cooling Hoses	Inspect for leaks; pressure test system
XU	Engine Mounts	Inspect, torque to specification
	Exhaust Silencer / Pipe	Inspect

MAINTENANCE

ITEM		REMARKS
XU	Wiring	Inspect for wear, routing, security; inspect connectors subjected to water, mud, etc.
D	Clutches (Drive and Driven)	Inspect; clean; replace worn parts
D	Front Wheel Bearings	Inspect; replace as needed
XU	Shocks	Visually inspect shock seals; change oil and seals if leaking
	Cam Chain Tensioner	Inspect/clean; replace as needed
XU	Spray Suppression Valances	Clean regularly
XU	Seat Adjuster	Lubricate long threaded bolt and all pivot pins

XU - Perform these procedures more often for Tractor subjected to severe use. D

- Have an authorized Egimotors dealer perform these services.

MAINTENANCE

125 HOUR / 1250 MILE (2000 KM) SERVICE

ITEM		REMARKS
XU / D	Brake Pads / Parking Brake Pads (INT'L)	Inspect pad wear; replace if worn beyond service limit
	Fuel System	Turn key on to pressurize fuel pump; check lines / fittings for leaks and abrasion
XU / D	Parking Brake Cable Adjustment (INT'L)	Inspect; adjust tension if necessary
XU	Engine Breather	Inspect; clean
	Battery	Check terminals; clean; test
XU	Engine Oil & Filter Change	Change oil and filter, inspect used oil for contaminants
XU	Front Gearcase Lubricant	Inspect / add lubricant if needed
XU	Transmission Lubricant (AGL)	Inspect / add lubricant if needed

XU - Perform these procedures more often for Tractor subjected to severe use.

D - Have an authorized Egimotors dealer perform these services.

150 HOUR / 1500 MILE (2400 KM) SERVICE

ITEM		REMARKS
XU / D	Brake Pads / Parking Brake Pads (INT'L)	Inspect pad wear; replace if worn beyond service limit
	Fuel System	Turn key on to pressurize fuel pump; check lines / fittings for leaks and abrasion
XU / D	Parking Brake Cable Adjustment (INT'L)	Inspect; adjust tension if necessary
XU	Engine Breather	Inspect; clean
	Battery	Check terminals; clean; test
XU	Front Gearcase Lubricant	Inspect / add lubricant if needed
XU	Transmission Lubricant (AGL)	Inspect / add lubricant if needed
XU	General Lubrication	Lubricate all fittings, pivots, cables, etc.
D	Throttle Pedal	Inspect; replace if it sticks
	Throttle Body Intake Ducts/Flange	Inspect ducts for proper sealing / air leaks
	Shift Cable / Linkage	Inspect; adjust as needed
D	Steering	Lubricate (if applicable)
XU	Front / Rear Suspension	Lubricate (if applicable)
D	Cooling System	Inspect coolant strength seasonally; pressure test system yearly
D	Drive Belt	Inspect; replace as needed
D	Clutches (Drive and Driven)	Inspect; clean; replace worn parts
XU	Engine Oil Lines/Fasteners	Inspect for leaks and loose fittings
XU	Spray Suppression Valances	Clean regularly
XU	Seat Adjuster	Lubricate long threaded bolt and all pivot pins

XU - Perform these procedures more often for Tractor subjected to severe use. D

- Have an authorized Egimotors dealer perform these services.

MAINTENANCE

175 HOUR / 1750 MILE (2800 KM) SERVICE

ITEM		REMARKS
XU / D	Brake Pads / Parking Brake Pads (INT'L)	Inspect pad wear; replace if worn beyond service limit
	Fuel System	Turn key on to pressurize fuel pump; check lines / fittings for leaks and abrasion
XU / D	Parking Brake Cable Adjustment (INT'L)	Inspect; adjust tension if necessary
XU	Engine Breather	Inspect; clean
	Battery	Check terminals; clean; test
XU	Engine Oil & Filter Change	Change oil and filter, inspect used oil for contaminants
XU	Front Gearcase Lubricant	Inspect / add lubricant if needed
XU	Transmission Lubricant (AGL)	Inspect / add lubricant if needed

XU - Perform these procedures more often for Tractor subjected to severe use.

D - Have an authorized Egimotors dealer perform these services.

200 HOUR / 2000 MILE (3200 KM) SERVICE

ITEM		REMARKS
XU / D	Brake Pads / Parking Brake Pads (INT'L)	Inspect pad wear; replace if worn beyond service limit
	Fuel System	Turn key on to pressurize fuel pump; check lines / fittings for leaks and abrasion
XU / D	Parking Brake Cable Adjustment (INT'L)	Inspect; adjust tension if necessary
XU	Engine Breather	Inspect; clean
	Battery	Check terminals; clean; test
XU	General Lubrication	Lubricate all fittings, pivots, cables, etc.
D	Throttle Pedal	Inspect; replace if it sticks
	Throttle Body Intake Ducts/Flange	Inspect ducts for proper sealing / air leaks
	Shift Cable / Linkage	Inspect; adjust as needed
D	Steering	Lubricate (if applicable)
XU	Front / Rear Suspension	Lubricate (if applicable)
D	Cooling System	Inspect coolant strength seasonally; pressure test system yearly
D	Drive Belt	Inspect; replace as needed
D	Clutches (Drive and Driven)	Inspect; clean; replace worn parts
XU	Engine Oil Lines/Fasteners	Inspect for leaks and loose fittings
XU / D	Parking Brake Cable Adjustment (INT'L)	Inspect; adjust tension as needed
XU	Front Gearcase Lubricant	Change lubricant
XU	Transmission Lubricant (AGL)	Change lubricant
D	Fuel System	Check for leaks at fill cap, fuel line / rail, and fuel pump.
D	Spark Plug Inspection	Inspect; replace as needed; torque to specification
XU	Radiator	Inspect; clean external surfaces
XU	Cooling Hoses	Inspect for leaks; pressure test system

MAINTENANCE

ITEM		REMARKS
XU	Engine Mounts	Inspect, torque to specification
	Exhaust Silencer / Pipe	Inspect
XU	Wiring	Inspect routing and for wear; inspect connectors subjected to water/mud.
D	Front Wheel Bearings	Inspect; replace as needed
XU/ D	Shocks	Change shock oil and inspect seals
D	Brake Fluid	Change every two years (DOT 4)
	Spark Arrestor	Clean daily if driven in mud / water; replace a damaged arrestor before operating
	Cam Chain Tensioner	Inspect/clean; replace as needed
D	Valve Clearance	Inspect; adjust as needed
XU	Spray Suppression Valances	Clean regularly
XU	Seat Adjuster	Lubricate long threaded bolt and all pivot pins

XU - Perform these procedures more often for Tractor subjected to severe use.

D - Have an authorized Egimotors dealer perform these services.

225 HOUR / 2250 MILE (3600 KM) SERVICE

ITEM		REMARKS
XU / D	Brake Pads / Parking Brake Pads (INT'L)	Inspect pad wear; replace if worn beyond service limit
	Fuel System	Turn key on to pressurize fuel pump; check lines / fittings for leaks and abrasion
XU / D	Parking Brake Cable Adjustment (INT'L)	Inspect; adjust tension if necessary
XU	Engine Breather	Inspect; clean
	Battery	Check terminals; clean; test
XU	Engine Oil & Filter Change	Change oil and filter, inspect used oil for contaminants
XU	Front Gearcase Lubricant	Inspect / add lubricant if needed
XU	Transmission Lubricant (AGL)	Inspect / add lubricant if needed

XU - Perform these procedures more often for Tractor subjected to severe use. D

- Have an authorized Egimotors dealer perform these services.

MAINTENANCE

250 HOUR / 2500 MILE (4000 KM) SERVICE

ITEM		REMARKS
XU /D	Brake Pads / Parking Brake Pads (INT'L)	Inspect pad wear; replace if worn beyond service limit
	Fuel System	Turn key on to pressurize fuel pump; check lines / fittings for leaks and abrasion
XU /D	Parking Brake Cable Adjustment (INT'L)	Inspect; adjust tension if necessary
XU	Engine Breather	Inspect; clean
	Battery	Check terminals; clean; test
XU	Front Gearcase Lubricant	Inspect / add lubricant if needed
XU	Transmission Lubricant (AGL)	Inspect / add lubricant if needed
XU	General Lubrication	Lubricate all fittings, pivots, cables, etc.
D	Throttle Pedal	Inspect; replace if it sticks
	Throttle Body Intake Ducts/Flange	Inspect ducts for proper sealing / air leaks
	Shift Cable / Linkage	Inspect; adjust as needed
D	Steering	Lubricate (if applicable)
XU	Front / Rear Suspension	Lubricate (if applicable)
D	Cooling System	Inspect coolant strength seasonally; pressure test system yearly
D	Drive Belt	Inspect; replace as needed
D	Clutches (Drive and Driven)	Inspect; clean; replace worn parts
XU	Engine Oil Lines/Fasteners	Inspect for leaks and loose fittings
XU	Spray Suppression Valances	Clean regularly
XU	Seat Adjuster	Lubricate long threaded bolt and all pivot pins

XU - Perform these procedures more often for Tractor subjected to severe use.

D - Have an authorized Egimotors dealer perform these services.

275 HOUR / 2750 MILE (4400 KM) SERVICE

ITEM		REMARKS
XU / D	Brake Pads / Parking Brake Pads (INT'L)	Inspect pad wear; replace if worn beyond service limit
	Fuel System	Turn key on to pressurize fuel pump; check lines / fittings for leaks and abrasion
XU / D	Parking Brake Cable Adjustment (INT'L)	Inspect; adjust tension if necessary
XU	Engine Breather	Inspect; clean
	Battery	Check terminals; clean; test
XU	Engine Oil & Filter Change	Change oil and filter, inspect used oil for contaminants
XU	Front Gearcase Lubricant	Inspect / add lubricant if needed
XU	Transmission Lubricant (AGL)	Inspect / add lubricant if needed

XU - Perform these procedures more often for Tractor subjected to severe use. D

- Have an authorized Egimotors dealer perform these services.

MAINTENANCE

300 HOUR / 3000 MILE (4800 KM) SERVICE

ITEM		REMARKS
XU / D	Brake Pads / Parking Brake Pads (INT'L)	Inspect pad wear; replace if worn beyond service limit
	Fuel System	Turn key on to pressurize fuel pump; check lines / fittings for leaks and abrasion
XU / D	Parking Brake Cable Adjustment (INT'L)	Inspect; adjust tension if necessary
XU	Engine Breather	Inspect; clean
	Battery	Check terminals; clean; test
XU	General Lubrication	Lubricate all fittings, pivots, cables, etc.
D	Throttle Pedal	Inspect; replace if it sticks
	Throttle Body Intake Ducts/Flange	Inspect ducts for proper sealing / air leaks
	Shift Cable / Linkage	Inspect; adjust as needed
D	Steering	Lubricate (if applicable)
XU	Front / Rear Suspension	Lubricate (if applicable)
D	Cooling System	Inspect coolant strength seasonally; pressure test system yearly
D	Drive Belt	Inspect; replace as needed
D	Clutches (Drive and Driven)	Inspect; clean; replace worn parts
XU	Engine Oil Lines/Fasteners	Inspect for leaks and loose fittings
XU / D	Parking Brake Cable Adjustment (INT'L)	Inspect; adjust tension as needed
XU	Front Gearcase Lubricant	Change lubricant
XU	Transmission Lubricant (AGL)	Change lubricant
D	Fuel System	Check for leaks at fill cap, fuel line / rail, and fuel pump.
D	Spark Plug Inspection	Inspect; replace as needed; torque to specification
XU	Radiator	Inspect; clean external surfaces
XU	Cooling Hoses	Inspect for leaks; pressure test system

MAINTENANCE

ITEM		REMARKS
XU	Engine Mounts	Inspect, torque to specification
	Exhaust Silencer / Pipe	Inspect
XU	Wiring	Inspect for wear, routing, security; inspect connectors subjected to water, mud, etc.
D	Front Wheel Bearings	Inspect; replace as needed
XU	Shocks	Visually inspect shock seals; change oil and seals if leaking
	Cam Chain Tensioner	Inspect/clean; replace as needed
XU	Spray Suppression Valances	Clean regularly
XU	Seat Adjuster	Lubricate long threaded bolt and all pivot pins

XU - Perform these procedures more often for Tractor subjected to severe use. D

- Have an authorized Egimotors dealer perform these services.

MAINTENANCE

325 HOUR / 3250 MILE (5200 KM) SERVICE

ITEM		REMARKS
XU /D	Brake Pads / Parking Brake Pads (INT'L)	Inspect pad wear; replace if worn beyond service limit
	Fuel System	Turn key on to pressurize fuel pump; check lines / fittings for leaks and abrasion
XU /D	Parking Brake Cable Adjustment (INT'L)	Inspect; adjust tension if necessary
XU	Engine Breather	Inspect; clean
	Battery	Check terminals; clean; test
XU	Engine Oil & Filter Change	Change oil and filter, inspect used oil for contaminants
XU	Front Gearcase Lubricant	Inspect / add lubricant if needed
XU	Transmission Lubricant (AGL)	Inspect / add lubricant if needed

XU - Perform these procedures more often for Tractor subjected to severe use.

D - Have an authorized Egimotors dealer perform these services.

350 HOUR / 3500 MILE (5600 KM) SERVICE

ITEM		REMARKS
XU / D	Brake Pads / Parking Brake Pads (INT'L)	Inspect pad wear; replace if worn beyond service limit
	Fuel System	Turn key on to pressurize fuel pump; check lines / fittings for leaks and abrasion
XU / D	Parking Brake Cable Adjustment (INT'L)	Inspect; adjust tension if necessary
XU	Engine Breather	Inspect; clean
	Battery	Check terminals; clean; test
XU	Front Gearcase Lubricant	Inspect / add lubricant if needed
XU	Transmission Lubricant (AGL)	Inspect / add lubricant if needed
XU	General Lubrication	Lubricate all fittings, pivots, cables, etc.
D	Throttle Pedal	Inspect; replace if it sticks
	Throttle Body Intake Ducts/Flange	Inspect ducts for proper sealing / air leaks
	Shift Cable / Linkage	Inspect; adjust as needed
D	Steering	Lubricate (if applicable)
XU	Front / Rear Suspension	Lubricate (if applicable)
D	Cooling System	Inspect coolant strength seasonally; pressure test system yearly
D	Drive Belt	Inspect; replace as needed
D	Clutches (Drive and Driven)	Inspect; clean; replace worn parts
XU	Engine Oil Lines/Fasteners	Inspect for leaks and loose fittings
XU	Spray Suppression Valances	Clean regularly
XU	Seat Adjuster	Lubricate long threaded bolt and all pivot pins

XU - Perform these procedures more often for Tractor subjected to severe use. D

- Have an authorized Egimotors dealer perform these services.

MAINTENANCE

375 HOUR / 3750 MILE (6000 KM) SERVICE

ITEM		REMARKS
XU /D	Brake Pads / Parking Brake Pads (INT'L)	Inspect pad wear; replace if worn beyond service limit
	Fuel System	Turn key on to pressurize fuel pump; check lines / fittings for leaks and abrasion
XU /D	Parking Brake Cable Adjustment (INT'L)	Inspect; adjust tension if necessary
XU	Engine Breather	Inspect; clean
	Battery	Check terminals; clean; test
XU	Engine Oil & Filter Change	Change oil and filter, inspect used oil for contaminants
XU	Front Gearcase Lubricant	Inspect / add lubricant if needed
XU	Transmission Lubricant (AGL)	Inspect / add lubricant if needed

XU - Perform these procedures more often for Tractor subjected to severe use.

D - Have an authorized Egimotors dealer perform these services.

400 HOUR / 4000 MILE (6400 KM) SERVICE

ITEM		REMARKS
XU / D	Brake Pads / Parking Brake Pads (INT'L)	Inspect pad wear; replace if worn beyond service limit
	Fuel System	Turn key on to pressurize fuel pump; check lines / fittings for leaks and abrasion
XU / D	Parking Brake Cable Adjustment (INT'L)	Inspect; adjust tension if necessary
XU	Engine Breather	Inspect; clean
	Battery	Check terminals; clean; test
XU	General Lubrication	Lubricate all fittings, pivots, cables, etc.
D	Throttle Pedal	Inspect; replace if it sticks
	Throttle Body Intake Ducts/Flange	Inspect ducts for proper sealing / air leaks
	Shift Cable / Linkage	Inspect; adjust as needed
D	Steering	Lubricate (if applicable)
XU	Front / Rear Suspension	Lubricate (if applicable)
D	Cooling System	Inspect coolant strength seasonally; pressure test system yearly
D	Drive Belt	Inspect; replace as needed
D	Clutches (Drive and Driven)	Inspect; clean; replace worn parts
XU	Engine Oil Lines/Fasteners	Inspect for leaks and loose fittings
XU / D	Parking Brake Cable Adjustment (INT'L)	Inspect; adjust tension as needed
XU	Front Gearcase Lubricant	Change lubricant
XU	Transmission Lubricant (AGL)	Change lubricant
D	Fuel System	Check for leaks at fill cap, fuel line / rail, and fuel pump.
D	Spark Plug Inspection	Inspect; replace as needed; torque to specification
XU	Radiator	Inspect; clean external surfaces
XU	Cooling Hoses	Inspect for leaks; pressure test system

MAINTENANCE

ITEM		REMARKS
XU	Engine Mounts	Inspect, torque to specification
	Exhaust Silencer / Pipe	Inspect
XU	Wiring	Inspect for wear, routing, security; inspect connectors subjected to water, mud, etc.
D	Front Wheel Bearings	Inspect; replace as needed
XU / D	Shocks	Change shock oil and inspect seals
D	Brake Fluid	Change every two years (DOT 4)
	Spark Arrestor	Clean daily if driven in mud / water; replace a damaged arrestor before operating
	Cam Chain Tensioner	Inspect/clean; replace as needed
D	Valve Clearance	Inspect; adjust as needed
XU	Spray Suppression Valances	Clean regularly
XU	Seat Adjuster	Lubricate long threaded bolt and all pivot pins

XU - Perform these procedures more often for Tractor subjected to severe use.

D - Have an authorized Egimotors dealer perform these services.

425 HOUR / 4250 MILE (6800 KM) SERVICE

ITEM		REMARKS
XU / D	Brake Pads / Parking Brake Pads (INT'L)	Inspect pad wear; replace if worn beyond service limit
	Fuel System	Turn key on to pressurize fuel pump; check lines / fittings for leaks and abrasion
XU / D	Parking Brake Cable Adjustment (INT'L)	Inspect; adjust tension if necessary
XU	Engine Breather	Inspect; clean
	Battery	Check terminals; clean; test
XU	Engine Oil & Filter Change	Change oil and filter, inspect used oil for contaminants
XU	Front Gearcase Lubricant	Inspect / add lubricant if needed
XU	Transmission Lubricant (AGL)	Inspect / add lubricant if needed

XU - Perform these procedures more often for Tractor subjected to severe use. D

- Have an authorized Egimotors dealer perform these services.

MAINTENANCE

450 HOUR / 4500 MILE (7200 KM) SERVICE

ITEM		REMARKS
XU /D	Brake Pads / Parking Brake Pads (INT'L)	Inspect pad wear; replace if worn beyond service limit
	Fuel System	Turn key on to pressurize fuel pump; check lines / fittings for leaks and abrasion
XU /D	Parking Brake Cable Adjustment (INT'L)	Inspect; adjust tension if necessary
XU	Engine Breather	Inspect; clean
	Battery	Check terminals; clean; test
XU	Front Gearcase Lubricant	Inspect / add lubricant if needed
XU	Transmission Lubricant (AGL)	Inspect / add lubricant if needed
XU	General Lubrication	Lubricate all fittings, pivots, cables, etc.
D	Throttle Pedal	Inspect; replace if it sticks
	Throttle Body Intake Ducts/Flange	Inspect ducts for proper sealing / air leaks
	Shift Cable / Linkage	Inspect; adjust as needed
D	Steering	Lubricate (if applicable)
XU	Front / Rear Suspension	Lubricate (if applicable)
D	Cooling System	Inspect coolant strength seasonally; pressure test system yearly
D	Drive Belt	Inspect; replace as needed
D	Clutches (Drive and Driven)	Inspect; clean; replace worn parts
XU	Engine Oil Lines/Fasteners	Inspect for leaks and loose fittings
XU	Spray Suppression Valances	Clean regularly
XU	Seat Adjuster	Lubricate long threaded bolt and all pivot pins

XU - Perform these procedures more often for Tractor subjected to severe use.

D - Have an authorized Egimotors dealer perform these services.

475 HOUR / 4750 MILE (7600 KM) SERVICE

ITEM		REMARKS
XU / D	Brake Pads / Parking Brake Pads (INT'L)	Inspect pad wear; replace if worn beyond service limit
	Fuel System	Turn key on to pressurize fuel pump; check lines / fittings for leaks and abrasion
XU / D	Parking Brake Cable Adjustment (INT'L)	Inspect; adjust tension if necessary
XU	Engine Breather	Inspect; clean
	Battery	Check terminals; clean; test
XU	Engine Oil & Filter Change	Change oil and filter, inspect used oil for contaminants
XU	Front Gearcase Lubricant	Inspect / add lubricant if needed
XU	Transmission Lubricant (AGL)	Inspect / add lubricant if needed

XU - Perform these procedures more often for Tractor subjected to severe use. D

- Have an authorized Egimotors dealer perform these services.

MAINTENANCE

500 HOUR / 5000 MILE (8000 KM) SERVICE

ITEM		REMARKS
XU /D	Brake Pads / Parking Brake Pads (INT'L)	Inspect pad wear; replace if worn beyond service limit
	Fuel System	Turn key on to pressurize fuel pump; check lines / fittings for leaks and abrasion
XU /D	Parking Brake Cable Adjustment (INT'L)	Inspect; adjust tension if necessary
XU	Engine Breather	Inspect; clean
	Battery	Check terminals; clean; test
XU	General Lubrication	Lubricate all fittings, pivots, cables, etc.
D	Throttle Pedal	Inspect; replace if it sticks
	Throttle Body Intake Ducts/Flange	Inspect ducts for proper sealing / air leaks
	Shift Cable / Linkage	Inspect; adjust as needed
D	Steering	Lubricate (if applicable)
XU	Front / Rear Suspension	Lubricate (if applicable)
D	Cooling System	Inspect coolant strength seasonally; pressure test system yearly
D	Drive Belt	Inspect; replace as needed
XU	Engine Oil Lines/Fasteners	Inspect for leaks and loose fittings
XU /D	Parking Brake Cable Adjustment (INT'L)	Inspect; adjust tension as needed
XU	Front Gearcase Lubricant	Change lubricant
XU	Transmission Lubricant (AGL)	Change lubricant
D	Fuel System	Check for leaks at fill cap, fuel line / rail, and fuel pump.
D	Spark Plug Inspection	Inspect; replace as needed; torque to specification
XU	Radiator	Inspect; clean external surfaces
XU	Cooling Hoses	Inspect for leaks; pressure test system
XU	Engine Mounts	Inspect, torque to specification
	Exhaust Silencer / Pipe	Inspect

MAINTENANCE

ITEM		REMARKS
XU	Wiring	Inspect for wear, rotting, security; inspect connectors subjected to water, mud, etc.
D	Clutches (Drive and Driven)	Inspect; clean; replace worn parts
D	Front Wheel Bearings	Inspect; replace as needed
XU / D	Shocks	Change shock oil and inspect seals
D	Brake Fluid	Change every two years (DOT 4)
	Spark Arrestor	Clean daily if driven in mud / water; replace a damaged arrestor before operating
D	Valve Clearance	Inspect; adjust as needed
D	Spark Plug Replacement	Replace; torque to specification
XU	Coolant	Replace coolant
D	Toe Adjustment	Inspect periodically; adjust when parts are replaced
	Cam Chain Tensioner	Inspect/clean; replace as needed
XU	Spray Suppression Valances	Clean regularly
XU	Seat Adjuster	Lubricate long threaded bolt and all pivot pins

XU - Perform these procedures more often for Tractor subjected to severe use. D

- Have an authorized Egimotors dealer perform these services.

When the Tractor goes beyond 500 hours / 5000 Km, return to the 25 hours / 250 chart and start the interval process over.

MAINTENANCE

LUBRICATION RECOMMENDATIONS

Check and lubricate all components at the intervals outlined in the Periodic Maintenance Chart section, or more often under severe use, such as wet or dusty conditions. Items not listed in the chart should be lubricated at the general lubrication interval.

ITEM	LUBE	METHOD
Engine Oil	PS-4 5W-50 4-Cycle Oil and PS-4 Extreme Duty 10W-50 4-Cycle Oil	See page 106.
Brake Fluid	DOT 4 Brake Fluid	Maintain level between fill lines. See page 131.
Transmission Oil (Main Gearcase)	AGL Gearcase Lubricant & Transmission Fluid	See page 109.
Front Gearcase Fluid (Demand Drive)	Demand Drive Fluid	See page 111.
Prop Shaft	U-Joint Grease	Grease the middle and rear fittings.
Front Control Arm Pivot Bushings	All Season Grease or grease conforming to NLGI No. 2	Grease 3 fittings on each side of the Tractor.
Stabilizer Bar Bushings	All Season Grease or grease conforming to NLGI No. 2	Remove engine access panel and grease 2 fittings (one on each side of the Tractor).

Lubricate as recommended.

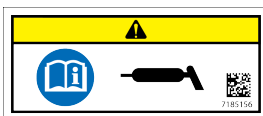

1 Middle Prop Shaft Grease Fitting

2 Rear Prop Shaft Grease Fitting

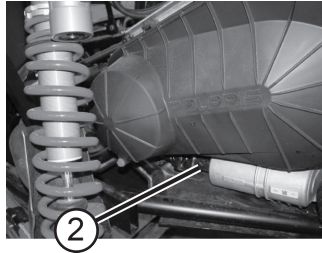
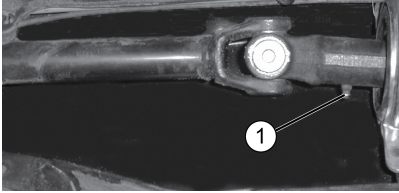

3 Stabilizer Bar Bushings (on each side of the Tractor)

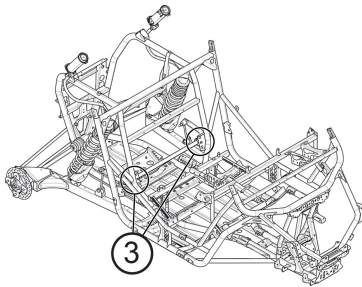

ENGINE OIL

OIL RECOMMENDATIONS

WARNING

Tractor operation with insufficient, deteriorated, or contaminated engine oil will cause accelerated wear and may result in engine seizure, accident, and injury. Always perform the maintenance procedures as outlined in the Periodic Maintenance Chart.

Ambient Temperature Range	Recommended Oil
(-37 °C) to (+38 °C)	PS-4 5W-50 4-Cycle Oil
(-18 °C) to (+49 °C)	PS-4 Extreme Duty 10W-50 4-Cycle Oil

Oil may need to be changed more frequently if EGIMOTORS oil is not used. Do not use automotive oil. Follow the manufacturer's recommendations for ambient temperature operation. Part numbers can be found in the EGIMOTORS Products chapter.

NOTICE

Mixing brands or using a non-recommended oil may cause serious engine damage. Always use the recommended oil. Never substitute or mix oil brands.

Always check and change the oil at the intervals outlined in the Periodic Maintenance Chart. Always use the recommended engine oil.

OIL CHECK

Always check the oil when the engine is cold. If the engine is hot when the oil is checked, the level will appear to be overfull.

Access the oil check dipstick *q* through the right rear wheel well. Access the oil fill cap *w* through the service access panel on the floor of the cargo box.

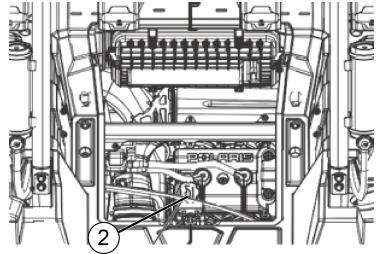
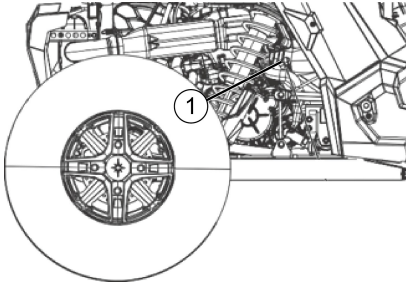

1. Position the Tractor on a level surface.
2. Place the transmission in PARK.
3. Start the engine. Allow the engine to idle for 30 seconds.
4. Stop the engine. Wait two (2) minutes to allow oil to drain back to the sump.
5. Remove the dipstick. Wipe it dry with a clean cloth.
6. Reinstall the dipstick completely. Remove the dipstick and check the oil level.
7. Remove the oil fill cap to add the recommended oil as needed. Maintain the oil level between the minimum and maximum marks on the dipstick. Do not overfill.
8. Reinstall the fill cap. Reinstall the dipstick.

MAINTENANCE

OIL AND FILTER CHANGE

Always change the oil and filter at the intervals outlined in the Periodic Maintenance Chart section. Always change the oil filter *q* whenever changing oil.

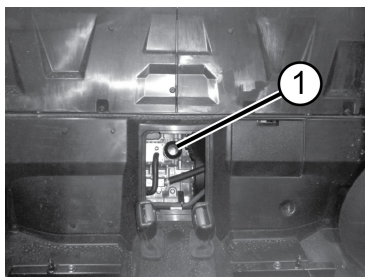

Access the oil check dipstick through the right rear wheel well. Access the oil fill cap through the service access panel on the floor of the cargo box.

The crankcase drain plug is located on the bottom of the crankcase. Access the drain plug through the access hole under the crankcase.

1. Position the Tractor on a level surface. Place the transmission in PARK.
2. Clean the area around the crankcase drain plug.

CAUTION

Hot oil can cause burns to skin. Do not allow hot oil to contact skin.

3. Place a drain pan under the engine crankcase and remove the drain plug. Allow the oil to drain completely.
4. Using an oil filter wrench, turn the filter counter-clockwise to remove it.
5. Using a clean dry cloth, clean the filter sealing surface on the crankcase.
6. Lubricate the o-ring on the new filter with a film of fresh engine oil. Check to make sure the o-ring is in good condition.
7. Install the new filter and turn by hand until the filter gasket contacts the sealing surface, then turn an additional 3/4 turn.
8. Reinstall the crankcase drain plug. Torque to 16 Nm.
9. Remove the oil fill cap and add 2.4 l of recommended oil. Reinstall the fill cap.
10. Start the engine and allow it to idle for 30 seconds.
11. Stop the engine. Wait 15 seconds before removing the dipstick.

12. Remove the dipstick. Wipe it dry with a clean cloth.
13. Reinstall the dipstick completely. Remove the dipstick and check the oil level.
14. Remove the oil fill cap to add the recommended oil as needed. Maintain the oil level between the minimum and maximum marks on the dipstick. Do not overfill.
15. Reinstall the fill cap.
16. Reinstall the dipstick.
17. Dispose of used filter and oil properly.

TRANSMISSION (MAIN GEARCASE)

Always check and change the fluid at the intervals outlined in the Periodic Maintenance Chart section. Refer to the Gearcase Specifications Chart section for recommended lubricants, capacities and torque specifications.

FLUID CHECK

The fill plug **q** is located on the rear of the gearcase. Maintain the fluid level at the bottom of the fill plug hole.

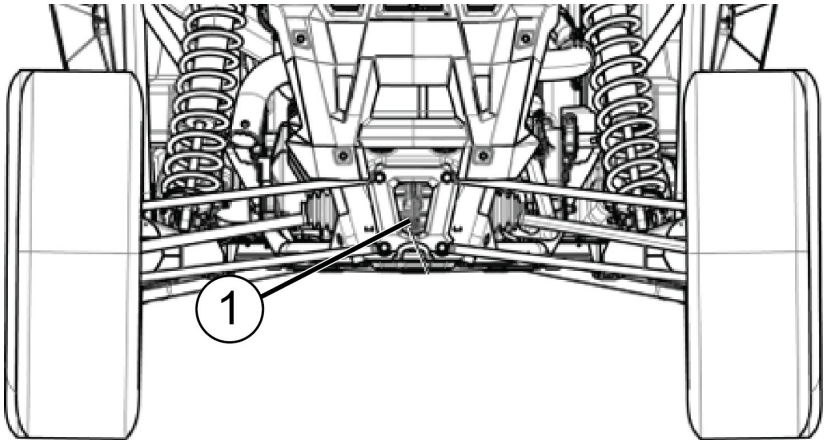

1. Position the Tractor on a level surface.
2. Remove the fill plug.
3. Check the fluid level.

MAINTENANCE

4. Add the recommended fluid (listed in the Gearcase Specifications Chart section of this manual) to the bottom of the fill plug hole. Do not overfill.
5. Reinstall the fill plug. Torque to specification (listed in the Gearcase Specifications Chart).

FLUID CHANGE

The drain plug q is located on the bottom of the gearcase. Access the drain plug through the drain hole in the skid plate.

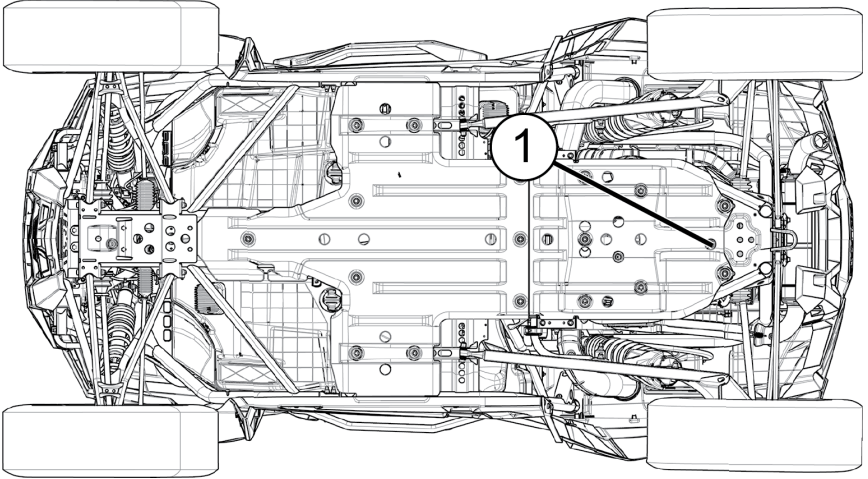

1. Remove the fill plug.
2. Place a drain pan under the drain plug.
3. Remove the drain plug. Allow the fluid to drain completely.
4. Clean the drain plug.
5. Reinstall the drain plug. Torque to specification (listed in the Gearcase Specification Chart of this manual).
6. Add the recommended fluid (listed in the Gearcase Specification Chart) to the bottom of the fill plug hole. Do not overfill.
7. Reinstall the fill plug. Torque to specification (listed in the Gearcase Specification Chart).
8. Check for leaks. Discard used fluid properly.

DEMAND DRIVE UNIT (FRONT GEARCASE)

Always check and change the fluid at the intervals outlined in the Periodic Maintenance Chart. Refer to the Gearcase Specifications Chart section for recommended lubricants, capacities and torque specifications.

DEMAND DRIVE FLUID CHECK

The fill plug q is located on the bottom right side of the demand drive unit. Maintain the fluid level so that it is even with the bottom thread of the fill plug hole.

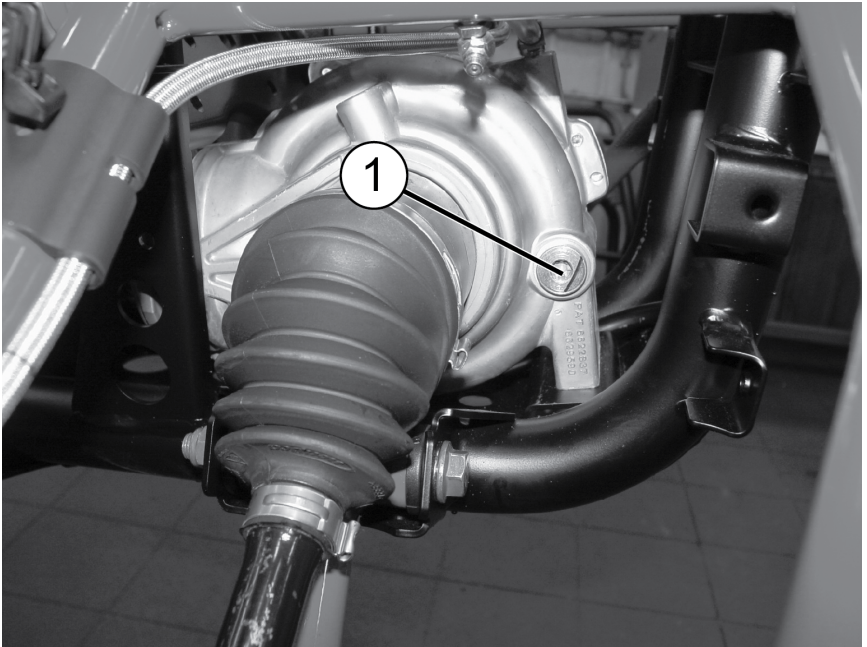

1. Position the Tractor on a level surface.
2. Remove the fill plug.
3. Check the fluid level to see if even with bottom thread of fill plug hole.
4. If fluid level is not even with bottom thread of fill plug hole, add the recommended fluid as necessary (fluid type is listed in the Gearcase Specification Chart section).
5. Reinstall the fill plug. Torque to specification (listed in the Gearcase Specification Chart section).

MAINTENANCE

DEMAND DRIVE FLUID CHANGE

The demand drive drain plug **q** is located on the bottom of the gearcase.

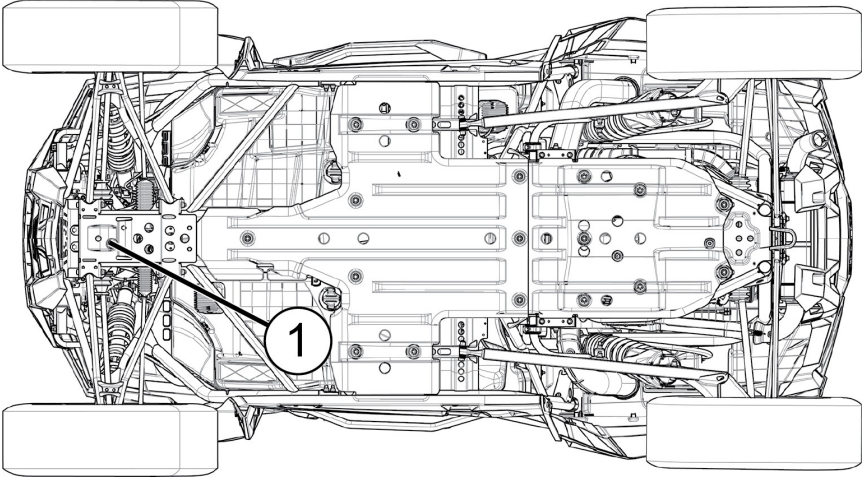

1. Remove the fill plug.
2. Place a drain pan under the drain plug.
3. Remove the drain plug. Allow the fluid to drain completely.
4. Clean the drain plug.
5. Reinstall the drain plug. Torque to specification (listed in the Gearcase Specification Chart of this manual).
6. Add the recommended fluid (listed in the Gearcase Specification Chart) to the bottom thread of the fill plug hole.
7. Reinstall the fill plug. Torque to specification listed in the Gearcase Specification Chart).
8. Check for leaks. Discard used fluid properly.

GEARCASE SPECIFICATION CHART

Use of other fluids may result in improper operation of components. See the EGIMOTORS Products section for part numbers.

GEARCASE	LUBRICANT	CAPACITY	FILL PLUG TORQUE	DRAIN PLUG TORQUE
Transmission (Main Gearcase)	AGL Gearcase Lubricant & Transmission Fluid	1300 ml <i>Turf Models:</i> 1200 ml	14-19 Nm	14-19 Nm
Demand Drive Unit (Front Gearcase)	Demand Drive Fluid	250 ml	11-14 Nm	11-14 Nm

SPARK PLUGS

SPARK PLUG GAP / TORQUE

Electrode Gap	Spark Plug Torque
0.7-0.8 mm	12 N·m

NOTICE

Using non-recommended spark plugs can result in serious engine damage. Always use POLARIS-recommended spark plugs or their equivalent. Refer to the Specifications section for details.

Spark plug condition is indicative of engine operation. The spark plug firing end condition should be read after the engine is warmed up and the Tractor is driven at higher speeds. Immediately check the spark plug for correct color.

CAUTION

A hot exhaust system and engine can cause burns. Wear protective gloves when removing a spark plug for inspection.

SPARK PLUG REMOVAL AND REPLACEMENT

1. Remove the cargo box access panel to access the spark plugs q.

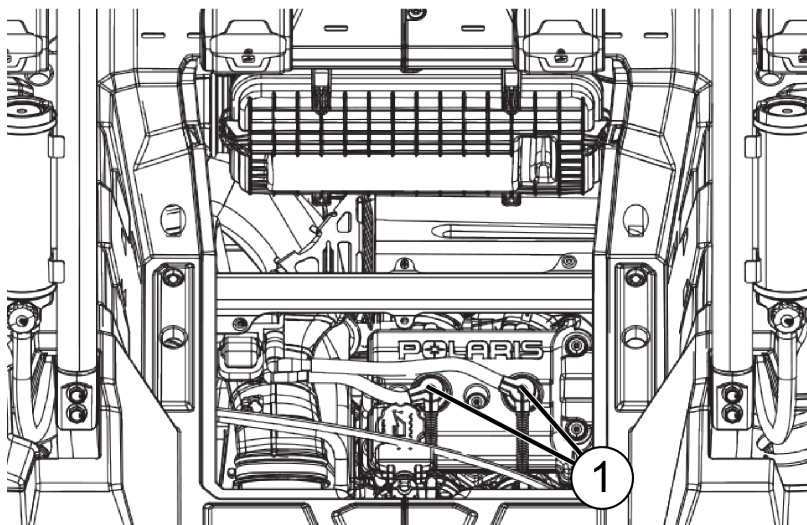

2. Clean the area around the spark plugs before removing the plugs.

3. Remove the spark plug caps.
4. Using the spark plug wrench provided in the tool kit, remove the plugs by rotating them counterclockwise.
5. Reverse the procedure for spark plug installation. Torque to specification.

SPARK PLUG CONDITION

NORMAL PLUG

The normal insulator tip is gray, tan or light brown. There will be few combustion deposits. The electrodes are not burned or eroded. This indicates the proper type and heat range for the engine and the service.

NOTICE
The tip should not be white. A white insulator tip indicates overheating, caused by use of an improper spark plug or incorrect throttle body adjustments.

WET FOULED PLUG

The wet fouled insulator tip is black. A damp oil film covers the firing end. There may be a carbon layer over the entire nose. Generally, the electrodes are not worn. Fouling may be caused by excessive oil or by frequent short trips, especially in cold weather.

MAINTENANCE

FUSE / RELAY CENTER

If the engine stops or will not start, if the power steering stops working (if equipped), or if you experience other electrical failures, a fuse may need replacement. Locate and correct any short circuits that may have caused the blown fuse, then replace the fuse. The fuse/relay center is located under the driver's side console.

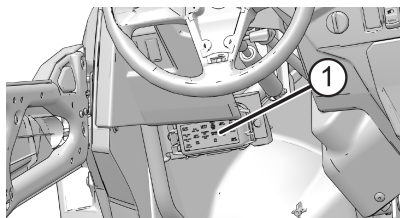

LABEL	VALUE	FUNCTION
FAN	20A Circuit Breaker	Engine Coolant Fan
FUEL	7.5A Fuse	Fuel Pump
TERM ACCY	10A Fuse	Under Hood Terminal Block <i>RZR XP 4 Tractor: Rear 12V Receptacle</i>
INSTR ACCY	15A Fuse	Interior LED, Diagnostic Port <i>RideCommand Tractor: Gauge Display</i>
SOCKET	10A Fuse	Dash 12V Receptacle
EPS	30A Fuse	Power Steering
INSTR UNSW	7.5A Fuse	Diagnostic Connector <i>RideCommand Tractor: Display</i>
LIGHTS	7.5A Fuse	Headlights, Taillights

LABEL	VALUE	FUNCTION
CHASSIS	10A Fuse	AWD Switch, Oxygen Sensor Heater, EPS Wake-Up, VSS, Seat Belt, AWD Coil, Gauge, Winch <i>Tractor:</i> SCM Wake-Up, SCM Mode Switch
CHASSIS 2	15A Fuse	Horn, Trailer Taillights, Position Lights, Operator Alarm, Fog Lights
FLASHER	10A Fuse	Turn Signals
EFI	10A Fuse	Accessory Relay Coil, ECM Wake-Up, Pump Relay Coil, Chassis Relay Coil, Start Relay Coil, EFI Relay Coil, Mag/PTO Inject, Lights Relay Coil, Fan Relay Coil, Ignition Relay Coil, Starter Solenoid Coil, Brake Relay Coil <i>Tractor:</i> SCM Relay Coil

COOLING SYSTEM

The engine coolant level is maintained by a remote pressurized tank system. The remote pressurized tank is connected to both radiators and provides a single pressure cap and fill point for the Tractor.

The pressure tank is designed to contain a volume of air above the coolant level. As coolant operating temperature increases the coolant level in the pressure tank will rise and push out air past the pressure cap. As the engine coolant temperature decreases the coolant level in the pressure tank will lower and draw air back into the tank through the pressure cap.

TIP

Some coolant level drop on new Tractor is normal as the system is purging itself of trapped air. Observe coolant levels and maintain cold coolant level as recommended by adding coolant to the pressure tank.

CAUTION

Escaping steam can cause burns. Never remove the pressure cap while the engine is warm or hot. Always allow the engine to cool before removing the pressure cap.

ADDING OR CHANGING COOLANT

EGIMOTORS recommends the use of EGIMOTORS Antifreeze 50/50 Premix. This antifreeze is already premixed and ready to use. Do not dilute with water. See the Egimotors Products section for the part numbers.

To ensure that the coolant maintains its ability to protect the engine, we recommend that the system be completely drained every five (5) years and fresh Antifreeze 50/50 Premix added.

Any time the cooling system has been drained for maintenance or repair, replace the coolant with fresh Antifreeze 50/50 Premix.

RADIATORS AND COOLING FAN

Always check and clean the screens and radiator fins at the intervals outlined in the Periodic Maintenance Chart section. Do not obstruct or deflect air flow through the radiators by installing unauthorized accessories in front of the radiators or behind the cooling fan. Interference with radiator air flow can lead to overheating and consequent engine damage.

NOTICE

Washing the Tractor with a high-pressure hose could damage radiator fins and impair a radiator's effectiveness. Using a high-pressure system is not recommended.

RADIATOR COOLANT LEVEL / CHANGING COOLANT

This procedure is required only if the cooling system has been drained for maintenance and/or repair. If the overflow bottle e has run dry, the level in the radiator should also be inspected.

CAUTION

Escaping steam can cause burns. Never remove the pressure cap while the engine is warm or hot. Always allow the engine to cool before removing the pressure cap.

1. Remove the hood. See the Hood section for details.
2. Slowly remove the radiator pressure cap w.
3. View the coolant level through the opening.
4. Use a funnel and slowly add coolant as needed.
5. Before reinstalling the pressure cap, bleed the system of trapped air. Remove the engine access panel behind the seats and use a flat-blade screwdriver to turn the bleed screw q slightly, allowing the air to escape. Slowly add additional coolant to the radiator until air no longer escapes and only coolant flows from the bleed hole, then tighten the bleed screw.
6. Reinstall the pressure cap.

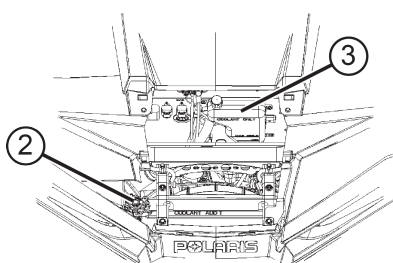
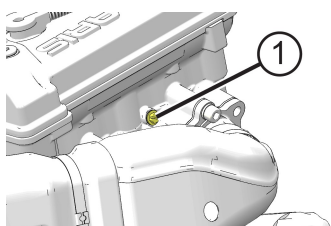

TIP

Use of a non-standard pressure cap will not allow the recovery system to function properly. See your dealer for the correct replacement part.

OVERFLOW BOTTLE COOLANT LEVEL

Always check and change the coolant at the intervals outlined in the Periodic Maintenance Chart section. Maintain the coolant level between the minimum and maximum marks on the bottle (when the fluid is cool). If the overflow bottle has run dry, the level in the radiator should also be inspected.

1. Position the Tractor on a level surface.
2. Remove the hood. See the Hood section for details.
3. View the coolant level in the overflow bottle q.

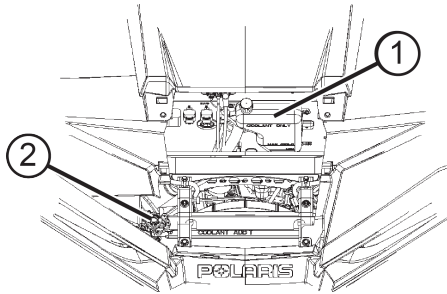

4. Remove the cap **w** and use a funnel to add coolant as needed to maintain the level between the two marks.
5. Reinstall the cap.

TIP

If coolant must be added often, or if the overflow bottle runs completely dry, there may be a leak in the system. Have the cooling system inspected by your EGIMOTORS dealer or authorized person.

VARIABLE TRANSMISSION (PVT) SYSTEM

WARNING

Failure to comply with the instructions in this warning can result in severe injury or death.

Do not modify any component of the PVT system. Doing so may reduce its strength so that a failure may occur at a high speed. The PVT system has been precision balanced. Any modification will cause the system to be out of balance, creating vibration and additional loads on components.

The PVT system rotates at high speeds, creating large amounts of force on clutch components. As the owner, you have the following responsibilities for your own safety and the safety of others:

- Always follow all recommended maintenance procedures. Always look for and remove debris inside and around the clutch and vent system when replacing the belt.
- See your dealer or other qualified service person as recommended in the owner's manual and on safety labels.
- Do not install it in any other product.
- Always make sure the PVT housing is securely in place during operation.

Belt slip is responsible for creating excessive heat that destroys belts, wears clutch components and causes outer clutch covers to fail. Switch to low range while operating at slower speeds to extend the life of the PVT components (belt, cover, etc.).

BELT REPLACEMENT / DEBRIS REMOVAL

If a belt fails, always clean any debris from the duct and from the clutch and engine compartments when replacing the belt.

WARNING

Failure to remove ALL debris when replacing the belt could result in Tractor damage, loss of control and severe injury or death.

1. Allow hot components to cool before performing this procedure.
2. Remove the engine access cover and thoroughly clean all debris from the aluminum debris basket *q* and from the engine compartment.

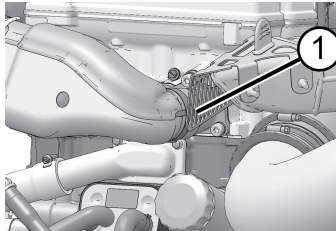

3. Remove the clutch cover screws and open the clutch cover. (It does not have to be removed from the Tractor.) Remove all debris wrapped in and around the PVT system.

TIP

Use the shock/clutch tool from the tool kit to slightly open the sheaves to aid in debris removal and belt installation.



Insert hooked end of tool



Apply force to opposite end of tool to spread sheaves

-
4. Remove ALL DEBRIS from the entire clutch air duct passage w.

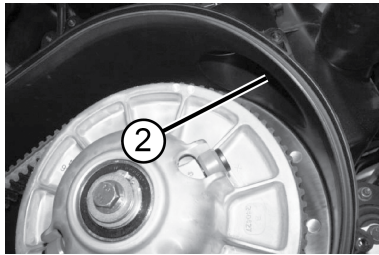

5. Check for signs of damage to seals on the transmission and engine. See your dealer promptly for service if any seals appear to be damaged.

TIP

Belt slip is responsible for creating excessive heat that destroys belts, wears clutch components and causes outer clutch covers to fail. Switch to low range while operating at slower speeds to extend the life of the PVT components (belt, cover, etc.).

PVT DRYING

There may be some instances when water is accidentally ingested into the PVT system. Use the following instructions to dry it out before operating.

NOTICE
When washing the Tractor, always avoid spraying water directly toward the PVT intake duct. See the Washing the Tractor section for details.

1. Remove the clutch cover drain plug.
2. Allow the water to drain. Reinstall the drain plug.
3. Place the transmission in PARK. Apply the brakes.
4. Start the engine.
5. Apply varying throttle for 10-15 seconds to expel the moisture and air-dry the belt and clutches. Do not hold the throttle wide open for more than 10 seconds.
6. Allow the engine RPM to settle to idle speed. Apply the brakes. Shift the transmission to the lowest available range.
7. Test for belt slippage. If the belt slips, repeat the process.
8. Your Tractor requires service as soon as possible. Your EGIMOTORS dealer or authorized person can assist.

FILTER SYSTEMS

INTAKE PRE-FILTERS

The engine intake pre-filter **q** is located on the right side of the Tractor. The clutch air intake **w** is located on the left side of the Tractor.

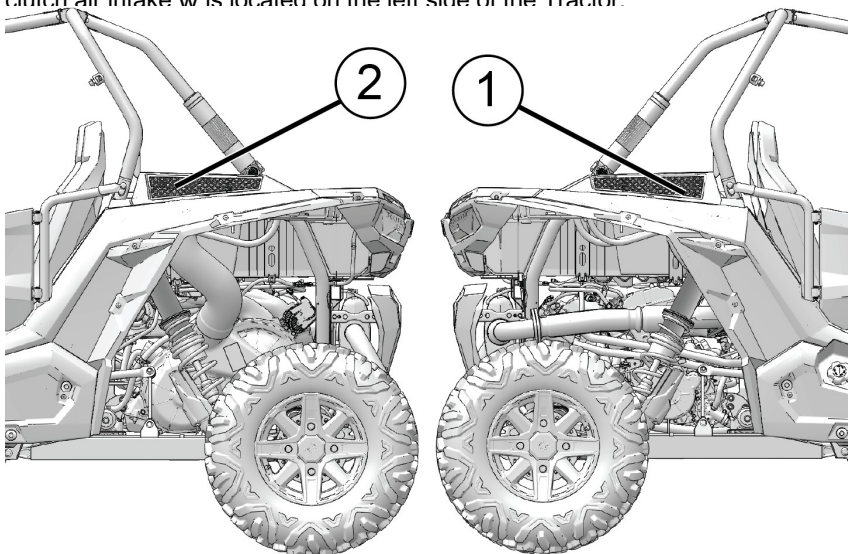

Inspect the engine pre-filter before each use of the Tractor to ensure adequate air flow. If necessary, remove the pre-filter and clean with soapy water. Dry with low pressure compressed air.

Periodically inspect the clutch (PVT) air intake for debris and clean as needed to ensure adequate air flow.

TIP

When washing the Tractor, always avoid spraying water directly toward the PVT intake duct. See the Washing the Tractor section for recommended washing procedures.

AIR FILTER

Always change the air filter at the intervals outlined in the Periodic Maintenance Chart.

1. Remove the cargo box access panel.
2. Clean all dirt and debris from the air box area.
3. Unlatch the four (4) air box cover clips and carefully remove the air box cover.
4. Inspect the air filter and air box for dirt, debris or water.

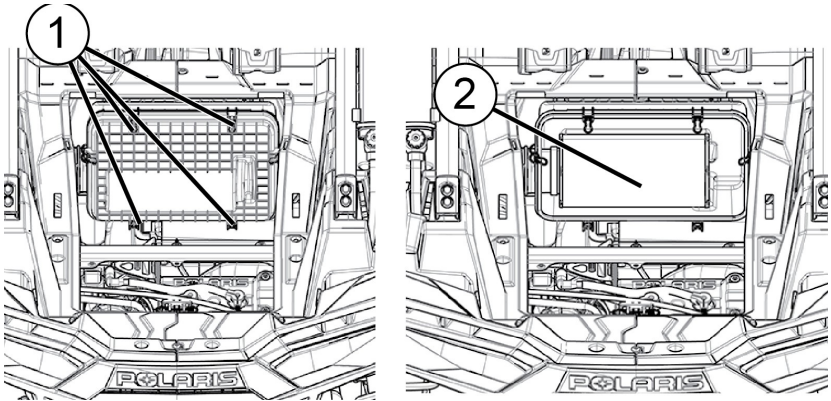

5. To remove the filter, slide the filter toward the passenger's side of the Tractor.
6. With the filter removed, clean the intake tube and air box thoroughly. Wipe well with a clean, dry cloth.

NOTICE

Dirt or debris in the intake tube could result in severe engine damage. Always clean all dirt and debris from the intake tube before installing the filter.

-
7. Reinstall the air filter (if clean) or install a new air filter (if soiled). Do not attempt to clean the air filter.

NOTICE

Use of a non approved air filter may cause engine damage. Always use a POLARIS-approved replacement filter. Replacement filters are available at your dealer.

8. Make sure that there are no gaps between the filter, the filter ring and the stop on the intake tube.
9. Reinstall the air box cover and ensure the alignment tabs are properly positioned.
10. Secure the four (4) cover clips.
11. Reinstall the cargo box access panel.

SPARK ARRESTER

WARNING

- Never operate the Tractor without the spark arrester.
- Remove any combustible materials from the area.

Failure to heed the following warnings while servicing the spark arrester could result in serious injury or death.

- Never run the engine in an enclosed area. Exhaust contains poisonous carbon monoxide gas that can cause loss of consciousness or death in a very short time.
- Do NOT perform service on the spark arrester while the system is HOT. Exhaust system temperatures can reach extreme temperatures. Allow components to cool sufficiently before proceeding.
- Do not stand behind or in front of the Tractor while purging the exhaust system.
- Never go under the Tractor while it is inclined.
- Wear eye protection and gloves while servicing.

Periodically clean the spark arrester to remove accumulated carbon. A plugged spark arrester will affect engine performance. Clean daily when driving in mud and water. Replace a cracked or damaged arrester before operating.

1. Remove the arrester retaining bolt 1 and nut 2.
2. Remove the arrester from the end of the muffler 3.
3. Use a non-synthetic brush to clean the arrester screen 4. A synthetic brush may melt if components are warm. If necessary, blow debris from the screen with compressed air.
4. Inspect the screen for wear and damage. Replace a worn or damaged screen.
5. Reinstall the arrester. Torque bolt to 10-12 N·m.

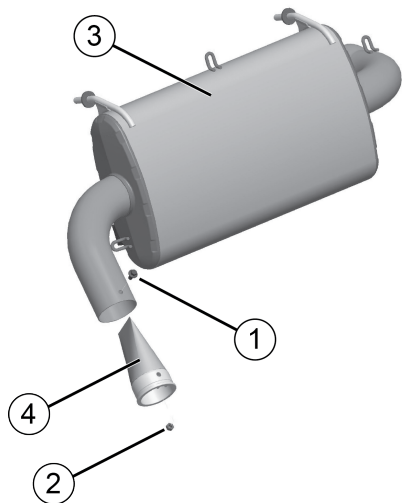

BRAKES

WARNING

Operating the Tractor with a spongy brake pedal can result in loss of braking, which could cause an accident resulting in severe injury or death. Never operate the Tractor with a spongy-feeling brake pedal.

The front and rear brakes are hydraulic disc type brakes activated by the brake pedal.

CAUTION

Brake discs can become extremely hot after operation. Allow the discs to cool before performing maintenance to prevent risk of burns.

Always check brake pedal travel and the brake fluid reservoir level before each use of the Tractor. When applied, the brake pedal should feel firm. Any sponginess would indicate a possible fluid leak or low brake fluid level, which must be corrected before riding. See the Brake Fluid section for further details.

If you discover any irregularities in brake system operation, including excessive pedal travel, contact your dealer for proper diagnosis and repairs.

BRAKE INSPECTION

WARNING

Do not apply WD-40® or any petroleum product to brake discs. These types of products are flammable and may also reduce the friction between the brake pad and caliper.

1. Check the brake system for fluid leaks.
2. Check the brake pedal for excessive travel or a spongy feel.
3. Check the friction pads for wear, damage and looseness.
4. Check brake discs for signs of cracks, excessive corrosion, warping or other damage. Clean any grease using an approved brake cleaner or alcohol.
5. Inspect the brake disc spline and pad wear surface for excessive wear. Change pads when worn to 0.762 mm (0.030") q.

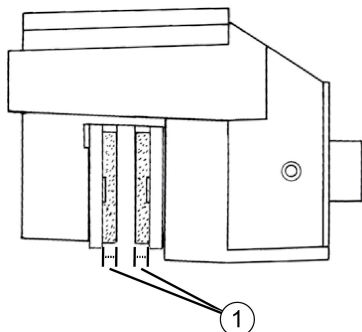

BRAKE FLUID

WARNING

After opening a bottle of brake fluid, always discard any unused portion. Never store or use a partial bottle. Brake fluid is hygroscopic, meaning it rapidly absorbs moisture from the air. The moisture causes the boiling temperature of the brake fluid to drop, which can lead to early brake fade and the possibility of accident or severe injury.

Inspect the level of the brake fluid before each operation. If the fluid level is low add DOT 4 brake fluid only. See the Egimotors Products section for the part numbers.

Change the brake fluid every two years and any time the fluid becomes contaminated, the fluid level is below the minimum, or if the type and brand of the fluid in the reservoir are unknown. Access the brake fluid reservoir through the left front wheel well.

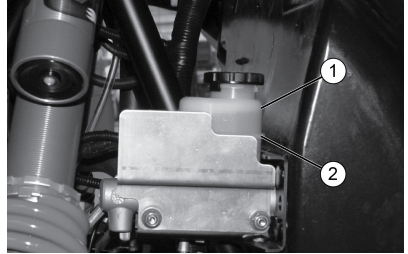

1. Position the Tractor on a level surface.
2. Place the transmission in PARK.
3. View the brake fluid level in the reservoir. The level should be between the maximum q and minimum w level lines.
4. If the fluid level is lower than the lower level line, add brake fluid to the upper line.
5. Apply the brake forcefully for a few seconds and check for fluid leakage around the fittings.

SUSPENSION SETTINGS

FRONT / REAR SHOCK COMPRESSION ADJUSTMENT

The compression damping clicker knob is located at the top of the shock reservoir.

1. Turn the clicker **clockwise** to **increase** compression damping.
2. Turn the clicker **counter-clockwise** to **decrease** compression damping.

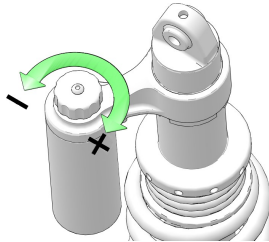

Shock Compression Settings		
Model	Location	Clicker Position
All Models with Walker Evans Racing® Shocks	Front	8/16 clicks
	Rear	8/16 clicks

FRONT / REAR SPRING PRELOAD ADJUSTMENT

The factory setting is appropriate for nearly all riding conditions. If desired, the suspension may be adjusted to maintain Tractor clearance height when carrying loads.

To adjust the preload, do the following:

1. Elevate the Tractor to allow the suspension to fully extend.
2. Turn the adjusting ring to the left to add preload. Turn the adjusting ring to the right to remove preload.

WARNING

Uneven adjustment may cause poor handling of the Tractor, which could result in an accident. Always adjust both the left and right spring preloads equally or have your EGIMOTORS dealer or qualified person perform the adjustments.

WALKER EVANS RACING® SHOCKS

1 Front Shock Preload Measurement

2 Rear Shock Preload Measurement

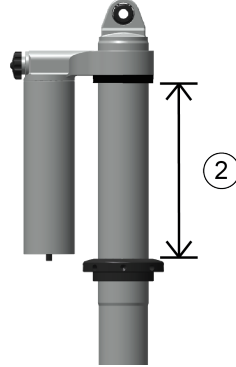
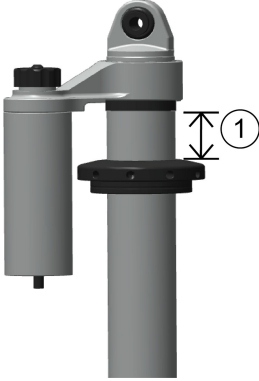

FACTORY DEFAULT PRELOAD SETTINGS

FACTORY DEFAULT PRELOAD SETTINGS		
RZR XP 4	WALKER EVANS RACING®	
	Front	51 mm (2.04 inches)
	Rear	148 mm (5.83 inches)

Follow these guidelines if you make adjustments to this suspension.

- Always return the suspension to the factory setting after the load is removed from the Tractor. The increased suspension height will negatively impact Tractor stability when operating without a load.
- Always apply the same adjustment setting to *all four wheels*.

Do not increase the spring preload by more than one inch (25.4 mm) over the factory setting.

TIRES

WARNING

Operating your Tractor with worn tires will increase the possibility of skidding, loss of control and an accident, which could result in serious injury or death. Always replace tires when the tread depth measures 1/8 in (3 mm) or less.

Improper tire inflation or the use of non-standard size or type of tires may adversely affect Tractor handling, which could result in Tractor damage or personal injury. Always maintain proper tire pressure. Always use POLARIS-approved size and type of tires for this Tractor when replacing tires.

Tires age even if they have not been used or have only been used occasionally. Cracking of the tread and sidewall rubber and/or deformation is evidence of aging. Tires should be inspected for aging before use. If signs of aging or damage are found, see your Egimotors' dealer or other qualified person for assistance.

TIRE TREAD DEPTH

Always replace tires when tread depth is worn to 3 mm (1/8") or less.

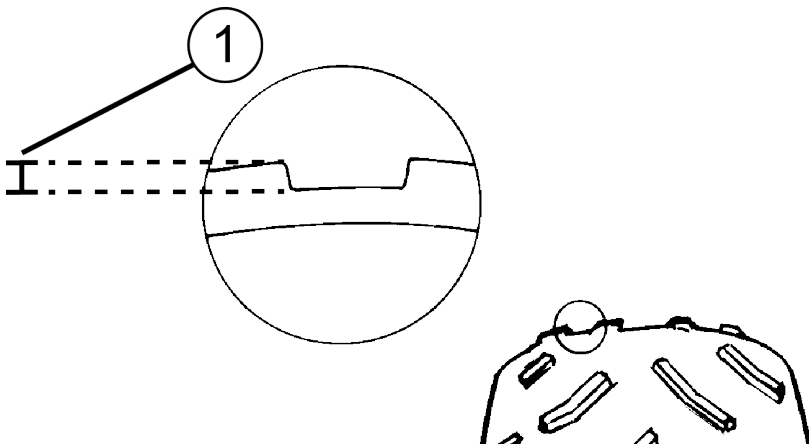

AXLE AND WHEEL NUT TORQUE SPECIFICATIONS

Inspect the following items occasionally for tightness, and if they've been loosened for maintenance service. *Do not lubricate the stud or the lug nut.*

Lug Nut (Aluminum Wheels) 	Front and Rear	160 N·m
Hub Retaining Nut	Front and Rear	244 N·m

WHEEL REMOVAL

1. Position the Tractor on a level surface.
2. Place the transmission in PARK. Stop the engine.
3. Engage the park brake.
4. Loosen the wheel nuts slightly.
5. Elevate the side of the Tractor by placing a suitable stand under the frame.
6. Remove the wheel lug nuts. Remove the wheel.

WHEEL INSTALLATION

⚠ WARNING

Improperly installed wheels can adversely affect tire wear and Tractor handling, which can result in serious injury or death. Always ensure that all nuts are torqued to specification. Do not service axle nuts that have a cotter pin installed. Your EGIMOTORS dealer can assist.

1. Place the transmission in PARK.
2. Place the wheel in the correct position on the wheel hub. Be sure the valve stem is toward the outside and rotation arrows on the tire point toward forward rotation.
3. Attach the wheel nuts and finger tighten.
4. Carefully lower the Tractor to the ground.
5. Torque the wheel nuts to specification. See the Axle and Wheel Nut Torque Specifications section for details.



Right Rear Wheel
(type varies by model)

LIGHTS

Headlight and taillight lenses become dirty during normal operation. Clean all lights frequently to ensure a clear field of vision as well as visibility to other Tractor.

TIP

LED LAMPS

If an LED headlamp appears to have moisture or fogging *inside* the lens, disconnect the wiring harness from the headlamp(s) for a few days to allow the moisture to clear out.

TIP

HALOGEN LAMPS

When servicing a halogen lamp, don't touch the lamp with bare fingers. Oil from your skin leaves a residue, causing a hot spot that will shorten the life of the lamp.

TAILLIGHT / BRAKE LIGHT / TURN SIGNAL LAMP REPLACEMENT

The taillight assembly is not serviceable. If the taillight or brake light fails to operate properly, replace the entire taillight assembly.

HEADLIGHT REPLACEMENT

If a headlight becomes damaged or inoperable, the entire headlight assembly must be replaced. Do not operate this Tractor at night or in low light conditions until the headlight is replaced. Always make sure lights are adjusted properly for best visibility.

FRONT TURN SIGNAL LAMP REPLACEMENT

If a front turn signal light becomes inoperable, the lamps cannot be replaced. Replace the entire signal lamp assembly.

HEADLIGHT BEAM ADJUSTMENT

The headlight beam can be adjusted slightly upward or downward and to the left or right.

NOTICE

Rider weight must be included on the seat while performing this procedure.

1. Position the Tractor on a level surface. The headlight should be approximately 7.6 m from a wall.

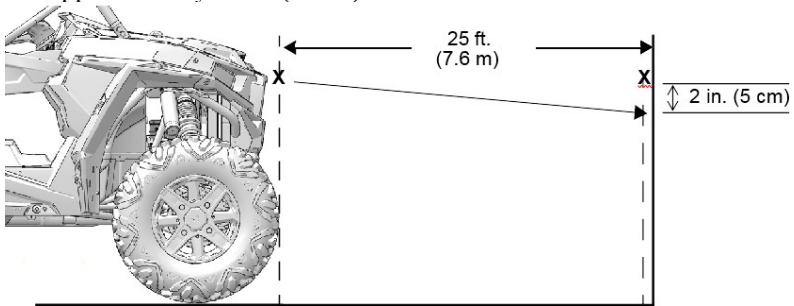

2. Place the transmission in PARK.
3. Measure the distance from the floor to the center of the headlight and make a mark on the wall at the same height.
4. Apply the brakes. Start the engine. Turn the headlights to high beam.

5. Include the weight of a rider on the seat while performing this step. Observe the headlight aim. As a starting point, the most intense part of the headlight beam should be 5 cm below the mark on the wall. Adjust to operator preference.
6. Tighten or loosen the three (3) headlight screws *q* on the rear of the headlight to adjust the beam upward or downward or to the left or right.

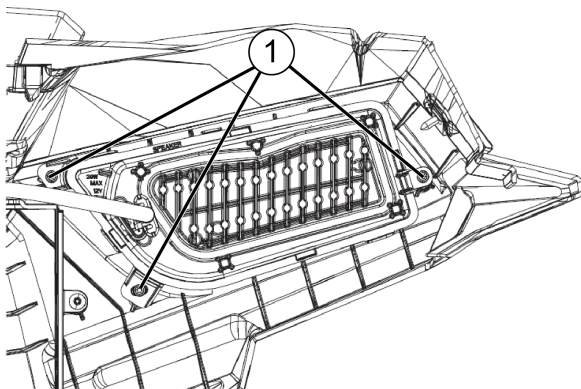

TRACTOR IMMERSION

NOTICE

If your Tractor becomes immersed, major engine damage can result if the machine is not thoroughly inspected. Take the Tractor in for service before starting the engine. Your EGIMOTORS dealer can provide this service.

If it's impossible to take your Tractor to a dealer before starting it, follow the steps outlined below.

1. Move the Tractor to dry land.
2. Check the air box. See the Air Filter section for details. If water is present, dry the air box and replace the filter with a new filter.
3. Remove the fuse/relay center cover. See the Fuse/Relay Center section for details. Allow any moisture to dry, then reinstall the cover.
4. Dry the spark plug wells with a clean cloth, then remove the spark plugs.
5. Turn the engine over several times to expel any water from the engine cylinders.
6. Dry the spark plugs and reinstall them, or install new plugs.
7. Attempt to start the engine. If necessary, repeat the drying procedure.

8. Take the Tractor in for service as soon as possible, whether you succeed in starting it or not. Your EGIMOTORS dealer can provide the required service.
9. If water has been ingested into the PVT follow the steps in the EGIMOTORS Variable Transmission (PVT) System section for drying procedures.

STEERING WHEEL INSPECTION

Check the steering wheel for specified freeplay and smooth operation at the intervals outlined in the Periodic Maintenance Chart.

1. Position the Tractor on level ground.
2. Lightly turn the steering wheel left and right.
3. There should be 20-25 mm of freeplay.
4. If there is excessive freeplay or strange noises, or if the steering feels rough or “catchy,” have the steering system inspected by an authorized EGIMOTORS dealer or other qualified personnel.

BATTERY

WARNING

Improperly connecting or disconnecting battery cables can result in an explosion and cause serious injury or death. When removing the battery, always disconnect the negative (black) cable first. When reinstalling the battery, always connect the negative (black) cable last.

Your Tractor has a low-maintenance battery. Always keep battery terminals and connections free of corrosion. If cleaning is necessary, remove the corrosion with a stiff wire brush. Wash with a solution of one tablespoon baking soda and one cup water. Rinse well with tap water and dry off with clean shop towels. Coat the terminals with dielectric grease or petroleum jelly.

BATTERY REMOVAL

1. Access the battery via the front underhood storage.
2. Disconnect the black (negative) battery cable first.
3. Disconnect the red (positive) battery cable last.
4. Remove the battery hold-down strap.
5. Lift the battery out of the Tractor.

BATTERY INSTALLATION

Using a new battery that has not been fully charged can damage the battery and result in a shorter life. It can also hinder Tractor performance. Follow the battery charging instructions in the AGM Battery Maintenance and Charging section before installing the battery.

1. Ensure that the battery is fully charged.
2. Place the battery in the battery holder.
3. Coat the terminals with dielectric grease or petroleum jelly.
4. Secure the battery hold-down strap.
5. Connect and tighten the red (positive) cable first.
6. Connect and tighten the black (negative) cable last.
7. Verify that cables are properly routed.

BATTERY MAINTENANCE AND CHARGING

⚠ WARNING

An overheated battery may explode, causing severe injury or death. Always watch charging times carefully. Stop charging if the battery becomes very warm to the touch. Allow it to cool before resuming charging.

The sealed battery is already filled with electrolyte and has been sealed and *fully charged* at the factory. *Never* pry the sealing strip off or add any other fluid to this battery.

The single most important thing about maintaining a sealed battery is to keep it fully charged. Check the battery voltage with a voltmeter or multimeter. A fully charged battery will register 12.8 V or higher. If the voltage falls below 12.5V, charge it immediately, or the battery runs the risk of sulfation and reduced battery life.

If you do not drive the Tractor for more than TWO WEEKS, Egimotors recommends using a BatteryMINDER® 2012 AGM - 2 AMP charger (PN 2830438), which can be ordered through your dealer.

Egimotors provides a charging accessory with your Tractor that allows easy connection to the battery through the 12V auxiliary outlet, located on the dash. During charging, place the charger outside of the Tractor and protect it from moisture.

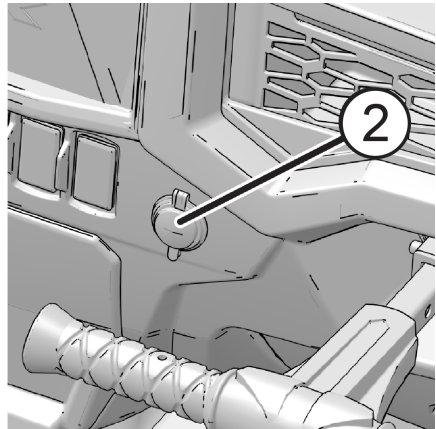
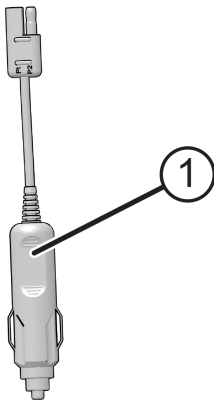

If you plan to store the Tractor for ONE MONTH or longer, remove the battery from the Tractor, then store the battery in a cool and dry location. Continue to maintain the battery with the BatteryMINDER® 2012 AGM - 2 AMP charger.

When using an automatic charger other than a BatteryMINDER® 2012-AGM - 2 AMP charger, refer to the charger manufacturer's instructions for recharging.

If using a **constant current charger** (instead of BatteryMINDer® 2012 AGM - 2 AMP charger), use the guidelines below. Always verify battery condition before and 1-2 hours after the end of charging.

State of Charge	Voltage (DC)	Action	Charge Time*
100%	12.8-13.0 volts	None, check monthly	None required
75%-100%	12.6-12.8 volts	May need slight charge, if no charge given, check in 2 weeks	3-6 hours
50%-75%	12.3-12.6 volts	Needs charge	5-11 hours
25%-50%	12.0-12.3 volts	Needs charge	At least 13 hours
0%-25%	12.0 volts or less	Needs charge	At least 20 hours

* Using AGM specific charger at standard amps specified on top of battery

CLEANING AND STORAGE

WASHING THE TRACTOR

Keeping your EGIMOTORS Tractor clean will not only improve its appearance but it can also extend the life of various components.

NOTICE

Water in the PVT system could cause the drive belt to become wet and slip in the clutches. Always avoid spraying water directly toward any intake pre-filtersq.

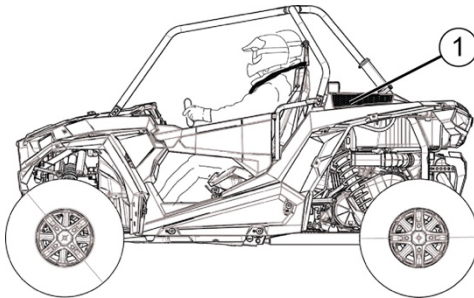

High water pressure may damage radiator fins and impair a radiator's effectiveness. High pressure may also damage other Tractor components.

Certain products, including insect repellents and chemicals, will damage plastic surfaces. Do not allow these types of products to contact the Tractor.

The best and safest way to clean your EGIMOTORS Tractor is with a garden hose and a pail of mild soap and water.

1. Use a professional-type washing cloth, cleaning the upper body first and the lower parts last.
2. Rinse with clean water frequently.
3. Dry surfaces with a chamois to prevent water spots.

If a high pressure water system is used for cleaning (not recommended), exercise extreme caution. The water may damage components and could remove paint and labels. Avoid directing the water stream at the following items:

- Wheel bearings
- Radiators
- Turbo wastegate actuator and linkage

-
- Transmission seals
 - Brakes
 - Cab and body panels
 - Labels and decals
 - Electrical components and wiring
 - Air intake components

If warning and safety labels are damaged, contact your EGIMOTORS dealer for free replacement.

Grease all zerk fittings immediately after washing. Allow the engine to run for a while to evaporate any water that may have entered the engine or exhaust system.

WASHING TIPS

- Avoid the use of harsh cleaners, which can scratch the finish.
- Do not use a power washer to clean the Tractor.
- Do not use medium to heavy duty compounds on the finish.
- Always use clean cloths and pads for cleaning and polishing. Old or reused cloths and pads may contain dirt particles that will scratch the finish.
- Be sure to clean the Tractor's *spray suppression valances* on the front and rear.

POLISHING THE TRACTOR

EGIMOTORS recommends the use of common household aerosol furniture polish for polishing the finish on your EGIMOTORS Tractor. Follow the instructions on the container.

POLISHING TIPS

- Avoid the use of automotive products, some of which can scratch the finish of your Tractor.
- Always use clean cloths and pads for cleaning and polishing. Old or reused cloths and pads may contain dirt particles that will scratch the finish.
- Avoid the use of products containing a colorant dye. Test any products on an inconspicuous area of the Tractor before using throughout.

STORAGE TIPS

NOTICE

Starting the engine during the storage period will disturb the protective film created by fogging and damage could occur. Never start the engine during the storage period.

CLEAN THE EXTERIOR

Make any necessary repairs and clean the Tractor as recommended. See the Washing the Tractor section for details.

STABILIZE THE FUEL

1. Fill the fuel tank.
2. Add EGIMOTORS Carbon Clean Fuel Treatment or EGIMOTORS Fuel Stabilizer or equivalent fuel treatments or stabilizers. Follow the instructions on the container for the recommended amount. Carbon Clean removes water from fuel systems, stabilizes fuel and removes carbon deposits from pistons, rings, valves and exhaust systems.
3. Allow the engine to run for 15-20 minutes to allow the stabilizer to disperse through the entire fuel delivery system.

OIL AND FILTER

Change the oil and filter. See the Oil and Filter Change section for details.

AIR FILTER / AIR BOX

Replace the air filter. See the Air Filter section for details. Clean the air box.

FLUID LEVELS

Inspect the fluid levels. Add or change fluids as recommended in the Periodic Maintenance Chart.

- Demand drive fluid (front gearcase)
- Rear gearcase fluid (if equipped)
- Transmission fluid
- Brake fluid (change every two years and any time the fluid looks dark or contaminated)
- Coolant (test strength/fill)

INSPECT AND LUBRICATE

Inspect all cables and lubricate all areas of the Tractor as recommended in the Periodic Maintenance Chart.

FOG THE ENGINE

1. Treat the fuel system with EGIMOTORS Carbon Clean or other equivalent fuel treatment. Follow the instructions on the container. Start the engine. Allow it to idle for several minutes so the Carbon Clean reaches the injectors. Stop the engine.
2. Remove the spark plugs and add 2-3 tablespoons of engine oil. To access the plug holes, use a section of clear 1/4 in (6.35 mm) hose and a small plastic squeeze bottle filled with the pre-measured amount of oil. *Do this carefully! If you miss the plug holes, oil will drain from the spark plug cavities into the hole at the front of the cylinder head, and appear to be an oil leak.*
3. Reinstall the spark plugs. Torque to specification. See the Spark Plug Gap / Torque section for details.
4. Apply dielectric grease to the inside of each spark plug cap. *Do not reinstall the caps onto the plugs at this step.*
5. Turn the engine over several times. Oil will be forced in and around the piston rings and ring lands, coating the cylinder with a protective film of fresh oil.
6. If EGIMOTORS fuel system additive is not used, fuel tank, fuel lines, and injectors should be completely drained of gasoline.
7. Reinstall the spark plug caps to the spark plugs.

STORAGE AREA / COVERS

Be sure the storage area is well ventilated. Cover the Tractor with a genuine EGIMOTORS cover. Do not use plastic or coated materials. They do not allow enough ventilation to prevent condensation, and may promote corrosion and oxidation.

REMOVAL FROM STORAGE

WARNING

Engine exhaust contains poisonous carbon monoxide and can cause loss of consciousness or death. Never run an engine in an enclosed area.

1. Charge the battery if necessary.
2. Make sure the spark plug is tight. Reinstall the fuse box cover if it was removed for storage.
3. Fill the fuel tank with fuel.
4. Check all the points listed in the Daily Pre-Ride Inspection section. Tightness of the bolts, nuts and other fasteners should be checked by an authorized EGIMOTORS dealer or other qualified service facility.

SPECIFICATIONS

SPECIFICATIONS

RZR XP 4 1000 TRACTOR

Dry Weight estimated	724 kg
Rear Hitch Tongue Capacity	85 Kg
Rear Hitch Towing Capacity	900 kg on the level ground
Rear Cargo Box Capacity	136 kg
Maximum Weight Capacity (Payload) including accessory	408 kg
Maximum Braked Trailer Mass	900 kg
Unbraked Trailer Towing Capacity	390 kg
Fuel Capacity	36 liters
Engine Oil Capacity	2.4 liters
Coolant Capacity	5.1 liters
Demand Drive Fluid Capacity	251 ml
Transmission Oil Capacity	1.3 liters Turf Models: 1.2 L
Overall Length/Width/Height	370 /162 /187 cm
Wheelbase	297 cm
Ground Clearance	34.3 cm
Engine	4-Stroke DOHC Twin Cylinder
Displacement	999 cc

SPECIFICATIONS

Bore x Stroke	93mm x 73.5mm
Alternator Output	560 W @ 3000 RPM
Compression Ratio	11.0:1
Starting System	Electric
Fuel System	Electronic fuel injection
Ignition System	ECU
Spark Plug / Gap	NGK® MR7F 0.7-0.8 mm
Front Suspension	Independent double a-arm with 40.6 cm travel
Rear Suspension	Independent trailing arms with 45.7 cm travel
Lubrication System	Wet Sump
Driving System Type	Automatic Variable Transmission
Shift Type	P/R/N/L/H
Tire Size - Front	29x9-14
Tire Size - Rear	29x11-14
Tire Pressure BAR	Light Load : Front - 1,3 Rear - 1,4 Heavy Load : Front – 1,6 Rear – 1,8
Brakes, Front/Rear	Foot Activated, 4-wheel hydraulic disc
Headlights	2 dual beam LED cluster
Taillights	2 LED cluster
Brake Lights	2 LED cluster
Instrument Cluster	Analog and LCD

LUBRICANTS / SERVICE PRODUCTS

PART NUMBER	DESCRIPTION
Engine Lubricant	
2870791	Fogging Oil — 12 fl oz (355 mL) Aerosol
2876244	PS-4 Full Synthetic 5W-50 4-Cycle Oil — 1 qt (0.95 L)
2876245	PS-4 Full Synthetic 5W-50 4-Cycle Oil — 1 gal (3.8 L)
2878920	PS-4 Extreme Duty Synthetic 10W-50 4-Cycle Oil — 1 qt (0.95 L)
2878919	PS-4 Extreme Duty Synthetic 10W-50 4-Cycle Oil — 1 gal (3.8 L)
Gearcase / Transmission Lubricants	
2878068	AGL Full Synthetic Gearcase Lubricant & Transmission Fluid — 1 qt (0.95 L)
2878069	AGL Full Synthetic Gearcase Lubricant & Transmission Fluid — 1 gal (3.8 L)
2877922	Demand Drive Fluid — 1 qt (0.95 L)
2877923	Demand Drive Fluid — 1 gal (3.8 L)
2870465	Pump for 1 gal (3.8 L) Jug
Coolant	
2880514	Antifreeze 50/50 Premix — 1 qt (0.95 L)
2880513	Antifreeze 50/50 Premix — 1 gal (3.8 L)
Grease / Specialized Lubricants	
2871312	Grease Gun Kit, All Season Grease
2871322	All Season Grease — 3 fl oz (89 mL) Cartridge
2871423	All Season Grease — 14 fl oz (414 mL) Cartridge
2876160	ATV Angle Drive Fluid — 1 qt (0.95 L)

PART NUMBER	DESCRIPTION
2872276	ATV Angle Drive Fluid — 2.5 gal (9.5 L)
2871460	Premium Starter Grease
2871515	U-Joint Grease — 3 fl oz (89 mL) Cartridge
2871551	U-Joint Grease — 14 fl oz (414 mL) Cartridge
2871329	Dielectric Grease (Nyogel®)
Additives / Miscellaneous	
2871326	Carbon Clean
2870652	Fuel Stabilizer
2872189	DOT 4 Brake Fluid
2871956	Loctite® 565 Thread Sealant
2830438	EGIMOTORS Battery Trickle Charger

TROUBLESHOOTING

DRIVE BELT WEAR / BURN

POSSIBLE CAUSE	SOLUTION
Driving onto a pickup or tall trailer in high range	Use low range during loading.
Starting out going up a steep incline	Use low range. See the Low Range section for details.
Driving at low RPM or ground speed 3-7 mph (5-11 km/h)	Drive at a higher speed or use low range more frequently. See the Low Range section for details.
Insufficient warm-up at low ambient temperatures	Warm the engine at least 5 minutes. With the transmission in neutral, advance the throttle to about 1/8 throttle in short bursts, 5 to 7 times. The belt will become more flexible and prevent belt burning.
Slow/easy clutch engagement	Use the throttle quickly and effectively.
Hauling heavy cargo/pushing at low RPM/low ground speed	Use low range only.
Utility use/plowing	Use low range only.
Stuck in mud or snow	Shift the transmission to low range and carefully use fast, aggressive throttle application to engage clutch. WARNING! Excessive throttle may cause loss of control and Tractor rollover.
Climbing over large objects from a stopped position	Shift the transmission to low range and carefully use fast, brief, aggressive throttle application to engage clutch. WARNING! Excessive throttle may cause loss of control and Tractor rollover.
Belt slippage from water or snow ingestion into the PVT system	Dry out the PVT. Prevent water from entering the PVT outlet duct (see the Washing the Tractor section for details). Inspect clutch seals for damage if repeated leaking occurs.
Clutch malfunction	See your dealer.

TROUBLESHOOTING

POSSIBLE CAUSE	SOLUTION
Poor engine performance	Check for fouled plugs or foreign material in gas tank or fuel lines. See your dealer.
Slippage from failure to warm up belt	Always warm up the belt by operating below 30 mph (48 km/h) for 1 miles (1.5 km) and for 5 miles (8 km) or more when temperature is below freezing.
Wrong or missing belt	Install the recommended belt.
Improper break-in	Always break in a new belt and/or clutch. See the Tractor Break-in Period section for details.
Failed belt	Remove the belt and clean away any debris from the clutch box, clutch duct and engine compartment. Install a new belt. WARNING! Failure to remove ALL debris when replacing the belt could result in Tractor damage and severe injury or death. See the Belt Replacement / Debris Removal section for details.

ENGINE DOESN'T TURN OVER

POSSIBLE CAUSE	SOLUTION
Low battery voltage	Recharge the battery to 12.8 VDC
Loose battery connections	Check all connections and tighten
Loose solenoid connections	Check all connections and tighten
Loose electronic control box connections	Inspect, clean, reinstall connectors
Mechanical failure	See your dealer

ENGINE TURNS OVER, FAILS TO START

POSSIBLE CAUSE	SOLUTION
Out of fuel	Refuel
Clogged fuel filter	See your dealer
Water is present in fuel	Drain the fuel system and refuel
Old or non-recommended fuel	Replace with fresh recommended fuel
Fouled or defective spark plugs	Inspect plugs and replace if necessary
No spark to spark plug	Inspect plugs and replace if necessary
Water or fuel in crankcase	Immediately see your dealer
Low battery voltage	Recharge the battery to 12.8 VDC
Loose ignition connections	Check all connections and tighten
Mechanical failure	See your dealer

ENGINE BACKFIRES

POSSIBLE CAUSE	SOLUTION
Out of fuel	Refuel
Weak spark from spark plug	Inspect, clean and/or replace spark plugs
Incorrect spark plug gap or heat range	Set gap to specs or replace plugs
Old or non-recommended fuel	Replace with fresh recommended fuel
Incorrectly installed spark plug wires	See your dealer
Incorrect ignition timing	See your dealer
Loose ignition connections	Check all connections and tighten
Water present in fuel	Replace with fresh recommended fuel

TROUBLESHOOTING

POSSIBLE CAUSE	SOLUTION
Exhaust leak	Check all connections
Mechanical failure	See your dealer

ENGINE PINGS OR KNOCKS

POSSIBLE CAUSE	SOLUTION
Poor quality or low octane fuel	Replace with recommended fuel
Incorrect ignition timing	See your dealer
Incorrect spark plug gap or heat range	Set gap to specs or replace plugs

ENGINE RUNS IRREGULARLY, STALLS, OR MISFIRES

POSSIBLE CAUSE	SOLUTION
Fouled or defective spark plugs	Inspect, clean and/or replace spark plugs
Worn or defective spark plug wires	Your EGIMOTORS dealer or qualified person can assist
Incorrect spark plug gap or heat range	Set gap to specs or replace plugs
Loose ignition connections	Check all connections and tighten
Water present in fuel	Replace with new fuel
Low battery voltage	Recharge battery to 12.8 VDC
Kinked or plugged fuel tank vent line or filter	Inspect and replace
Kinked idle air control lines	Inspect; rotate lines to remove kink
Incorrect fuel	Replace with recommended fuel
Clogged air filter	Inspect and replace clogged/wet air filter, and also check for obstructed intake system, debris or cargo blocking intake vents

TROUBLESHOOTING

POSSIBLE CAUSE	SOLUTION
Clogged intake pre-filter	Inspect and clean (with soapy water) or replace
Other mechanical failure	See your dealer

POSSIBLE LEAN FUEL CAUSE	SOLUTION
Low or contaminated fuel	Add or change fuel, clean the fuel system
Low octane fuel	Replace with recommended fuel
Clogged fuel filter	See your dealer
Low fuel pressure	See your dealer

ENGINE STOPS OR LOSES POWER

POSSIBLE CAUSE	SOLUTION
Out of fuel	Refuel
Kinked or plugged fuel tank vent line or filter	Inspect and replace
Water is present in fuel	Replace with new fuel
Fouled or defective spark plugs	Inspect, clean and/or replace spark plug
Worn or defective spark plug wires	See your dealer
Incorrect spark plug gap or heat range	Set gap to specs or replace plug
Loose ignition connections	Check all connections and tighten
Low battery voltage	Recharge the battery to 12.8 VDC
Incorrect fuel	Replace with fresh recommended fuel
Clogged air filter	Inspect and replace clogged/wet air filter, and also check for obstructed intake system, debris or cargo blocking intake vents

WARRANTY

LIMITED WARRANTY

This warranty covers parts and labor charges for repair or replacement of defective parts and begins on the date of purchase by the original retail purchaser. This warranty is transferable to another owner during the warranty period through a EGIMOTORS dealer, but any such transfer will not extend the original term of the warranty. The duration of this warranty may vary by international region based upon local laws and regulations.

REGISTRATION

At the time of sale, the Warranty Registration Form must be completed by your dealer and submitted to EGIMOTORS within ten days of purchase. Upon receipt of this registration, EGIMOTORS will record the registration for warranty. No verification of registration will be sent to the purchaser as the copy of the Warranty Registration Form will be your proof of warranty coverage. If you have not signed the original registration and received the customer copy, please contact your dealer immediately. **NO WARRANTY COVERAGE WILL BE ALLOWED UNLESS YOUR TRACTOR IS REGISTERED WITH POLARIS.**
Initial

dealer preparation and set-up of your Tractor is very important in ensuring trouble-free operation. Purchasing a machine in the crate or without proper dealer set-up will void your warranty coverage.

WARRANTY

WARRANTY COVERAGE AND EXCLUSIONS

LIMITATIONS OF WARRANTIES AND REMEDIES

This EGIMOTORS limited warranty excludes any failures that are not caused by a defect in material or workmanship. THIS WARRANTY DOES NOT COVER CLAIMS OF DEFECTIVE DESIGN. This warranty also does not cover acts of God, accidental damage, normal wear and tear, abuse or improper handling. This warranty also does not cover any Tractor, component, or part that has been altered structurally, modified, neglected, improperly maintained or used for racing, competition or purposes other than for which it was designed.

This warranty excludes damages or failures resulting from improper lubrication; improper engine timing; improper fuel; surface imperfections caused by external stress, heat, cold or contamination; operator error or abuse; improper component alignment, tension, adjustment or altitude compensation; snow, water, dirt or other foreign substance ingestion/contamination; improper maintenance; modified components; use of aftermarket or unapproved components, accessories, or attachments; unauthorized repairs; or repairs made after the warranty period expires or by an unauthorized repair center.

This warranty excludes damages or failures caused by abuse, accident, fire, or any other cause other than a defect in materials or workmanship and provides no coverage for consumable components, general wear items, or any parts exposed to friction surfaces, stresses, environmental conditions and/or contamination for which they were not designed or not intended, including but not limited to the following items:

- Wheels and tires
- Suspension components
- Brake components
- Seat components
- Clutches and components
- Steering components
- Batteries
- Light bulbs/Sealed beam lamps
- Filters
- Lubricants
- Bushings
- Finished and unfinished surfaces
- Carburetor/Throttle body components
- Engine components
- Drive belts
- Hydraulic components and fluids
- Circuit breakers/Fuses
- Electronic components
- Spark plugs
- Sealants
- Coolants
- Bearings

LUBRICANTS AND FLUIDS

1. Mixing oil brands or using non-recommended oil may cause engine damage. We recommend the use of Polaris engine oil.
2. Damage or failure resulting from the use of non-recommended lubricants or fluids is not covered by this warranty.

This warranty provides no coverage for personal loss or expense, including mileage, transportation costs, hotels, meals, shipping or handling fees, product pick-up or delivery, replacement rentals, loss of product use, loss of profits, or loss of vacation or personal time.

THE EXCLUSIVE REMEDY FOR BREACH OF THIS WARRANTY SHALL BE, AT POLARIS' OPTION, REPAIR OR REPLACEMENT OF ANY DEFECTIVE MATERIALS, COMPONENTS, OR PRODUCTS. THE REMEDIES SET FORTH IN THIS WARRANTY ARE THE ONLY REMEDIES AVAILABLE TO ANY PERSON FOR BREACH OF THIS WARRANTY. EGIMOTORS SHALL HAVE NO LIABILITY TO ANY PERSON FOR INCIDENTAL, CONSEQUENTIAL OR SPECIAL DAMAGES OF ANY DESCRIPTION, WHETHER ARISING OUT OF EXPRESS OR IMPLIED WARRANTY OR ANY OTHER CONTRACT, NEGLIGENCE, OR OTHER TORT OR OTHERWISE. THIS EXCLUSION OF CONSEQUENTIAL, INCIDENTAL, AND SPECIAL DAMAGES IS INDEPENDENT FROM AND SHALL SURVIVE ANY FINDING THAT THE EXCLUSIVE REMEDY FAILED OF ITS ESSENTIAL PURPOSE.

THE IMPLIED WARRANTY OF FITNESS FOR A PARTICULAR PURPOSE IS EXCLUDED FROM THIS LIMITED WARRANTY. ALL OTHER IMPLIED WARRANTIES (INCLUDING BUT NOT LIMITED TO THE IMPLIED WARRANTY OF MERCHANTABILITY) ARE LIMITED IN DURATION TO THE ABOVE SIX MONTH WARRANTY PERIOD. EGIMOTORS DISCLAIMS ALL EXPRESS WARRANTIES NOT STATED IN THIS WARRANTY. SOME STATES DO NOT PERMIT THE EXCLUSION OR LIMITATION OF INCIDENTAL OR CONSEQUENTIAL DAMAGES OR ALLOW LIMITATIONS ON THE DURATION OF IMPLIED WARRANTIES, SO THE ABOVE LIMITATIONS MAY NOT APPLY TO YOU IF INCONSISTENT WITH CONTROLLING STATE LAW.

WARRANTY

HOW TO OBTAIN WARRANTY SERVICE

If your Tractor requires warranty service, you must take it to a EGIMOTORS Servicing Dealer. When requesting warranty service you must present your copy of the Warranty Registration Form to the dealer. (THE COST OF TRANSPORTATION TO AND FROM THE DEALER IS YOUR RESPONSIBILITY.) EGIMOTORS suggests that you use your original selling dealer; however, you may use any EGIMOTORS Servicing Dealer to perform warranty service.

In the Country where your product was purchased:

Warranty or Service Bulletin repairs must be done by an authorized EGIMOTORS dealer. If you move or are traveling within the country where your product was purchased, Warranty and Service Bulletin repairs may be requested from any authorized EGIMOTORS dealer that sells the same line as your product.

Outside the Country where your product was purchased:

If you are traveling temporarily outside the country where your product was purchased, you should take your product to an authorized EGIMOTORS dealer. You must show the dealer photo identification from the country of the selling dealer's authorized location as proof of residence. Upon residence verification, the servicing dealer will be authorized to perform the warranty repair.

If you move:

If you move to another country, be sure to contact EGIMOTORS Customer Assistance and the customs department of the destination country before you move. Product importation rules vary considerably from country to country. You may be required to present documentation of your move to EGIMOTORS in order to continue your warranty coverage. You may also be required to obtain documentation from EGIMOTORS in order to register your product in your new country. You should warranty register your product at a local EGIMOTORS dealer in your new country immediately after you move to continue your warranty coverage and to ensure that you receive information and notices regarding your Tractor.

If you purchase from a private party:

If you purchase a EGIMOTORS product from a private party, to be kept and used outside of the country in which the product was originally purchased, all warranty coverage will be denied. You must nonetheless register your product under your name and address with a local EGIMOTORS dealer in your country to ensure that you receive safety information and notices regarding your product.

EXPORTED PRODUCTS

EXCEPT WHERE SPECIFICALLY REQUIRED BY LAW, THERE IS NO WARRANTY OR SERVICE BULLETIN COVERAGE ON THIS PRODUCT IF IT IS SOLD OUTSIDE THE COUNTRY OF THE SELLING DEALER'S AUTHORIZED LOCATION. This policy does not apply to products that have received authorization for export from POLARIS. Dealers may not give authorization for export. You should consult an authorized dealer to determine this product's warranty or service coverage if you have any questions. This policy does not apply to products registered to government officials or military personnel on assignment outside the country of the selling dealer's authorized location. This policy does not apply to Safety Bulletins.

NOTICE

If your product is registered outside of the country where it was purchased and you have not followed the procedure set above, your product will no longer be eligible for warranty or service bulletin coverage of any kind, other than safety bulletins. Products registered to government officials or military personnel on assignment outside of the country where the product was purchased will continue to be covered by the Limited Warranty.

This warranty gives you specific legal rights, and you may also have other rights which vary from state to state or in different countries. If any of the above terms are void because of federal, state, local law, all other warranty terms will remain in effect.

Tractor Certificate of Pre-Delivery

Year _____ Model _____

VIN _____

Engine Serial Number _____

Key Number _____ Km / Hours _____

Registration Plate Number _____

ASSEMBLY / SERVICE / INSPECTION

- SEALED BATTERY – Apply dielectric grease to terminal bolts and install cable. Check Voltage and charge if below 12.8 Volts.
- BATTERY VOLTAGE – Misuse and record the battery voltage after 30 minutes after charger has been removed _____ DCV
- TIRE PRESSURE – Verify Pressure if set to Specification
- WHEEL NUT – Torque to specification
- HANDLEBAR CLAMPS - Torque bolts to specification
- MASTER CYLINDER – Torque bolts to specification
- FRONT TOE ALIGNMENT – Verify proper toe setting
- BALL JOINT – Inspect bolts and/or cotter pin
- STEERING POST – Inspect cotter pin
- TIE ROD – Inspect jam nuts and cotter pin
- TRANSMISSION – Add oil if needed
- GREASE FITTING – Check and Grease all the Fitting if needed
- ENGINE OIL – Check level of oil, add if needed
- BRAKE FLUID – Check level of fluid, add if needed in brake master cylinder(s)
- ENGINE COOLANT – Inspect coolant in recovery bottle. Add if needed.
- PARK BRAKE – Verify proper operation
- INTAKE AIRBOX – Inspect hose connection and clamps. Inspect filter condition.
- LIGHTS – Verify operation of all lights
- FUEL – Check level of fuel and add if needed
- WIRE HARNESS / HOSE/ LINES – Inspect wire, hoses, and line from kinks, pinching and sign of abrasion.
- UNIT INQUIRY – Check in the system and complete applicable Service Bulletins Recalls or factory direct modification(s)
- COSMETIC INSPECTION – Inspect the quadricycle for damage and proper fit and finish.

DEALERSHIP NAME _____ # _____

ASSEMBLED BY _____

DATE _____ / _____ / _____

SIGNATURE

STAMP

Tractor Certificate of Pre-Delivery

Year _____ Model _____

VIN _____

Engine Serial Number _____

Key Number _____ Km / Hours _____

Registration Plate Number _____

TEST RIDE

- ENGINE – Starting acceleration and smoothness.
- IDLE SPEED – Verify when cold and hot the engine idle properly.
- TROTTLE – With engine idling and transmission in Neutral, swing the handlebar through entire travel range and verify proper and smooth operation.
- ETC - Verify proper operation and throttle free play.
- AUXILIARY SHUT OFF SWITCH - Verify proper operation.
- BRAKES - Verify proper operation. Torque bolts to specification
- DRIVELINE – Verify smooth operation
- CLUTCH / TRANSMISSION – Verify proper shifting and transmission engagement/ indicator lights must correspond with gears.
- AWD ADC – Verify proper operation.
- REVERSE SPEED LIMITER – Verify operation and override control.
- INSTRUMENTATION – Verify operational reading.
- WHINCH (If equipped) – Verify proper operation.
- SUSPENSION / STEERING – Verify adjustment, stability and operation.
- ENGINE COOLANT Inspect coolant in recovery bottle between Min and Max after test ride, add if necessary.
- DIAGNOSTIC SYSTEM – Run Engine up to full operating temperature. Use digital Wrench to generate and submit a “Service Report” recommended Process.
- LEAKAGE – After completing “Diagnostic System” check for leakage and verify proper connection of oil / exhaust / fuel / Coolant / Brake fluid fitting, inspect hoses for sign and abrasion.
- CLEAN – Wash and clean the quadricycle before delivery.

TEST RIDDEN BY _____

DATE _____ / _____ / _____

SIGNATURE

STAMP

Tractor Certificate of Pre-Delivery

Year _____ Model _____

VIN _____

Engine Serial Number _____

Key Number _____ Km / Hours _____

Registration Plate Number _____

DELIVERY TO CUSTOMER

- WARRANTY REGISTRATION FORM – Completed and signed.
- OWNERS MANUAL – Emphasize the importance of reading for customer Safety and Servicing of Quadricycle/ Explain periodic maintenance responsibilities.
- WARRANTY POLICY – Explanation / Limit / Requirements.
- KEYS - Record Key Number.
- Controls – Show location and function.
- BELT LIFE – Discuss proper operation procedure operating and proper use of High and Low Gear Range.
- BREAK IN PROCEDURE – Review as outline in Owner’s Manual.
- STORAGE / FUELING / TRANSPORTATION – Review as outline in the owner’s manual.
- TOOL KIT – Show location.
- Safety Video – Review with Customer.
- SAFETY FEATURES – Review all safety features of quadricycle operation for new operation.
- DRIVING PROCEDURE – Review Operator driving procedure outlined in the Owner’s Manual.
- SVIA TRAINING FACT SHEET – Review with customer.
- SAFETY TRAINING COURSE SVIA – I have instructed the owner on the authorized SVIA Safety training online course.
- PRE-DELIVERY CERTIFICATION – I certify that pre-delivery inspection and service have been perform on this vehicle in accordance with the instructions issued by Egimotors.

DEALERSHIP NAME _____ # _____

DELIVERED BY _____

DATE _____ / _____ / _____

SIGNATURE

STAMP

Tractor Certificate of Pre-Delivery

Year _____ Model _____

VIN _____

Engine Serial Number _____

Key Number _____ Km / Hours _____

Registration Plate Number _____

CUSTOMER ACCEPTANCE

- I have reviewed the Egimotors warranty Policy / Policies
- I have inspected the Quadricycle and it meets my satisfaction.
- I understand the importance of following the Owner's Manual and instructions.
- I understand the importance of using all safety features.

Review with customer.

- I understand the importance of all operation following the operator driving procedures in the Owner's Manual.
- I have been instructed on the authorized online SVIA training course by my Dealer _____
(Name of dealership and person who inform the Customer)

CUSTOMER NAME _____

CUSTOMER SIGNATURE

DATE _____ / _____ / _____

Egimotors

Via Filippo da Desio 49/51
20832 Desio (MB) ITALY

info@polarisitalia.com

For more informations
visit www.Egimotors.it

