

Egimotors

2024

OWNER'S MANUAL

TRACTOR

RANGER CREW XP 1000

Owner's manual part Number - OM24TRGCXP1000

Read this manual carefully. It contains important safety information. This is an adult Tractor only.

Operation is prohibited for those under 18 years of age.

 **WARNING**

This Owner Manual refers to EGIMOTORS TRACTORS
(To be filled in by your Dealer)

This Owner's Manual must remain inside you Tractor
(Legal requirement)

A digital/printable copy is available on www.egimotors.it

Year _____

Model Type _____

Code number (spare parts use only) _____

VIN Number _____

Engine Serial Number _____

Personal PIN Security Code: _____

Registration Plate Number _____

Thank you for purchasing an Egimotors Tractor, and welcome to our world-wide family of enthusiasts.

We have done This manual to inform you on how to use and maintain the best condition of operation for your Tractor.

If after reading this manual, you still have some questions please do not hesitate to contact your dealer that will be available to help you.

Be sure to visit us online at www.Egimotors.it for the latest news and for product and Safety information.

We believe we sets a standard of excellence for all utility and Tractor manufactured in the world today.

Many years of experience have gone into the engineering, design, and development of your Tractor, making it the finest machine we've ever produced.

For safe and enjoyable operation of your Tractor, be sure to follow the instructions and recommendations in this owner's manual.

Your manual contains instructions for the maintenance of the Tractor and information about repairs.

Service Manual are available from Dealers, only them can perform major repair and install accessory.

Your dealer knows your Tractor better than anyone and is interested in your total satisfaction, he can perform your service needs during and after the warranty period.

For the most up-to-date owner's manual visit:

<http://egimotors.it/libretto-uso-manutenzione/>

Read and understand this Owner's Manual is extremely important for your safety and for all the operators, so please take your time to read all the pages and be sure that is someone else will use the Tractor before will take this manual and read and understand all, this will give you the best knowledge and skills on how to ride in security.

All the information contained within this publication is based on the latest product information at the time of publication.

Due to constant improvement in the design and quality of product components, some minor discrepancies may result between the actual unit and the information presented in this publication.

Descriptions and or procedure in this publication are intended for reference use only. No Liability can be accepted for omission or inaccuracies. Any reprinting or reuse of the depictions and or procedures contained within this publication are intended for reference use only. The original instruction is in English.

Other languages are provided as translation of the original Instruction see the Egimotors website for more details and procedure

WELCOME

Introduction
Safety
Features and Controls
Operation
Emission Control Systems
Maintenance
Specifications
Products
Troubleshooting
Warranty
Maintenance Log
Certificate of Pre-Delivery

INTRODUCTION

BEFORE YOU RIDE

This EGIMOTORS Tractor is an off-road Tractor. Familiarize yourself with all laws and regulations concerning the operation of this Tractor in your area.

WARNING

Failure to heed the warnings and safety precautions contained in this manual can result in severe injury or death. Your EGIMOTORS Tractor is not a toy and can be hazardous to operate. This Tractor handles differently than cars, trucks or other off-road Tractors. A collision or rollover can occur quickly, even during routine maneuvers like turning, or driving on hills or over obstacles, if you fail to take proper precautions.

- Read this owner's manual and review the safety DVD that came with your Tractor. A free extra copy of the DVD can be obtained by contacting your local EGIMOTORS dealer. Understand all safety warnings, precautions and operating procedures before operating the Tractor. Keep this manual with the Tractor.
- Never operate this Tractor without proper instruction. Take an authorized training course. See the Safety Training section for more information.
- This Tractor is an **ADULT TRACTOR ONLY**. You **MUST** be at least age 16 and have a valid driver's license to operate this Tractor.
- Always use the cab nets (or doors) while riding in this Tractor. Always keep hands, feet and all other body parts inside the Tractor at all times.
- Always wear a helmet, eye protection, gloves, long-sleeve shirt, long pants and over-the-ankle boots.
- Never operate this Tractor under the influence of drugs or alcohol, as these conditions impair judgement and reduce the operator's ability to react.
- Complete the New Operator Driving Procedures outlined in this manual. Never allow a guest to operate this Tractor until the guest has completed the New Operator Driving Procedures.
- Never permit a guest to operate this Tractor unless the guest has reviewed the owner's manual and all safety labels and has completed a safety training

INTRODUCTION

SAFETY SYMBOLS AND SIGNAL WORDS

The following signal words and symbols appear throughout this manual and on your Tractor. Your safety is involved when these words and symbols are used. Become familiar with their meanings before reading the manual.

 **DANGER**

DANGER indicates a hazardous situation which, if not avoided, WILL result in death or serious injury.

 **WARNING**

WARNING indicates a hazardous situation which, if not avoided, COULD result in death or serious injury.

 **CAUTION**

CAUTION indicates a hazardous situation which, if not avoided, COULD result in minor to moderate injury.

NOTICE

NOTICE provides key information by clarifying instructions.

IMPORTANT

IMPORTANT provides key reminders during disassembly, assembly, and inspection of components.

The Prohibition Safety Sign indicates an action NOT to take in order to avoid a hazard.



The Mandatory Action Sign indicates an action that NEEDS to be taken to avoid a hazard.



NEAR-FIELD COMMUNICATION (NFC) (IF EQUIPPED)

Some EGIMOTORS Tractors come equipped with a near-field communication (NFC) chip. The NFC chip is embedded in the EGIMOTORS emblem located at the front of the Tractor and seamlessly connects you to a digital platform of Tractor information and tools. See your dealer for more information.

IMPORTANT

Not all devices are equipped with an NFC reader. Additionally, some devices require third party applications to access NFC content. For questions regarding the NFC reader on your device, refer to the device's user manual.

On models equipped with NFC, place your smartphone directly over the POLARIS emblem to do the following:

- View Tractor-specific information
- Access your EGIMOTORS Garage
- Download and view the owner's manual
- View accessory instructions
- Watch how-to videos
- Access warranty information
- Check for service notifications



RIDE COMMAND WITH NFC

Additional NFC features are available when using the Ride Command mobile app. To access these features, do the following:

1. Download the Ride Command mobile app from the Apple App Store® or Google Play® store.
2. Create or log in to an existing account.
3. From the Ride Command mobile app home screen, select **Add Tractor**.
4. On the Tractor, tap the NFC-enabled badge with the phone to scan the Tractor.
5. Confirm information, name your Tractor, and tap add to garage.

SYSTEM REQUIREMENTS

Refer to device manufacturer's instructions to verify NFC read capability, and/or NFC-capable add-ons.

INTRODUCTION

EUROPEAN VIBRATION AND NOISE

The driver-perceived noise and hand/arm and whole body vibration levels of this machinery is measured per EN 16990.

		RANGER XP 1000 CREW
Noise	A-Weighted Sound Pressure Level at Rider's Ear	69 dB(A)
	C-Weighted Sound Pressure Level at Rider's Ear	85 dB(C)
	A-Weighted Sound Power Level	n/a
Vibration	Weighted Hand-Arm Vibration Level	0.7 m/s ²
	Weighted Seat Vibration Level	0.09 m/s ²

EUROPEAN UNION (EU) RADIO COMPLIANCE

This Tractor contains the following radio equipment or components that contain radio equipment:

Component	9200 Series Display
Component ID	RC-7
Manufacturer	EGIMOTORS Industries Inc.
*Transmitting Frequency	2402 - 2480 MHz
Max RF Transmitting PWR	0.2432 W
*Other transmitting radio frequencies may exist outside of EU markets.	

The above radio equipment is in compliance with Directive 2014/53/EU.

INTRODUCTION

TRACTOR IDENTIFICATION NUMBERS

Record your Tractor's identification numbers and key number in the spaces provided. Remove the spare key and store it in a safe place. An ignition key can be duplicated only by ordering a EGIMOTORS key blank (using your key number) and mating it with one of your existing keys. The ignition switch must be replaced if all keys are lost.

NOTICE

The images below are for reference only. Depending on model, your Tractor may differ slightly.

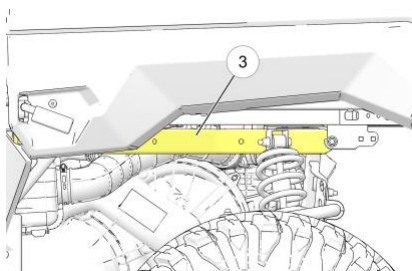
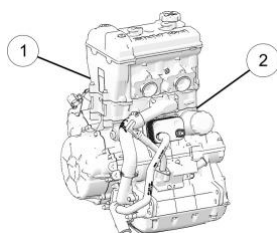

The engine serial number can be found on a decal applied to the front of the engine crankcase **q** or stamped into the crankcase on the PTO side of the engine **w**. The NRMM label can also be found in either location (if applicable).

The VIN can be found stamped on a portion of the left rear frame **e**, above the PVT cover.

Tractor Model Number:	
Tractor Identification Number (VIN):	
Engine Serial Number:	
Key Number:	

SAFETY

SAFETY TRAINING

Safety training is a top priority for EGIMOTORS. EGIMOTORS strongly encourages you and any family members who will be riding this vehicle to take a training course.

For more information about safety, contact an authorized EGIMOTORS dealer or visit the EGIMOTORS web site at www.Egimotors.com

We strongly advise you to strictly follow the recommended maintenance program outlined in your owner's manual. This preventive maintenance program is designed to ensure that all critical components on your vehicle are thoroughly inspected at specific intervals.

SAFE RIDING GEAR

Always wear a helmet, eye protection, gloves, long-sleeve shirt, long pants, over-the-ankle boots and seat belt at all times. Protective gear reduces the chance of injury.

RIDER COMFORT

Under certain operating conditions, heat generated by the engine and exhaust system can elevate temperatures in the rider cab area. The condition occurs most frequently when a vehicle is being operated in high ambient temperatures at low speeds and/or high load conditions for an extended period of time. The use of certain windshield, roof and/or cab systems may contribute to this condition by restricting airflow.

Any discomfort due to heat buildup in this area can be minimized by wearing proper riding apparel and by varying speeds to increase airflow.

Helmet

Eye Protection

Long Sleeves

Gloves

Long Pants

Over-the-Ankle Boots



SAFETY

HELMET

Wearing a helmet can prevent a severe head injury. Whenever riding this EGIMOTORS Tractor, always wear a helmet that meets or exceeds established safety standards. Clasp the buckle and pull each strap tight to ensure the helmet is properly secured to the head.

Parents and supervising adults should verify that young operators have a helmet that fits, and should obtain one of proper size if it does not fit before allowing operation.

Approved helmets in Europe, bear the ECE 22.05 label. The ECE mark consists of a circle surrounding the letter E, followed by the distinguishing number of the country which has granted approval. The approval number and serial number will also be displayed on the label.

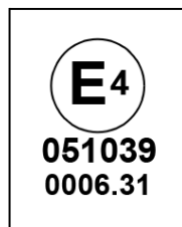

EYE PROTECTION

Do not depend on eyeglasses or sunglasses for eye protection. Whenever riding this EGIMOTORS Tractor, always wear shatterproof goggles or use a shatterproof helmet face shield. EGIMOTORS recommends wearing approved Personal Protective Equipment (PPE) bearing CE markings. Make sure protective eye wear is kept clean.

GLOVES

Wear gloves for comfort and for protection from sun, cold weather and other elements.

BOOTS

Wear sturdy over-the-ankle boots for support and protection. Never ride a EGIMOTORS Tractor with bare feet or sandals.

CLOTHING

Wear long sleeves and long pants to protect arms and legs.

SAFETY WARNINGS

 **WARNING**

Failure to operate this Tractor properly can result in a collision, loss of control, accident or rollover, which may result in serious injury or death. Heed all safety warnings outlined in this section of the owner's manual and in the safety DVD provided with your Tractor. See the OPERATION section of the owner's manual for proper operating procedures.

OPERATOR SAFETY

 **WARNING**

Serious injury or death can result if you do not follow these instructions and procedures, which are outlined in further detail within your owner's manual.

- Read this entire manual and all labels carefully. Follow the operating procedures described.
- Never allow anyone under the age of 16 to operate this Tractor and never allow anyone without a valid driver's license to operate this Tractor.
- Do not carry a passenger until you have at least two hours of driving experience with this Tractor.
- All riders must be able to sit with backs against the seat, both feet flat on the floor and both hands on the steering wheel (if driving) or on a passenger hand hold.
- The driver and all passengers must wear helmets, eye protection, gloves, long-sleeve shirts, long pants, over-the-ankle boots and their seat belts at all times.
- Always use the cab nets (or doors) while riding in this Tractor.
- Always keep hands and feet inside the Tractor at all times.
- Always keep both hands on the steering wheel and both feet on the floorboards of the Tractor during operation.
- Never permit a guest to operate this Tractor unless the guest has read this manual and all product labels.
- To reduce rollover risk, be especially careful when encountering obstacles and slopes and when braking on hills or during turns.
- This Tractor is for off road use only. Never operate on public roads (unless marked for off-road use). Always avoid paved surfaces.
- Never consume alcohol or drugs before or while operating this Tractor.
- Never operate at excessive speeds. Always travel at a speed proper for the terrain, visibility and operating conditions, and your experience.
- Never attempt jumps or other stunts.

SAFETY

- Always inspect the Tractor before each use to make sure it's in safe operating condition.
 - Always follow the inspection procedures described in this manual.
 - Always travel slowly and use extra caution when operating on unfamiliar terrain. Be alert to changing terrain.
 - Never operate on excessively rough, slippery or loose terrain.
 - Always follow proper procedures for turning. Practice turning at slow speeds before attempting to turn at faster speeds. Never turn at excessive speeds.
 - Always have this Tractor checked by an authorized EGIMOTORS dealer if it has been involved in an accident.
 - Never operate this Tractor on hills too steep for the Tractor or for your abilities. Practice on smaller hills before attempting larger hills.
 - Always follow proper procedures for climbing hills as described in this manual. Check the terrain carefully before attempting to climb a hill. Never climb hills with excessively slippery or loose surfaces. Never apply throttle suddenly. Never make sudden gear changes. Never go over the top of a hill at high speed.
 - Always follow the proper procedures outlined in this manual for traveling downhill and for braking on hills. Check the terrain carefully before descending a hill. Never travel downhill at high speed. Avoid going downhill at an angle, which would cause the Tractor to lean sharply to one side. Travel straight down the hill where possible.
 - Always check for obstacles before operating in a new area. Never attempt to operate over large obstacles such as large rocks or fallen trees. Always follow the proper procedures outlined in this manual when operating over obstacles.
 - Always be careful of skidding or sliding. On slippery surfaces such as ice, travel slowly and exercise caution to reduce the chance of skidding or sliding out of control.
 - Never operate your Tractor in fast-flowing water or in water deeper than that specified in this manual. Wet brakes may have reduced stopping ability. Test your brakes after leaving water. If necessary, apply them lightly several times to let friction dry out the pads.
 - Always be sure there are no obstacles or people behind your Tractor when operating in reverse. When it's safe to proceed in reverse, move slowly. Avoid turning at sharp angles in reverse.
 - Always use the proper size and type of tires specified in this manual. Always maintain proper tire pressure as specified on safety labels. Failure to adhere to either may impact Tractor stability, driveline durability, or general Tractor handling.
 - Never modify this Tractor through improper installation or use of non-EGIMOTORS approved accessories.
 - Always re-install plastics and heat shields after Tractor is serviced.
-

- Never exceed the stated load capacity for this Tractor. Cargo should be properly distributed and securely attached. Reduce speed and follow the instructions in this manual for hauling cargo or pulling a trailer. Allow a greater distance for braking.
- Always place the transmission in PARK before getting out of the Tractor.
- Always engage the park brake (if equipped) when leaving the Tractor unattended.
- Always stop the engine before refueling. Make sure the refueling area is well ventilated and free of any source of flame or sparks.
- Always remove the ignition key when the Tractor is not in use to prevent unauthorized use by someone under the age of 16 or without a driver's license and proper training, or accidental starting.

OPERATING WITHOUT INSTRUCTION

Operating this Tractor without proper instruction increases the risk of an accident. The operator must understand how to operate the Tractor properly in different situations and on different types of terrain.

All operators must read and understand the owner's manual and all warning and instruction labels before operating the Tractor.

All operators should review the safety DVD provided with this Tractor and take a ROHVA® training course (www.rohva.org).



AGE RESTRICTIONS

This Tractor is an ADULT TRACTOR ONLY. Operation is prohibited for anyone under 16 years of age or anyone without a valid driver's license.

The operator must be tall enough to sit with back against the seat, both feet flat on the floor and both hands on the steering wheel (if equipped) or handlebars.



SAFETY

USING ALCOHOL OR DRUGS

Never consume alcohol or drugs before or while operating this Tractor.

Operating this Tractor after consuming alcohol or drugs could adversely affect operator judgment, reaction time, balance and perception.



FAILURE TO INSPECT BEFORE OPERATING

WARNING

Failure to inspect and verify that the Tractor is in safe operating condition before operating increases the risk of an accident. Always perform the Pre-Ride Inspection outlined in the Operation chapter before each use of your Tractor to make sure it's in safe operating condition. Always follow the inspection and maintenance procedures and schedules described in this owner's manual. See the Periodic Maintenance section of the Maintenance chapter.

PROTECTIVE APPAREL

Riding in this Tractor without wearing an approved helmet and protective eyewear and footwear increases the risk of a serious injuries in the event of an accident.

Operator and/or all passengers must always wear an approved helmet that fits properly, gloves, long-sleeve shirt, long pants, over-the-ankle boots, and eye protection (goggles or face shield).

SEAT BELTS

WARNING

Riding in this Tractor without wearing the seat belt increases the risk of serious injury in the event of rollover, loss of control, other accident or sudden stop. Seat belts may reduce the severity of injury in these circumstances. The operator and all passengers **MUST** wear their seat belt at all times.

OPERATING WITH A LOAD ON THE TRACTOR

The weight of the cargo, operator, and passengers impacts Tractor operation and stability. For your safety and the safety of others, carefully consider how your Tractor is loaded and how to safely operate the Tractor. Follow the instructions in this manual for loading, tire pressure, gear selection and speed.

- **Do not exceed Tractor weight capacities.** The Tractor's maximum weight capacity is listed in the specifications section of this manual and on a label on the Tractor. When determining the weight you are adding to the Tractor, include the weight of the operator, passengers, accessories, loads in the rack or box and the load on the trailer tongue. The combined weight of these items must not exceed the maximum weight capacity.
- The recommended tire pressures are listed in the specifications section of this manual and on a label on the Tractor.

Always follow these guidelines:

UNDER ANY OF THESE CONDITIONS:	DO ALL OF THESE STEPS:
Operator and/or cargo exceeds half the maximum weight capacity	<ol style="list-style-type: none"> 1. Slow down. 2. Verify tire pressure. 3. Use extra caution when operating.
Operating in rough terrain	
Operating over obstacles	
Climbing an incline	
Towing	

CAB NETS (IF EQUIPPED)

Riding in this Tractor without using the cab nets (or doors, if equipped) increases the risk of serious injury or death in the event of an accident or rollover. Cab nets (or doors) must be used by both operator and passengers at all times. Make sure all latches are secure before operating the Tractor.

Always inspect cab nets and latches for tightness, wear and damage before each use of the Tractor. Use the strap adjusters to tighten any loose straps. Promptly replace worn or damaged cab nets and latches with new cab nets and latches. Your EGIMOTORS dealer can assist.

CAB DOORS (IF EQUIPPED)

Riding in this Tractor without closed and latched cab doors increases the risk of serious injury or death in the event of an accident or rollover. Always make sure all cab doors are closed and latched while riding in this Tractor. Cab doors are NOT intended to be used as arm rests. Always keep hands and feet inside the Tractor at all times.

IMPROPER TIRE MAINTENANCE

WARNING

Operating this Tractor with improper tires or with improper or uneven tire pressure could cause loss of control or accident. Always use the size and type of tires specified for your Tractor. Always maintain proper tire pressure as described in the owner's manual and on safety labels.

OPERATING ON PAVEMENT

This Tractor's tires are designed for off-road use only, not for use on pavement. Operating this Tractor on paved surfaces (including sidewalks, paths, parking lots and driveways) may adversely affect the handling of the Tractor and may increase the risk of loss of control and accident or rollover. Avoid operating the Tractor on pavement. If it's unavoidable, travel slowly, travel short distances and avoid sudden turns or stops.

OPERATING ON PUBLIC ROADS

WARNING

Operating this Tractor on public streets, roads or highways could result in a collision with another Tractor. Never operate this Tractor on any public street, road or highway, including dirt and gravel roads (unless designated for off-highway use).

OPERATING AT EXCESSIVE SPEEDS

CAUTION

Operating this Tractor at excessive speeds increases the operator's risk of losing control. Always operate at a speed that's appropriate for the terrain, the visibility and operating conditions and your skills and experience.

JUMPS AND STUNTS

CAUTION

Exhibition driving increases the risk of an accident or rollover. **DO NOT** do power slides, "donuts", jumps or other driving stunts. Avoid exhibition driving.

TURNING IMPROPERLY

 CAUTION

Turning improperly could cause loss of traction, loss of control, accident or rollover. Always follow proper procedures for turning as described in this owner's manual.

Avoid sharp turns. Never turn while applying heavy throttle. Never make abrupt steering maneuvers. Practice turning at slow speeds before attempting to turn at faster speeds.

IMPROPER HILL CLIMBING

 CAUTION

Improper hill climbing could cause loss of control or rollover. Use extreme caution when operating on hills. Always follow proper procedures for hill climbing as described in this owner's manual.

DESCENDING HILLS IMPROPERLY

 CAUTION

Improperly descending a hill could cause loss of control or rollover. Always follow proper procedures for traveling down hills as described in this owner's manual.

CROSSING HILLSIDES

 CAUTION

Driving on a sidehill is not recommended. Improper procedure could cause loss of control or rollover. Avoid crossing the side of any hill unless absolutely necessary. If crossing a hillside is unavoidable, always follow proper procedures as described in this owner's manual.

SAFETY

STALLING WHILE CLIMBING A HILL



Stalling or rolling backwards while climbing a hill could cause a rollover.
Maintain a steady speed when climbing a hill.

If you lose all forward speed:

Apply the brakes gradually until the Tractor is fully stopped. Place the transmission in reverse and slowly allow the Tractor to roll straight downhill while applying light brake pressure to control speed.

If you begin rolling downhill:

Never apply engine power. Apply the brakes gradually until the Tractor is fully stopped. Place the transmission in reverse and slowly allow the Tractor to roll straight downhill while applying light brake pressure to control speed.

OPERATING IN UNFAMILIAR TERRAIN



Failure to use extra caution when operating on unfamiliar terrain could result in an accident or rollover.



Unfamiliar terrain may contain hidden rocks, bumps, or holes that could cause loss of control or rollover.

Travel slowly and use extra caution when operating on unfamiliar terrain. Always be alert to changing terrain conditions.

OPERATING IMPROPERLY IN REVERSE



Improperly operating in reverse could result in a collision with an obstacle or person. Always follow proper operating procedures as outlined in this manual.

Before shifting into reverse gear, always check for obstacles or people behind the Tractor. When it's safe to proceed, back slowly.

SKIDDING OR SLIDING

 CAUTION

Failure to use extra caution when operating on excessively rough, slippery or loose terrain could cause loss of traction, loss of control, accident or rollover. Do not operate on excessively slippery surfaces. Always slow down and use additional caution when operating on slippery surfaces.

 CAUTION

Skidding or sliding due to loss of traction can cause loss of control or rollover (if tires regain traction unexpectedly). Always follow proper procedures for operating on slippery surfaces as described in this owner's manual.

OPERATING OVER OBSTACLES

 CAUTION

Improperly operating over obstacles could cause loss of control or rollover. Before operating in a new area, check for obstacles. Avoid operating over large obstacles such as large rocks and fallen trees. Always follow the proper procedures outlined in this manual when operating over obstacles.

OPERATING THROUGH WATER

 CAUTION

Operating through deep or fast-flowing water can cause loss of traction, loss of control, rollover or accident. Never operate in fast-flowing water or in water that exceeds the floor level of the Tractor.

Always follow proper procedures for operating in water as described in this owner's manual.

Wet brakes will have reduced stopping ability. After leaving water, test the brakes. Apply them lightly several times while driving slowly. The friction will help dry out the pads.

OPERATING ON FROZEN BODIES OF WATER

WARNING

Serious injury or death can result if the Tractor and/or the operator fall through the ice. Never operate the Tractor on a frozen body of water unless you have first verified that the ice is sufficiently thick to support the weight and moving force of the Tractor, you and your cargo, together with any other Tractors in your party.

Always check with local authorities and residents to confirm ice conditions and thickness over your entire route. Tractor operators assume all risk associated with ice conditions on frozen bodies of water.

OPERATING A DAMAGED TRACTOR

CAUTION

Operating a damaged Tractor can result in an accident. After any rollover or other accident, have a qualified service dealer inspect the entire machine for possible damage, including (but not limited to) seat belts, rollover protection devices, brakes, throttle, and steering systems.

IMPROPER CARGO LOADING

Overloading the Tractor or carrying cargo improperly may cause changes in stability and handling, which could cause loss of control or an accident.

- Always follow the instructions in this owner's manual for carrying cargo.
- Never exceed the stated load capacity for this Tractor.
- Cargo should be properly distributed and securely attached.
- Reduce speed when carrying cargo or pulling a trailer. Allow a greater distance for braking.

POOR VISIBILITY

CAUTION

Operating this Tractor in darkness or inclement weather could result in a collision or accident, especially if operating on a road or street. This Tractor is not equipped with highway-approved lights. Operate this Tractor off-road only. Use caution and drive at reduced speeds in conditions of reduced visibility such as fog, rain and darkness. Clean headlights frequently and replace burned out headlamps promptly.

HOT EXHAUST SYSTEMS

 **WARNING**

Exhaust system components are very hot during and after use of the Tractor. Hot components can cause burns and fire. Do not touch hot exhaust system components. Always keep combustible materials away from the exhaust system.

Use caution when traveling through tall grass, especially dry grass and when traveling through muddy conditions. Always inspect the underside of the Tractor and areas near the exhaust system after driving through tall grass, weeds, brush, other tall ground cover, and muddy conditions. Promptly remove any grass, debris or foreign matter clinging to the Tractor and pay particular attention to the exhaust system area.

EXPOSURE TO EXHAUST

 **CAUTION**

Engine exhaust fumes are poisonous and can cause loss of consciousness or death in a short time. Never start the engine or let it run in an enclosed area. Operate this Tractor only outdoors or in well-ventilated areas.

REFUELING

Gasoline is highly flammable and explosive under certain conditions.

- Always exercise extreme caution whenever handling gasoline.
- Always turn off the engine when refueling.
- Always refuel outdoors or in a well ventilated area free of any source of flame or sparks.
- NEVER carry fuel or other flammable liquids on this Tractor. Failure to follow this instruction could lead to serious burn injuries or death.
- Do not smoke or allow open flames or sparks in or near the area where refueling is performed or where gasoline is stored.
- Do not overfill the tank. Do not fill the tank neck.
- If gasoline spills on your skin or clothing, immediately wash it off with soap and water and change clothing.

UNAUTHORIZED USE OF THE TRACTOR

Leaving the keys in the ignition can lead to unauthorized use of the Tractor by someone under the age of 16, without a drivers license, or without proper training. This could result in an accident or rollover. Always remove the ignition key when the Tractor is not in use.

SAFETY

EQUIPMENT MODIFICATIONS

Your EGIMOTORS Tractor is designed to provide safe operation when used as directed. Modifications to your Tractor may negatively impact Tractor stability. Failure of critical machine components may result from operation with any modifications, especially those that increase speed or power. This Tractor may become less stable at speeds higher than those for which it is designed. Loss of control may occur at higher speeds.

Do not install any non-EGIMOTORS-approved accessory or modify the Tractor for the purpose of increasing speed or power. Any modifications or installation of non-EGIMOTORS-approved accessories could create a substantial safety hazard and increase the risk of bodily injury.

The EGIMOTORS limited warranty on your EGIMOTORS Tractor will be terminated if any non-EGIMOTORS approved equipment and/or modifications have been added to the Tractor that increase speed or power.

The addition of certain accessories, including (but not limited to) mowers, blades, tires, sprayers, or large racks, may change the handling characteristics of the Tractor. Use only EGIMOTORS-approved accessories, and familiarize yourself with their function and effect on the Tractor.

The addition of certain accessories, including (but not limited to) overhead audio speakers, may change the forward clearance in the Tractor. EGIMOTORS recommends selecting a helmet that is compatible with the equipment on your Tractor and provides the greatest amount of forward clearance. Always wear a helmet that meets or exceeds the specifications in this owner's manual. Refer to the Safe Riding Gear section of this owner's manual for more information. Use only EGIMOTORS-approved accessories.

SAFETY LABELS AND LOCATIONS

Warning labels have been placed on the Tractor for your protection. Read and follow the instructions of the labels on the Tractor carefully. If any of the labels depicted in this manual differ from the labels on your Tractor, always read and follow the instructions of the labels on the *Tractor*.

If an informational or graphic label becomes illegible or comes off, contact your EGIMOTORS dealer to obtain a replacement. Replacement *safety* labels are provided by EGIMOTORS at no charge. The part number is printed on the label.

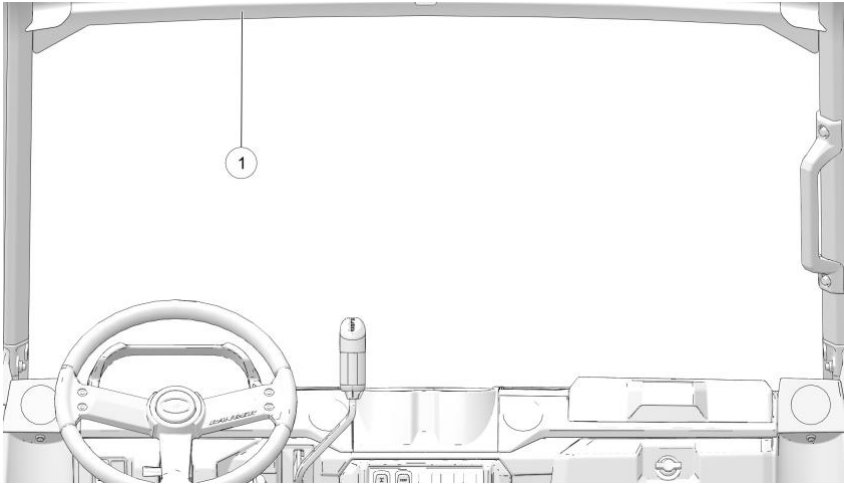

The safety labels 1 are located on the front ROPS, above the driver's head.

SAFETY

SEAT BELT / DRIVER WARNING

WARNING

Improper Tractor use can result in SEVERE INJURY or DEATH

Be Prepared

- Fasten seat belt.
- Wear an approved helmet and protective gear.
- ALWAYS use Tractor cab nets and/or doors.
- Each rider must be able to sit with back against seat, feet flat on the floor, and hands on steering wheel or handholds. Stay completely inside the Tractor.

Drive Responsibly

Avoid loss of control and rollovers:

- Avoid abrupt maneuvers, sideways sliding, skidding or fishtailing, and never do donuts.
- Slow down before entering a turn.
- Avoid hard acceleration when turning, even from a stop.
- Plan for hills, rough terrain, ruts and other changes in traction and terrain. Avoid paved surfaces.
- Avoid side-hilling (riding across slopes).

Be Sure Riders Pay Attention and Plan Ahead

If you think or feel the Tractor may tip or roll, reduce your risk of injury:

- Keep a firm grip on the steering wheel or handholds and brace yourself.
- Do not put any part of your body outside of the Tractor for any reason.

Rollovers have caused severe injuries and death, even on flat, open areas.

PROPER USE WARNING

CREW MODELS

WARNING

Improper Tractor Use Can Result in SEVERE INJURY or DEATH

Be sure riders pay attention and plan ahead.

If you think the Tractor may tip or roll, reduce your risk to injury:

- Keep a firm grip on the steering wheel or handholds and brace yourself.
- Do not put any part of your body outside of the Tractor for any reason.

Require Proper Use of Your Tractor.

Do your part to prevent injuries:

- Do not allow careless or reckless driving.
- Make sure operators are 18 or older with a valid driver's license.
- Do not let people drive or ride after using alcohol or drugs.
- Do not allow operation on public roads (unless designated for off-highway Tractor access) – collisions with cars and trucks can occur.

Do not exceed seating capacity: 6 occupants.

PAYLOAD WARNING/SHIFT CAUTION



CAUTION

To avoid transmission damage, shift only when Tractor is stationary and at idle. When Tractor is stopped, place shift in parked position.

SAFETY

FUEL TRANSPORT WARNING

The Fuel Transport Warning label is located in the cargo box.

WARNING

NEVER carry fuel or other flammable liquids on this Tractor

Failure to follow this instruction could lead to serious burn injuries or death.

Part number: 7186122 (English),
7186122-F (French Canadian)



CLUTCH COVER WARNING

WARNING

The Clutch Cover Warning q is located on the clutch cover.

- Improper service or maintenance of this PVT system can result in Tractor damage, SEVERE INJURY or DEATH.
- Always look for and remove debris inside and around clutch and vent system when replacing belt.
- Read owner's manual or see authorized EGIMOTORS dealer.

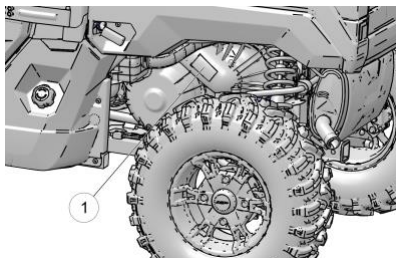

AIR BOX CAUTION

CAUTION

Use a EGIMOTORS approved air filter. The use of a non-EGIMOTORS approved air filter may cause engine damage. Before installing filter, ensure there is no dirt or debris in the clean side of the intake tube. The air filter must be properly seated before the lid is reinstalled. Please reference your owner's manual for additional information regarding air filter service.

LOAD/PASSENGER/TIRE PRESSURE WARNING

The Load/Passenger/Tire Pressure Warning is located in the cargo box.

WARNING

- Never carry passengers in cargo box.
- Passengers can be thrown off. This can cause serious injury or death.
- If total payload is greater than 500 lbs, the Tractor must be operated in LOW range.

WARNING

IMPROPER TIRE PRESSURE OR OVERLOADING CAN CAUSE LOSS OF CONTROL RESULTING IN SERIOUS INJURY OR DEATH.

- Reduce speed and allow greater distance for braking when carrying cargo.
 - Overloading or carrying tall, off-center, or unsecured loads will increase your risk of losing control. Loads should be centered and carried as low as possible in box.
 - For stability on rough or hilly terrain, reduce speed and cargo.
-

SAFETY

INTERNATIONAL SAFETY LABELS

GENERAL ALERT



⚠ WARNING

Read your owner's manual. Never allow anyone under 16 years of age to operate this Tractor. Never use alcohol or drugs before or while driving or riding. Do not allow operation on public roads (unless designated for off-highway Tractor access). Wear approved helmet, goggles, and protective clothing. Always wear seat belts. Always use the cab nets or doors. Never exceed seating capacity.

CLUTCH COVER ALERT

⚠ WARNING

Keep body parts away from belt.

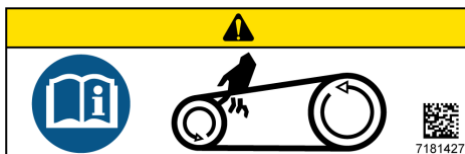

SHIFT ALERT

⚠ WARNING

To avoid transmission damage, shift only when Tractor is stationary and at idle. APPLY BRAKE TO START. When this Tractor is not in operation, or unattended, place shift in the park position.

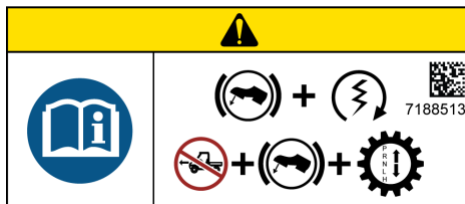

INTAKE ALERT

WARNING

Use a EGIMOTORS approved air filter. The use of a non-EGIMOTORS approved air filter may cause engine damage. Before installing filter ensure there is no dirt or debris in the clean side of the intake tube.

The air filter must be properly seated and the hinges fully inserted when the lid is reinstalled. Please reference your owner's manual for additional information regarding the air filter service.



Label Location: on the air box.

SAFETY

LOAD/PASSENGER/TIRE PRESSURE ALERT

Never carry passengers in cargo box. Passengers can be thrown off. This can cause serious injury or death. Read owner's manual. NEVER carry fuel or other flammable liquids on this Tractor. Failure to follow this instruction could lead to serious burn injuries or death.

FEATURES AND CONTROLS

COMPONENT LOCATIONS

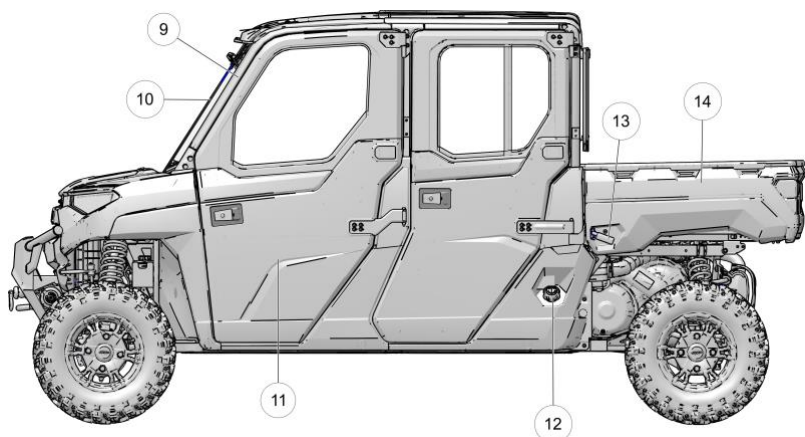
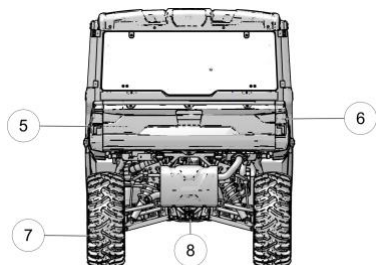
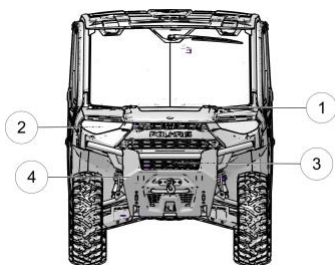

1 Console

2 Headlights

3 Radiator/AC Condenser

4 Bumper/Brush Guard

5 Tailgate

6 Taillights

7 Wheel/Tire

8 Receiver Hitch

9 ROPS Cab Frame

10 Windshield

11 Door

12 Fuel Cap

13 Cargo Box Release Lever

14 Cargo Box

CONSOLE

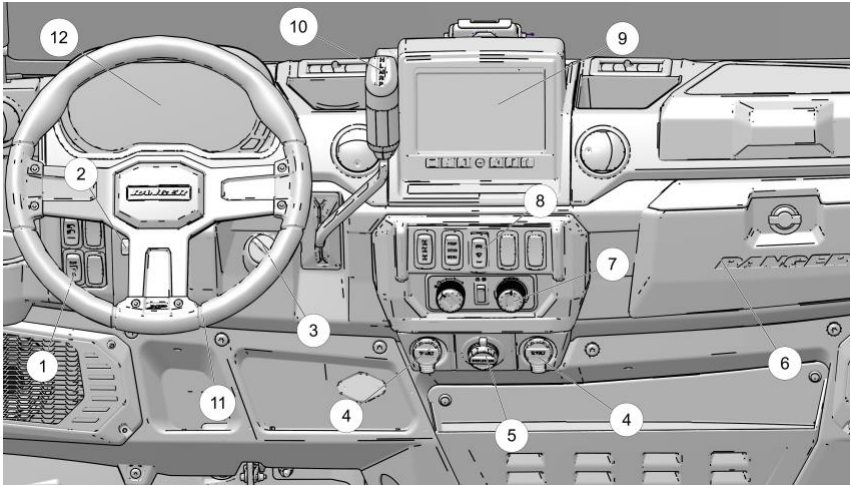

q Left-Side Switch Panel w
Steering Wheel Adjuster
e Ignition
r 12V Auxiliary Outlets
t Battery Trickle Charging Outlet
y Winch Remote (underneath hood, if
equipped)

u HVAC Control Panel (if equipped)
i Right-Side Switch Panel
o Ride Command Display (if
equipped)
a Gear Selector (Shifter)
s Steering Wheel
d Instrument Cluster

FEATURES AND CONTROLS

IGNITION SWITCH

The ignition switch is a four-position, key-operated switch. The key can be removed from the switch when it is in the OFF position.

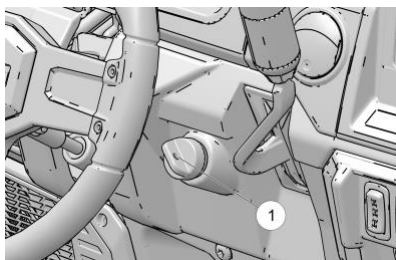

OFF	The engine is off. Electrical circuits are off.
ACCESSORY	The engine is off. Powers the gauge and terminal block. Check engine and steering warning indicators will appear on the gauge in this mode, but will turn off when the Tractor is started if no issues are present.
SYSTEM ON	Electrical circuits and position lights are on. Electrical equipment can be used.
START	Turn the key to the START position to engage the electric starter. The key returns to the ON position when released.

Ignition Switch Label (MD and HD models only)

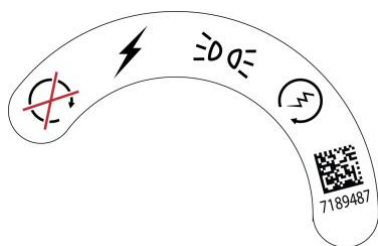

STEERING WHEEL

The steering wheel can be tilted upward or downward for rider preference. Lift and hold the steering wheel adjustment lever while moving the steering wheel upward or downward. Release the lever when the steering wheel is at the desired position. Always make sure the steering wheel position does not impede proper operation of the brake pedal, throttle pedal and all other controls.

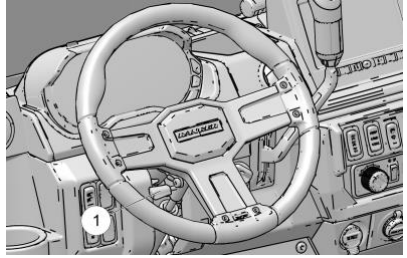

GEAR SELECTOR

To change gears, stop the Tractor, and with the engine idling, move the lever to the desired gear. Do not attempt to shift gears with engine speed above idle or while the Tractor is moving.

- H: High Gear
- L: Low Gear
- N: Neutral
- R: Reverse
- P: Park

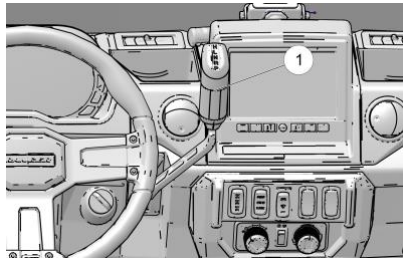

Low gear is the primary driving range for the RANGER. High gear is intended for use on hard-packed surfaces with light loads. Whenever the Tractor is left unattended, always place the transmission in PARK.

TIP

Maintaining shift linkage adjustment is important to assure proper transmission function. Your EGIMOTORS dealer or other qualified person can assist in resolving any shifting problems.

NOTICE

Do not attempt to shift the transmission while the Tractor is moving or damage to the transmission could result. Always shift when the Tractor is stationary and the engine is at idle.

FEATURES AND CONTROLS

SWITCHES

Not all switches are present on every model.

LIGHT SWITCH

The ignition switch key must be in the ON/RUN position to operate the headlights. Press the top of the rocker switch toward the dash to place the headlights on high beam. Move the rocker switch to the center position to place the headlights on low beam. Press the bottom of the rocker switch to turn off the headlights.

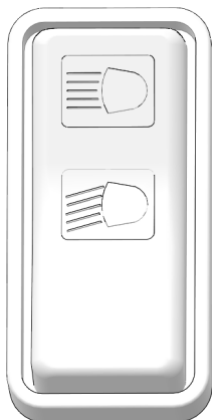

AWD SWITCH

The AWD switch has three positions: All Wheel Drive (AWD), Differential Lock/Two Wheel Drive (2WD) and Off (1WD / Turf Mode).

Press the top of the switch to engage All Wheel Drive (AWD).

Move the switch to the center position to lock the differential and operate in two wheel drive (2WD).

Press the bottom of the switch to unlock the differential and allow the rear drive wheels to operate independently (1WD / Turf Mode). This mode of operation is well suited to turf driving or when active traction is not needed.



3-MODE THROTTLE CONTROL SWITCH

The 3-Mode Throttle Control Switch has three positions:

- Performance (PERF)
- Standard (STND)
- Work (WORK)

Always use low gear for any of the following conditions regardless of the selected throttle control setting:

- Operating in rough terrain or over obstacles.
- Loading the Tractor onto a trailer.
- Towing heavy loads.
- Driving frequently at low RPM or at ground speeds below 7 MPH (11 km/h).



ACTIVE DESCENT CONTROL (ADC) SWITCH (IF EQUIPPED)

The ADC system allows engine braking to all four wheels when the Tractor descends a hill or incline. Press the top of the switch to engage ADC. Press the bottom of the switch to turn off ADC. Always operate in low gear and engage ADC before ascending or descending a hill.

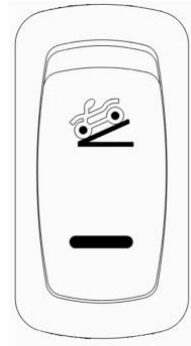

FEATURES AND CONTROLS

HVAC CONTROL PANEL (IF EQUIPPED)

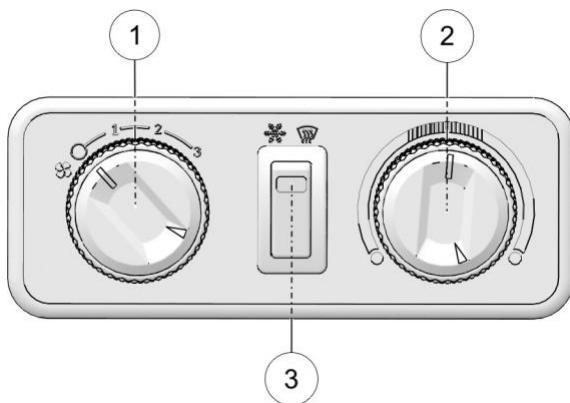

To operate the cab heater, rotate the fan control to the desired fan speed setting. The far left setting turns the fan off.

Adjust the temperature by rotating the temperature control to the desired heat setting. Rotate the control clockwise to increase heat or counter-clockwise to decrease heat.

Press the top of the A/C switch to enable the air conditioning system for cooling or defrost purposes.

WINDSHIELD WIPER/WASHER SWITCH (IF EQUIPPED)

The windshield wiper/washer switch is located on the Tractor dashboard. The windshield washer fluid reservoir is located under the hood.

Select the desired function by pressing the top or bottom of the switch. The windshield wiper/washer switch has three positions:

- WASHER ON - top of switch fully pressed
- WIPER ON - middle position
- OFF - bottom of switch fully pressed



WINCH CONTROLS (IF EQUIPPED)

NOTE

Tractors equipped with factory-installed winches have an automatic stop function to prevent overtightening when the winch is fully wound.

WINCH SWITCH

Press the top of the rocker switch to spool line out from the winch. Press the bottom of the rocker switch to spool line in to the winch. Move the rocker switch to the center position to stop spooling.



REMOTE WINCH SWITCH (IF EQUIPPED)

The remote winch switch is located under the hood. To power-on or power-off the switch, press and hold the power button for 3 seconds. Press and hold the button labeled "OUT" to spool line out from the winch. Press and hold the button labeled "IN" to spool line in to the winch. The switch will automatically power-off after 30 seconds of inactivity.



FEATURES AND CONTROLS

AUXILIARY OUTLET

The Tractor is equipped with 12-volt accessory outlets on the dash. Use the outlets to power an auxiliary light or other optional accessories or lights. For service, the dash outlet connection is under the dash.



BATTERY TRICKLE-CHARGING OUTLET

The Tractor is equipped with a dedicated outlet for trickle-charging the battery during periods of extended inactivity.

If you do not drive the Tractor for more than TWO WEEKS, EGIMOTORS recommends using a BatteryMINDER® 2012 AGM - 2 AMP charger, which can be ordered through your dealer.

EGIMOTORS provides a charging accessory with your Tractor that allows easy connection to the battery through the Battery Trickle-Charging Outlet, located on the dash. While charging, place the charger outside of the Tractor and protect it from moisture.



FOOT PEDALS

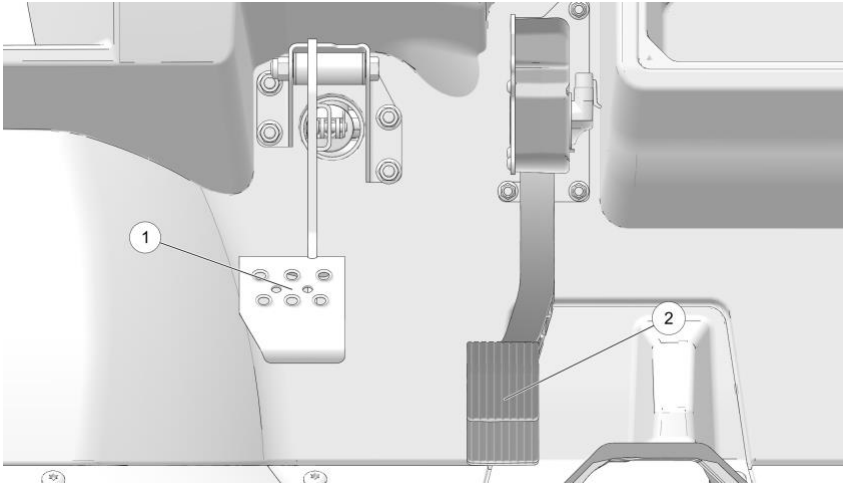

BRAKE PEDAL

Depress the brake pedal **q** to slow or stop the Tractor. Apply the brakes while starting the engine.

When the brake pedal is depressed, the brake light comes on. Check the brake light before each ride.

1. Turn the ignition switch to the ON position.
2. Apply the brakes. The brake light should come on after about 10 mm (0.4 in.) of pedal travel.

FEATURES AND CONTROLS

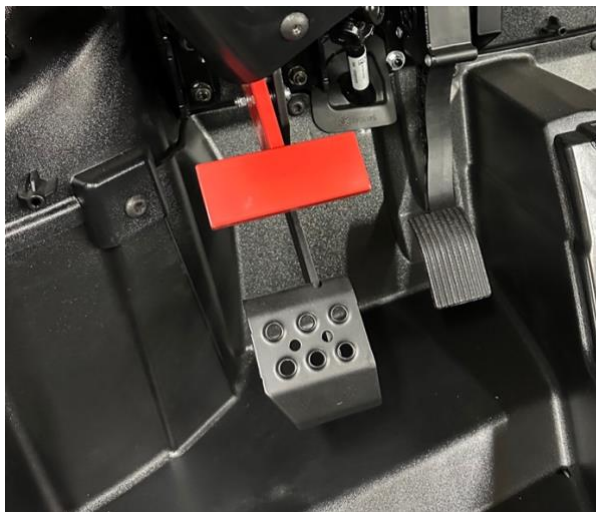

SECONDARY PEDAL

Your Tractor is equipped with a secondary Foot pedal in case of need and fail of the primary

THROTTLE PEDAL

Push the throttle pedal w down to increase engine speed. Spring pressure returns the pedal to the rest position when released. Always check that the throttle pedal returns normally before starting the engine.

TIP

If the throttle pedal and brake pedal are applied simultaneously, engine power may be limited.

PARK BRAKE LEVER (IF EQUIPPED)

Always apply the service brakes before engaging or releasing the park brake. To help prevent the Tractor from rolling, set the park brake when parking the Tractor. When the park brake is set and the park brake indicator is illuminated, engine speed is limited. If the accelerator is applied, this limiting feature prevents operation, which protects the park brake pads from excessive wear.

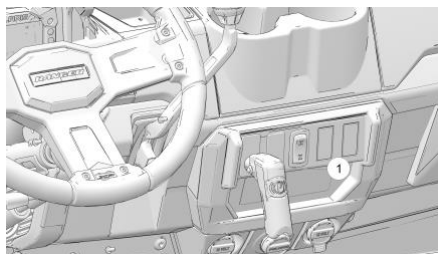

NOTICE

This feature will not operate properly if the park brake connector or switch (under the hood) malfunctions or becomes disconnected, or if the switch has moved. Check for disconnection, then see your dealer or other qualified service person promptly if this feature fails to operate properly.

1. To set the park brake, apply the brakes. Pull the park brake lever *q* towards yourself as far as possible.
2. To release the park brake, apply the brakes. Turn the park brake lever counterclockwise and push it in as far as possible.

NOTICE

When the parking brake is engaged, the word "BRAKE" will appear in Display Area 2 of the Instrument Cluster.

SEAT

SEAT BELTS

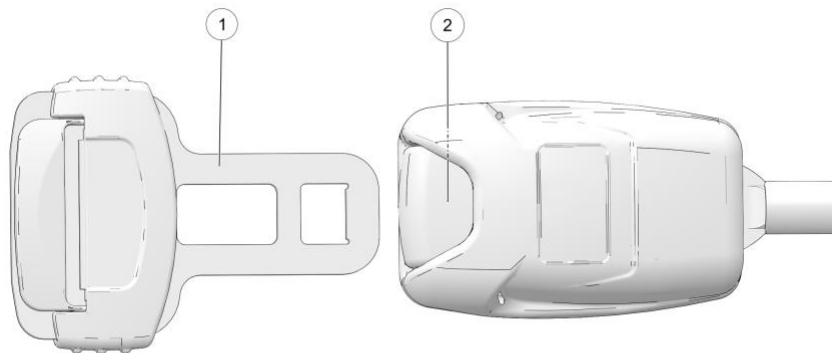

This Tractor is equipped with three-point lap and diagonal seat belts for the operator and any passengers. Always make sure the seat belts are secured for all riders before operating. The driver's seat belt is equipped with a seat belt interlock. Tractor speed will be limited to 15 MPH (24 km/h) if the seat belt is not secured.

WARNING

Falling from a moving Tractor could result in serious injury or death. Always fasten your seat belt securely before operating or riding in the Tractor.

To wear the seat belt properly, follow this procedure:

1. For 3-point belts, pull the seat belt latch *q* downward and across your chest toward the buckle at the inner edge of the seat. The belt should fit snugly across your hips and diagonally across your chest. Make sure the belt is not twisted.
 2. Push the latch plate *q* into the buckle *w* until it clicks.
 3. Release the strap, it will self tighten.
 4. To release the seat belt, press the square red button in the buckle's center.
-

SEAT BELT INSPECTION



Failure to perform regular inspection can reduce the effectiveness of the seat belt during a crash and could result in serious injury or death.

Inspect all seat belts for proper operation before each use of the Tractor.

1. Push the latch plate into the buckle until it clicks. The latch plate must slide smoothly into the buckle. A click indicates that it's securely latched.
2. Push the red release latch in the middle of the buckle to make sure it releases freely.
3. Pull each seat belt completely out and inspect the full length for any damage, including cuts, wear, fraying or stiffness. If any damage is found, or if the seat belt does not operate properly, have the seat belt system checked and/or replaced by an authorized dealer.
4. To clean dirt or debris from the seat belts, sponge the straps with mild soap and water. Do not use bleach, dye or household detergents. Rinse the entire length of the belt webbing. Use a garden hose to flush out the retractor and latch housings regularly.

SEAT AND STORAGE COMPARTMENTS

The electrical compartment is located under the center rear-most seat. Never use this area for storage. Storage compartments are located under all other seats. Remove the storage bin under the center rear-most seat to access the battery and electrical compartment.

Always make sure all seats are properly installed before operating.

DRIVER'S SEAT

To access the storage area under the driver's seat, reach behind the driver's seat and pull up on the latch. Roll the bottom of the seat forward toward steering wheel.

PASSENGER'S SEAT

To access the storage area under the passenger seat, lift up on the front of the passenger seat and raise it to the upright position.

FEATURES AND CONTROLS

ELECTRONIC POWER STEERING

Electronic power steering (EPS) engages when the ignition key is turned to the ON position. EPS remains engaged whether the Tractor is moving or idle. To conserve battery power, the EPS will shut down 5 minutes after the engine is stopped if the key remains in the ON position. The EPS warning indicator will illuminate to indicate the EPS has shut down. Turn the key off and on to reset the unit. If the light remains on after starting the engine, the EPS system is inoperative. See your EGIMOTORS dealer, or other qualified person, as soon as possible for repair. Continued operation could result in permanent damage to the EPS unit and increased steering effort.

FUEL CAP

The fuel tank filler cap q is located on the left-hand side of the Tractor near the driver's seat. To close, tighten the fuel cap until it clicks twice. When refueling, always use unleaded gasoline with a minimum pump octane number of 87 R+M/2 octane. Do not use fuel with ethanol content greater than 10 percent, such as E-85 fuel. Compatible fuels: E5 and E10

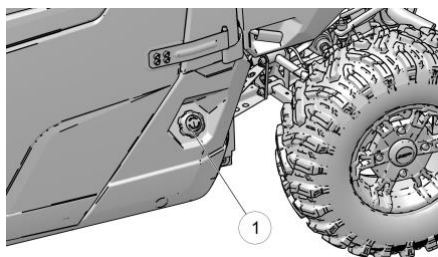

Always ensure that the fuel tank filler cap is fully tightened and secure before operating or transporting the Tractor.

ROLLOVER PROTECTIVE STRUCTURE (ROPS)

The Rollover Protective Structure (ROPS) on this Tractor meets OSHA® 1928.53 rollover performance requirements. Always have your authorized dealer thoroughly inspect the ROPS if it ever becomes damaged in any way.

No device can assure occupant protection in the event of a rollover. Always follow all safe operating practices outlined in this manual to avoid Tractor rollover.

WARNING

Tractor rollover could cause severe injury or death. Always avoid operating in a manner that could result in Tractor rollover.

HOOD LATCHES

To remove the hood, rotate the hood latches **q** 1/4-turn and lift the hood away from the Tractor.

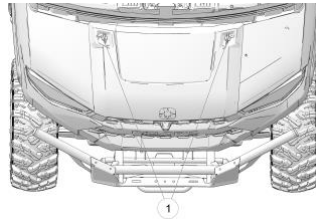

REAR WINDOW PANEL (IF EQUIPPED)

WINDOW REMOVAL

1. Rotate the upper window latches **q** counter-clockwise to release the locks.
2. Tilt the upper edge of the window slightly outward and free the lower window brackets **w** from the frame, then carefully lift the window up and away from the Tractor.
3. Secure the upper window latches.
4. To prevent damage to the window during storage, store it in an upright position in a secure area. Place the lower frame of the window on wood or another semi-soft surface.

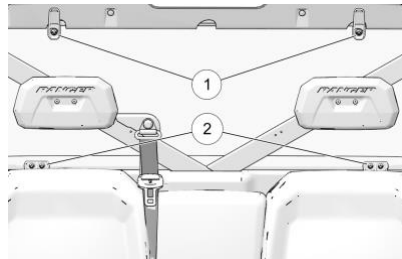

WINDOW INSTALLATION

1. Rotate the upper window latches counter-clockwise to release the locks.
2. From the rear of the cab, place the lower edge of the window into the window opening, hooking the lower window brackets over the frame of the Tractor inside the cab.
3. Align the upper edge of the window to the window opening.
4. Secure the upper window latches.

TRAILER HITCH BRACKET

This Tractor is equipped with a receiver hitch bracket for a trailer hitch. Trailer towing equipment is not supplied with this Tractor.

To avoid injury and property damage, always heed the warnings and towing capacities.

FEATURES AND CONTROLS

INSTRUMENT CLUSTER

NOTICE

High water pressure may damage components. Wash the Tractor by hand or with a garden hose using mild soap. Certain products, including insect repellents and chemicals, will damage the speedometer lens and other plastic surfaces. Do not use alcohol to clean the instrument cluster. Do not allow insect sprays to contact the lens. Immediately clean off any gasoline that splashes on the instrument cluster.



q Speedometer

w Tachometer

e Indicator Lamps

r Mode Button

t Toggle Buttons

y Rider Information Center

SPEEDOMETER

The speedometer displays Tractor speed in either miles per hour (MPH) or kilometers per hour (km/h).

TACHOMETER

The tachometer displays engine speed in revolutions per minute (RPM).

MODE AND TOGGLE BUTTONS



Press and hold the MODE button **r** to enter or exit the settings menu. Press and release the MODE button to cycle through Area 1 modes and to select an item.

Press and release either toggle button **t** to cycle through the options menu or Area 2 modes. Press and hold either toggle button to reset an item. See page 67.





TIP

With the ignition key off, pressing the MODE button or either toggle button will power up the Rider Information Center for 10 seconds to allow viewing of the odometer and the clock.



INDICATOR LAMPS

INDICATOR	ICON	FUNCTION
Tractor Speed	MPH	When standard mode is selected, speed displays in miles per hour.
	km/h	When metric mode is selected, speed displays in kilometers per hour.
Check Engine		This indicator appears if a fault occurs. Do not operate the Tractor if this warning appears. Serious engine damage could result. Your authorized EGIMOTORS dealer can assist.
Check Battery		This warning usually indicates that the Tractor is operating at an RPM too low to keep the battery charged. It may also occur when the engine is at idle and high electrical load (lights, cooling fan, accessories) is applied. Drive at a higher RPM or recharge the battery to clear the warning.
EPS Warning (if equipped)		This indicator illuminates briefly when the key is turned to the ON position. If the light remains on, the EPS system is inoperative. See your EGIMOTORS dealer, or other qualified person, as soon as possible for repair. Continued operation could result in permanent damage to the EPS unit and increased steering effort.

FEATURES AND CONTROLS

INDICATOR	ICON	FUNCTION
Engine Hot		This lamp illuminates to indicate an overheated engine. If the indicator flashes, the overheating condition remains, and the system will automatically reduce engine power.
Neutral		This lamp illuminates when the transmission is in neutral and the ignition key is in the ON position.
Helmet/Seat Belt		This lamp is a reminder to the operator to ensure all riders are wearing helmets and seat belts before operating. The driver's seat belt is equipped with a seat belt interlock. Tractor speed will be limited to 15 MPH (24 km/h) if the seat belt is not secured.
High Beam		This lamp illuminates when the headlamp switch is set to high beam.
Park Brake (if equipped)		Lamp illuminates when the Park Brake is applied (if equipped).

FEATURES AND CONTROLS

INDICATOR	ICON	FUNCTION
Low Fuel		This lamp illuminates when fuel level in the fuel tank is low.
Speed Key (optional accessory)		Information about the speed key is provided in the accessory kit.

RIDER INFORMATION CENTER

q	Gear Indicator	This indicator displays gear shifter position. H = High Gear L = Low Gear N = Neutral R = Reverse Gear P = Park – = Gear Signal Error (or shifter between gears)
w	AWD Indicator	This indicator shows whether 2X4, AWD, or TURF Mode is active.
e	Service Indicator	A flashing wrench symbol alerts the operator that the preset service interval has been reached. Your EGIMOTORS dealer, or other qualified person, can provide scheduled maintenance. See page 70 for resetting instructions.
r	Fuel Gauge	The segments of the fuel gauge show the level of fuel in the fuel tank. When the last segment clears, a low fuel warning is activated. The outline of the fuel display will flash. Refuel immediately.
t	Speed Limitation (if equipped)	This Tractor may be equipped with a maximum speed limitation function. This would be displayed on the screen as “LIM” followed by the speed. “LIM 30” for example.

FEATURES AND CONTROLS

The rider information center is located in the instrument cluster. All segments will light up for one second at start-up.

If the instrument cluster fails to illuminate, a battery over-voltage may have occurred and the instrument cluster may have shut off to protect the electronic speedometer. If this occurs, your EGIMOTORS dealer, or other qualified person, can provide proper diagnosis.

The information center is set to display standard units of measurement and a 12-hour clock at the factory. To change to metric and/or a 24-hour clock hold the mode button and cycle to the clock menu. Use the directional arrows to change the clock settings.

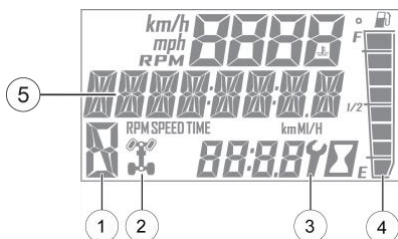

MODE INFORMATION DISPLAYS

The rider information center contains three areas that display mode information.

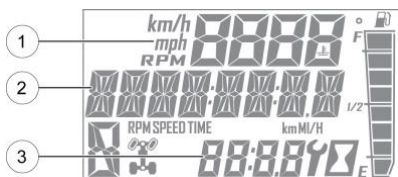

q Area 1 Modes	Description
Engine Temperature	Temperature of engine coolant
Tractor Speed	Speed of Tractor
Tachometer	Engine speed (RPM)
w Area 2 Modes	Description
Odometer	The odometer records and displays the distance traveled by the Tractor.
Trip Meters (T1/T2)	A trip meter records the distance traveled by the Tractor if reset before each trip. To reset, see page 69.
Engine Hours	Total hours of engine operation since manufacture

FEATURES AND CONTROLS

Service Hours	A flashing wrench symbol indicates that the preset service interval has been reached. To reset, see page 70.
Trip Time	Time length of Tractor operation since mode was last reset
e Area 3 Modes	Description
Clock	The clock displays time in a 12-hour or 24-hour format. To reset, see page 68.

FEATURES AND CONTROLS

ACCESSING MENUS AND OPTIONS

GAUGE SETTINGS MENU

Press and release the MODE button to cycle through the Area 1 modes until the desired default mode displays. See the Mode Information Displays section for details.

Press and hold the MODE button to enter the settings menu.

The OPTIONS screen will display for a few seconds.

1. Press and release either toggle button to cycle to the desired option.
2. Press MODE to select the option.
3. Press either toggle button to cycle to the desired setting.
4. Press MODE to save and exit to the settings menu.
5. Press and hold the MODE button to exit the settings menu.

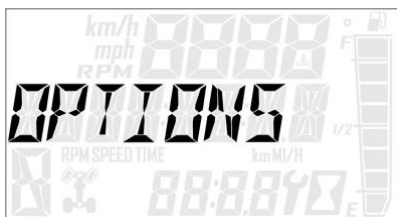

BACKLIGHT COLOR

The information center backlight can be set to either blue or red.

1. Press and hold the MODE button to enter the settings menu.
2. Press either toggle button to cycle to the "BL COLOR" option. Press MODE to select.
3. Press either toggle button to cycle to the desired setting.
4. Press MODE to save and exit to the settings menu,



BACKLIGHT BRIGHTNESS

The information center backlight can be set to either blue or red.

1. Press and hold the MODE button to enter the settings menu.
2. Press either toggle button to cycle to the "BL LEVEL" option. Press MODE to select.
3. Press "UP" button to increase brightness. Press "DOWN" button to decrease brightness.
4. Press MODE to select and exit to the settings menu.



CLOCK

The clock must be reset any time the battery has been disconnected or discharged.

1. Press and hold the MODE button to enter the settings menu.
2. Press either toggle button to cycle to the "CLOCK" option. Press MODE to select.
3. Press either toggle button to cycle to the desired setting (12H or 24H). Press MODE to select.
4. Press either toggle button to change each segment of the clock. Press MODE to accept a change and advance to the next segment.



FEATURES AND CONTROLS

DISPLAY UNITS (STANDARD/METRIC)



1. Press and hold the MODE button to enter the settings menu.
2. Press either toggle button to cycle to the desired "UNITS" option (distance, temperature or volume). Press MODE to select.
3. Press either toggle button to cycle to the desired setting.
4. Press MODE to save and exit to the settings menu.

TRIP METER

Use a trip meter to track the distance traveled during a specific trip or period of time. Reset the meter to zero before traveling.

1. Press either toggle button to cycle to the desired trip meter option (T1 or T2).
2. Press and hold either toggle button until the meter resets to zero.



TRIP TIME

Use a trip time meter to track the travel time during a specific trip. Reset the meter to zero before traveling.

1. Press either toggle button to cycle to the trip time option (TT).
2. Press and hold either toggle button until the meter resets to zero.



PROGRAMMABLE SERVICE INTERVAL

The service interval counter is programmed to 25 hours at the factory. As hours of engine operation increase, the counter decreases. The wrench icon will flash for about 10 seconds when the counter reaches zero (0), and each time the key is turned on thereafter, until the counter is reset.

When this feature is enabled, it provides a convenient reminder to perform routine maintenance. Refer to the Periodic Maintenance Chart for recommended service intervals.

Use the following procedure to reset or change the service interval.

1. Press and hold the MODE button to enter the settings menu.
2. Press either toggle button to cycle to the "Service Hours" option. Press MODE to select.
3. Press MODE to reset the existing value and exit, or press either toggle button to change the value. Press MODE to save and exit to the settings menu.



ENGINE ERROR CODES

The error screen displays only when the CHECK ENGINE indicator is on or when it goes on and off during one ignition cycle. Error codes are not stored. When the key is turned OFF, the code and message is lost, but will reappear if the fault reoccurs after restarting the engine.

If the CHECK ENGINE lamp or the EPS lamp illuminates, retrieve the active error codes from the display.

q Failure Mode Indicator (FMI)

w Suspect Parameter Number (SPN)

e Code Count

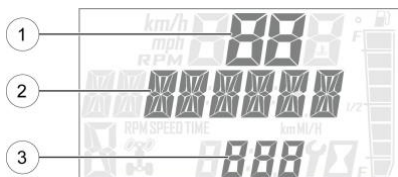

1. Press and hold the MODE button to enter the settings menu.
2. Press either toggle button to cycle to the “DIAGCODE” option. Press MODE to select.
3. More than one diagnostic code may be present. Press the toggle UP button to see if more codes are present. Press MODE to select a code.

NOTICE

If the displayed code is an engine fault code, the CHECK ENGINE lamp will blink. If the displayed code is an EPS fault code, the EPS lamp will blink.

4. Record the three (3) numbers displayed.
 5. Press MODE to exit to the settings menu.
-

RIDE COMMAND DISPLAY (IF EQUIPPED)

RIDE COMMAND DISPLAY (IF EQUIPPED)

BEFORE YOU RIDE

Before riding with your new display, do the following:

- Read this and the Ride Command User's Guide in their entirety.
- Familiarize yourself with the features and operations of the Display while the Tractor is stationary.
- Download the EGIMOTORS RIDE COMMAND App from the Apple® App Store® or Google Play® store and create your personalized account.
- Check your display to ensure you have the appropriate maps and trails visible for your area. To change or update maps/trails see page 81.
- Check <https://www.EGIMOTORS.com/en-us/owners-manuals/> for the latest updates to the owner's manual.

NOTICE

Trails change often, and the trail data file is only considered valid for 90 days after the release date. Please keep your trail data up to date. Download the latest trails at <http://ridecommand.EGIMOTORS.com>.

NOTICE

Using the display for an extended period of time while the Tractor's engine is off can drain the battery.

DEVICE OPERATING REQUIREMENTS

Phone functionality is dependent on the capabilities of your cell phone.

NOTICE

Some cell phones or operating systems will not work as shown in this manual.

RIDE COMMAND DISPLAY (IF EQUIPPED)

OVERVIEW

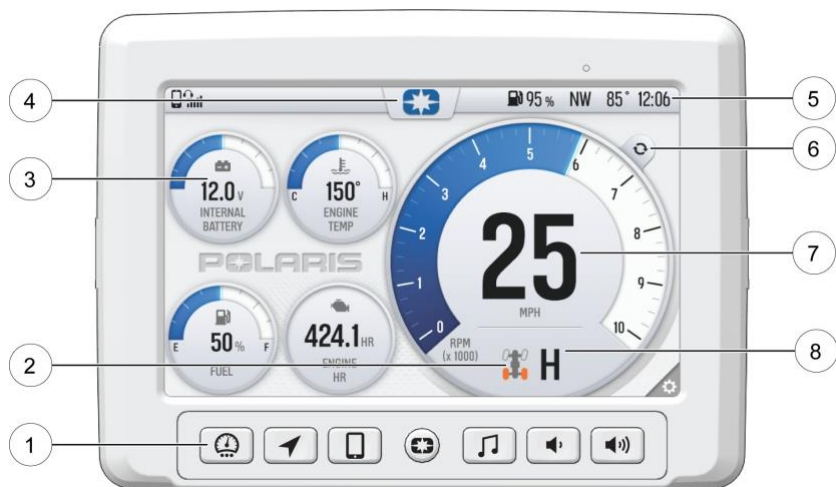

q Ride Command Buttons

w Driveline Mode

e Widgets

r Settings



t Icon Bar

y Gauge View Mode





u Speedometer/Tachometer

i Gear Status

RIDE COMMAND BUTTONS



BUTTON	DESCRIPTION	FUNCTION
	Menu Button	Press the Menu button to access the settings. To reboot the display, press and hold for 5 seconds.
	Gauge Screen Button	Press the Gauge Screen button to select from available screens.

RIDE COMMAND DISPLAY (IF EQUIPPED)

BUTTON	DESCRIPTION	FUNCTION
	Map Button	Press the Map button to access the map, manage your rides and waypoints, and to see your friends on the map with Group Ride.
	Phone Button	Press the Phone button to access your Bluetooth® connected phone, including recent calls, contacts, dialer, and messages.
	Audio Button	Press the Audio button to access the Radio, Weather, USB, and connected Bluetooth® music interface
	Volume Decrease Button	Press the Volume Decrease button to decrease the volume. Press and hold to mute volume.
	Volume Increase Button	Press the Volume Increase button to increase the volume.

RIDE COMMAND DISPLAY (IF EQUIPPED)

DRIVELINE MODE

INDICATOR	DESCRIPTION	FUNCTION
	2WD	When the switch is on 2X4, the Tractor is in two-wheel drive at all times.
	AWD	When in All-Wheel Drive, the demand drive unit will automatically engage any time the rear wheels lose traction. When the rear wheels regain traction, the demand drive unit will automatically disengage. There is no limit to the length of time the Tractor may remain in 4X4. The Tractor automatically engages 4X4 when operating in reverse if the switch is set to 4X4 position.
	Turf Mode (if equipped)	When operating in TURF mode, the inside rear wheel will rotate independently from the outside wheel during turns. Operate in TURF mode only as needed to protect smooth, level surfaces from tire damage. DO NOT operate in TURF mode when climbing or descending hills, when sidehilling, or when operating on uneven, loose, or slippery terrain such as sand, gravel, ice, snow, obstacles, and water crossings. Always operate in AWD on these types of terrain.

RIDE COMMAND DISPLAY (IF EQUIPPED)

GAUGE SCREENS

Press the Gauge Screen button to toggle between gauge screens. The display comes loaded with two different gauge screens. Additional gauge screens can be added or deleted.

Each gauge screen is customizable and can be set up in the following configurations:

- Four round widgets
- Two round widgets and a list of three data values
- A list of five data values

To customize your gauge screens, press the gear icon located in the lower right corner of the display.



SETTINGS

From the setting menu you can view Tractor information, manage Bluetooth® devices, update display software, and more.

To access the Setting menu, press the Menu button q.

You can also navigate to the settings menu by pressing the EGIMOTORS logo at the top of the display screen w. This will open the Control Panel. From the Control Panel, select the settings tab, then press the **All Settings** button located in the lower right corner of the display screen.



RIDE COMMAND DISPLAY (IF EQUIPPED)

GAUGE VIEW MODE

Press **q** to toggle between the two available gauge view modes, **Analog** and **Digital**.

While in the digital gauge view mode, press **w** to invert the MPH and RPM units.



DISPLAY MODE

From the Control tab **e**, select the display mode from the available options **y**. The display mode can be set to Day, Night, or AUTO mode.

Day Mode



Night Mode



RIDE COMMAND DISPLAY (IF EQUIPPED)

ICON BAR



ICON	DESCRIPTION	FUNCTION
q	Headset	Displays icon if headset is connected
w	Signal Strength	Displays current cell signal strength
e	Wireless Internet Signal Strength (if equipped)	Displays current wireless internet signal strength (if equipped)
r	Fuel Level	Displays current fuel capacity percentage
t	Tractor Direction	Displays Tractor direction
y	Ambient Temperature	Displays ambient temperature
u	Clock	Displays current time

RIDE COMMAND DISPLAY (IF EQUIPPED)

UPDATE SOFTWARE

NOTICE

Before updating the Display, always export your existing rides and waypoints to a USB drive to avoid losing them.

To update the software, do the following:

ON YOUR PERSONAL COMPUTER

1. Go to ridecommand.EGIMOTORS.com/update.
2. Log into your account, or create a new account.
3. Using the Tractor Identification Number (VIN), add your new EGIMOTORS Tractor to your Garage.
4. Locate and download the latest software to a USB flash drive (8+ GB).

ON YOUR TRACTOR

1. Connect the USB flash drive to the USB cable and power up your Tractor.
2. On the RIDE COMMAND display, select the Settings menu on your display by pressing the EGIMOTORS icon at the top of the screen.
3. Select General Settings, then Update Software.
4. Select the file you wish to load (use date listed in the file name to determine most recent file).
5. Select Yes to restart display (restart required).

ERROR MESSAGES

If an error occurs while updating your software, perform one or all of the following actions to resolve the issue:

1. Remove and reconnect the USB flash drive securely.
 2. Make sure the display files are not inside a folder on the flash drive.
 3. Make sure only display files are on the flash drive. Remove any other files if necessary.
 4. Try using a different USB flash drive.
-

UPDATE MAPS

To update the maps on your display, do the following:

1. Go to *ridecommand.EGIMOTORS.com/update* and download the map update to a USB flash drive.
2. Insert USB flash drive into the USB port on your Tractor.
3. Press the Update maps in the General Settings.
4. Select the file you want to install by pressing the corresponding down arrow icon.
5. This will update the display's map which will automatically restart the display once the update is complete. Do not remove the USB flash drive until the display has fully restarted.

USB HARDWARE

SOFTWARE UPDATES

For software update, EGIMOTORS recommends using a SanDisk® or similar USB flash drive with a minimum of 4GB in available memory, formatted using the FAT32 or exFAT® file systems. For best results remove all files from the flash drive before starting the update process.

MAP UPDATES

For Map updates, a 32GB USB drive is required (USB 3.0 drive is highly recommended) USB drive must be formatted to exFAT® before copying the map file onto it.

TRAIL UPDATES

For Trail updates, a 4GB drive formatted to FAT32 can be used.

OPERATION

IMPORTANT INFORMATION

⚠ WARNING

Failure to operate the Tractor properly can result in a collision, loss of control, accident or rollover, which may result in serious injury or death. Read and understand all safety warnings outlined in the safety section of this owner's manual.

TRACTOR BREAK-IN PERIOD

The break-in period for your new Tractor is the first 25 hours of operation, or the time it takes to use the first 2 full tanks of gasoline. No single action on your part is as important as a proper break-in period. Careful treatment of a new engine will result in more efficient performance and longer life for the engine. Perform the following procedures carefully.

NOTICE

Excessive heat build-up during the first 3 hours of operation will damage close-fitted engine parts and drive components. Do not operate at full throttle or high speeds during the first 3 hours of use.

ENGINE AND DRIVETRAIN BREAK-IN

1. Fill the fuel tank with gasoline. Always exercise extreme caution whenever handling gasoline.
 2. Check the oil level. Add the recommended oil as needed to maintain the oil level in the safe operating range.
 3. Complete the New Operator Driving Procedures.
 4. Avoid aggressive use of the brakes.
 5. Vary throttle positions. Do not operate at sustained idle.
 6. Pull only light loads.
 7. Perform regular checks on fluid levels, controls and areas outlined on the daily pre-ride inspection checklist.
 8. During the break-in period, change both the oil and the filter at 25 hours or one month.
 9. Check fluid levels of transmission and all gearcases after the first 25 hours of operation and every 100 hours thereafter.
-

OPERATION

BRAKE SYSTEM BREAK-IN

Apply only moderate braking force for the first 50 stops. Aggressive or overly forceful braking when the brake system is new could damage brake pads and rotors.

PVT BREAK-IN (CLUTCHES/BELT)

Always break in the clutches and drive belt of new Tractors, as well as after a belt replacement.

A proper break-in of the clutches and drive belt will ensure a longer life and better performance. Break in the clutches and belt by operating at slower speeds during the break-in period as recommended. Pull only light loads. Avoid aggressive acceleration and high speed operation during the break-in period.

If a belt fails, always clean any debris from the PVT intake and outlet duct and from the clutch and engine compartments when replacing the belt.

PRE-RIDE INSPECTION



Failure to inspect and verify that the Tractor is in safe operating condition before operating increases the risk of an accident. Always inspect the Tractor before each use to make sure it's in safe operating condition.

ITEM	REMARKS	PAGE
Brake system/pedal travel	Ensure proper operation	
Brake fluid	Ensure proper level	
Front suspension	Inspect, lubricate if necessary	page 108
Rear suspension	Inspect, lubricate if necessary	page 108
Steering	Ensure free operation	-
Tires	Inspect condition and pressure	page 134
Wheels/fasteners	Inspect, ensure fastener tightness	page 134
Frame nuts, bolts, fasteners	Inspect, ensure tightness	-
Drive Belt	Inspect, ensure installed correctly	-
Fuel and oil	Ensure proper levels	page 108
Coolant level	Ensure proper level	page 117
Coolant hoses	Inspect for leaks	-

OPERATION

ITEM	REMARKS	PAGE
Throttle	Ensure proper operation	page 55
Indicator lights/switches	Ensure proper operation	page 62 page 50
Intake pre-filters	Inspect, clean	-
Headlamps	Check operation, apply EGIMOTORS dielectric grease when lamp is replaced	page 137
Brake light/tail lamps	Check operation	-
Seat Latch	Push down on the seat back to ensure the latch is secure	-
Seat Belt	Check length of belt for damage, check latches for proper operation	page 57
Cab Doors (if equipped)	Check doors and latches for wear or damage.	-
Grass and leaves	Remove grass, leaves, foreign matter, and other flammable material or debris, especially near the exhaust system.	-

OPERATION

SAFE OPERATION PRACTICES

1. Visit the Recreational Off-Highway Tractor Association® web site and take the free on-line training course. Complete the recommended safety training before operating this Tractor. Visit www.rohva.org or call 866-267-2751.
 2. Do not allow anyone under 16 years of age or without a valid driver's license to operate this Tractor.
 3. Engine exhaust fumes are poisonous and can cause loss of consciousness or death in a short time. Never start the engine or let it run in an enclosed area.
 4. Never operate with accessories not approved by EGIMOTORS for use on this Tractor.
 5. Operate this Tractor off-road only. Never operate this Tractor on any public street, road or highway, including dirt and gravel roads (unless designated for off-highway use).
 6. Use caution and drive at reduced speeds in conditions of reduced visibility such as fog, rain and darkness. Clean headlights frequently and replace burned out headlamps promptly.
 7. Always operate at a speed that's appropriate for the terrain, the visibility and operating conditions and your skills and experience. Never operate at excessive speeds. Never attempt wheelies, jumps, or other stunts. Keep both hands on the steering wheel during operation.
 8. Never consume alcohol or drugs before or while operating this Tractor.
 9. Always use the size and type of tires specified for your Tractor. Always maintain proper tire pressure.
 10. Never operate a damaged Tractor. After any rollover or accident, have a qualified service dealer inspect the entire machine for possible damage.
 11. Never operate the Tractor on a frozen body of water unless you have first verified that the ice is sufficiently thick to support the weight and moving force of the Tractor, you and your cargo, together with any other Tractors in your party.
 12. Do not touch hot exhaust system components. Always keep combustible materials away from the exhaust system.
 13. Always remove the ignition key when the Tractor is not in use to prevent unauthorized use.
-

KNOW YOUR RIDING AREA/TREAD LIGHTLYSM

Familiarize yourself with all laws and regulations concerning the operation of this Tractor in your area. Respect the environment in which you ride your Tractor. Find out where the designated riding areas are by contacting your EGIMOTORS dealer, a local riding club, or local officials.

Help keep our trails open for recreational Tractor use. As an off-road enthusiast, you represent the sport and can set a good example (or a poor example) for others to follow. Tread LightlySM. Operate with respect for the terrain, avoid littering, and always stay on the designated trails.

TRAIL ETIQUETTE

Always practice good etiquette when riding. Allow a safe distance between your Tractor and other Tractors operating in the same area. Communicate to oncoming operators by signaling the number of Tractors in your group. When stopping, move your Tractor to the edge of the trail as far as possible to allow others to pass safely.

STARTING THE ENGINE

1. Position the Tractor on a level surface outdoors or in a well ventilated area.
2. Sit in the driver's seat and fasten the seat belt. Secure the cab doors (if equipped).
3. Place the transmission in PARK.
4. Apply the brakes. Do not press the throttle pedal while starting the engine.
5. Turn the ignition key past the ON/RUN position to START. Engage the starter for a maximum of five seconds. Release the key when the engine starts.
6. If the engine does not start within five seconds, return the ignition switch to the OFF position and wait five seconds. Repeat steps 5 and 6 until the engine starts.
7. Vary the engine RPM slightly with the throttle to aid in warm up until the engine idles smoothly.

NOTICE
Operating the Tractor immediately after starting could cause engine damage. Allow the engine to warm up for several minutes before operating the Tractor.

OPERATION

USING LOW GEAR

Low gear is the primary driving range for the RANGER. High gear is intended for use on hard-packed surfaces with light loads. Whenever the Tractor is left unattended, always place the transmission in PARK.

Always shift into low gear for any of the following conditions.

- Operating in rough terrain or over obstacles
- Loading the Tractor onto a trailer
- Towing heavy loads
- Driving slowly - under 10 MPH (16 km/h)
- Climbing hills

COLD WEATHER OPERATION

If the Tractor is used year-round, check the oil level frequently. A rising oil level could indicate the accumulation of contaminants such as water or excess fuel in the bottom of the crankcase. Water in the bottom of the crankcase can lead to engine damage and must be drained. Water accumulation increases as outside temperature decreases.

FUEL RECOMMENDATIONS

Most EGIMOTORS Off-Road Tractors require unleaded gasoline with a minimum pump octane number of 87. Do not use fuel with an ethanol content greater than 10 percent. Octane in excess of 87 will not damage the engine but typically will not result in performance gains.

Be aware that fuel is mixed differently depending on the season. Summer fuel has a low Reid Vapor Pressure (RVP), which makes it less likely to evaporate in warm weather riding. This prevents vapor lock issues. Winter fuel has a higher RVP, which increases evaporation to ease starting in cold weather conditions. In winter, it's important to drain your tank and fill it with fresh fuel from a high volume gas station. This ensures your fuel is a winter blend. After filling the tank, run the engine for 10 to 15 minutes. This will fill the fuel system with the fresh winter-blended fuel.

STOPPING THE ENGINE

1. Release the throttle pedal completely and brake to a complete stop.
 2. Place the transmission in PARK.
 3. Turn the key to the OFF position.
 4. Slowly release the brake pedal and make sure the transmission is in PARK before exiting the Tractor.
-

 **WARNING**

A rolling Tractor can cause serious injury. Always place the transmission in PARK before stopping the engine.

BRAKING

1. Release the throttle pedal completely.

NOTICE

When the throttle pedal is released completely and engine speed slows to near idle, the Tractor has no engine braking.

2. Press on the brake pedal evenly and firmly. Practice starting and stopping (using the brakes) until you're familiar with the controls.

EMERGENCY BRAKING

A secondary brake pedal is available in case of emergency
(breakage of the main one)

PARKING THE TRACTOR

1. Stop the Tractor on a level surface. When parking inside a garage or other structure, be sure that the structure is well ventilated and that the Tractor is not close to any source of flame or sparks, including any appliance with pilot lights.
 2. Place the transmission in PARK.
 3. Turn the engine off.
 4. Engage the parking brake (if equipped).
 5. Slowly release the brake pedal and make sure the transmission is in PARK before exiting the Tractor.
 6. Remove the ignition key to prevent unauthorized use.
-

DRIVING PROCEDURES

NEW OPERATOR DRIVING PROCEDURES

1. Read and understand the owner's manual and all warning and instruction labels before operating this Tractor.
2. Perform the pre-ride inspection.
3. Do not tow or carry cargo during this period.
4. Select an open area that allows room to familiarize yourself with Tractor operation and handling. The driver must wear helmet, eye protection, gloves, long-sleeve shirt, long pants, over-the-ankle boots and seat belt at all times.
5. Sit in the driver's seat and fasten the seat belt.
6. Always make sure all cab doors are closed and latched when riding in this Tractor.
7. Place the transmission in PARK.
8. Start the engine.
9. Apply the brakes and shift into low gear.
10. Check your surroundings and determine your path of travel.
11. Keeping both hands on the steering wheel, slowly release the brakes and depress the throttle with your right foot to begin driving.
12. Drive slowly at first. On level surfaces, practice starting, stopping, turning, maneuvering, using the throttle and brakes and driving in reverse. Learn how the Tractor handles when making both left and right turns at a slow speed.

 **WARNING**

Operating in TURF mode (if equipped) when on sloped, uneven, or loose terrain could cause loss of control and result in serious injury or death. One rear wheel may slip and lose traction or may lift up and grab when it touches the ground again.

13. Increase speed only after mastering all maneuvers at a slow speed.
14. After you become skilled at making turns and begin to operate at faster speeds, follow these precautions:
 - Avoid sharp turns.
 - Never turn while applying heavy throttle.
 - Never make abrupt steering maneuvers.
 - Operate at speeds appropriate for your skills, the conditions and the terrain.
 - DO NOT do power slides, “donuts”, jumps or other driving stunts.

DRIVING WITH A PASSENGER

- Perform the pre-ride inspection.
 - Make sure all passengers are at least 12 years of age and tall enough to comfortably and safely sit in a passenger seat with the seat belt secured, put both feet on the floor and grasp the hand hold.
 - Make sure all passengers are wearing helmets, eye protection, gloves, long-sleeve shirt, long pants and over-the-ankle boots.
 - Make sure all cab nets or doors (if equipped) are properly secured.
 - Do not carry more than the recommended number of passengers for your Tractor.
 - Allow a passenger to ride only in a passenger seat.
 - Slow down. Always travel at a speed appropriate for your skills, your passengers’ skills, and operating conditions. Avoid unexpected or aggressive maneuvers that could cause discomfort or injury to a passenger.
 - Tractor handling may change with a passenger and/or cargo on board. Allow more time and distance for braking.
 - Always follow all operating guidelines as outlined on safety labels and in this manual.
-

OPERATION

DRIVING ON SLIPPERY SURFACES

WARNING

Skidding or sliding can cause loss of control or rollover (if tires regain traction unexpectedly). When operating on slippery surfaces such as ice or loose gravel, reduce speed and use extra caution to reduce the chance of skidding or sliding out of control. Do not operate on excessively slippery surfaces.

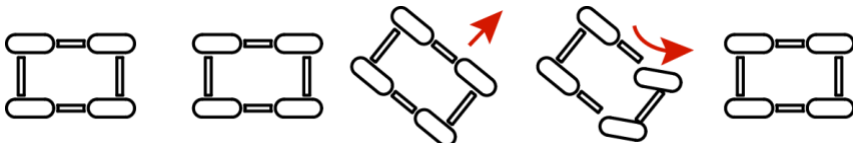

When driving on slippery surfaces such as wet trails, loose gravel, or ice, be alert for the possibility of skidding and sliding. Follow these precautions when encountering slippery conditions:

- Do not operate on excessively rough, slippery or loose terrain.
- Slow down before entering slippery areas.
- Maintain a high level of alertness, reading the trail and avoiding quick, sharp turns, which can cause skids.
- Engage all-wheel drive before wheels begin to lose traction.

NOTICE

Severe damage to the drive train may occur if the AWD is engaged while the wheels are spinning. Always allow the wheels to stop spinning before engaging AWD.

- Correct a skid by turning the steering wheel in the direction of the skid. *Never apply the brakes during a skid.*

DRIVING OVER OBSTACLES

Follow these precautions when operating over obstacles:

- Always check for obstacles before operating in a new area.
- Look ahead and learn to read the terrain. Be constantly alert for hazards such as logs, rocks and low hanging branches.
- Travel slowly and use extra caution when operating on unfamiliar terrain. Not all obstacles are immediately visible.
- Move the gear selector to Low Gear, if needed.
- Avoid operating over large obstacles such as large rocks and fallen trees. If unavoidable, use extreme caution and operate slowly.
- Always have all passengers dismount and move away from the Tractor before operating over an obstacle that could cause a rollover.

DRIVING UPHILL

Whenever traveling uphill, follow these precautions:

- Avoid excessively steep hills.
 - ADC Models: Always operate in low gear and engage ADC 4X4 before ascending or descending a hill.
 - Always travel straight uphill.
 - Keep both feet on the floor.
 - Always check the terrain carefully before ascending any hill. Never climb hills with excessively slippery or loose surfaces.
 - Proceed at a steady rate of speed and throttle opening. Never open the throttle suddenly.
 - Never go over the crest of a hill at high speed. An obstacle, a sharp drop, or another Tractor or person could be on the other side of the hill.
-

OPERATION

DRIVING DOWNHILL

When driving downhill, follow these precautions:

- Avoid excessively steep hills.
- ADC Models: Always operate in low gear and engage ADC 4X4 before ascending or descending a hill.
- Drive straight downhill. Avoid descending a hill at an angle, which would cause the Tractor to lean sharply to one side. Travel straight downhill when possible.
- Slow down.
- Apply the brakes slightly to aid in slowing.

ACTIVE DESCENT CONTROL (ADC) SYSTEM (IF EQUIPPED)

The ADC system allows engine braking to all four wheels when the Tractor descends a hill or incline. The ADC system is automatically engaged when the transmission is in gear (high, low or reverse). The ADC system automatically disengages when the transmission is shifted to neutral or park.

See the Active Descent Control (ADC) Switch section for details on how to operate the ADC switch.

DRIVING ON A SIDEHILL (SIDEHILLING)

Driving on a sidehill is not recommended. Improper procedure could cause loss of control or rollover. Avoid crossing the side of any hill unless absolutely necessary.

If crossing a sidehill is unavoidable, follow these precautions:

- Slow down.
 - Exercise extreme caution.
 - Avoid crossing the side of a steep hill.
 - ADC Models: Always operate in low gear and engage ADC 4X4 before ascending or descending a hill.
-

DRIVING THROUGH WATER

Your Tractor can operate through water up to a maximum recommended depth equal to the floorboards.

If equipped with high mounted intakes, your Tractor can operate through standing water up to a height equal to the seat base level.

NOTICE

If your Tractor becomes immersed or is operated in water that exceeds the floor level, service is required before starting the engine. Your dealer can provide this service. If it's impossible to bring the Tractor in before starting the engine, perform the service outlined in the Spark Arrester section, and take the Tractor in for service at the first opportunity.

Follow these procedures when operating through water:

1. Determine water depths and current before entering water.
2. Choose a crossing where both banks have gradual inclines.
3. Proceed slowly, avoiding rocks and obstacles.
4. Avoid operating through deep or fast-flowing water.

WARNING

The large tires on your Tractor may cause the Tractor to float in deep or fast-flowing water, which could result in loss of control and lead to serious injury or death. Never cross deep or fast-flowing water with your Tractor

5. After leaving water, always dry the brakes by applying light pressure to the pedal repeatedly until braking action is normal.

NOTICE

After running your Tractor in water, it's critical that you perform the services outlined in the Periodic Maintenance Chart. Give special attention to engine oil, transmission oil, front and rear gearcases (if equipped), and all grease fittings.

OPERATION

DRIVING IN REVERSE

Follow these precautions when operating in reverse:

- Always check for obstacles or people behind the Tractor. Always inspect left and right fields of vision before backing.
- Always avoid backing downhill.
- Back slowly.
- Apply the brakes lightly for stopping.
- Avoid turning at sharp angles.
- Never open the throttle suddenly.

PARKING THE TRACTOR

To park the Tractor, do the following:

1. Apply the brakes. Stop the Tractor on a level surface.
2. When parking inside a garage or other structure, be sure that the structure is well ventilated and that the Tractor is not close to any source of flame or sparks, including any appliance with pilot lights.
3. Place the transmission in PARK.
4. Turn the engine off.
5. Engage the park brake (if equipped).
6. Slowly release the brake pedal and make sure the transmission is in PARK before exiting the Tractor.
7. Remove the ignition switch key to prevent unauthorized use.

PARKING ON AN INCLINE

Avoid parking on an incline if possible. If it's unavoidable, follow these precautions:

1. Apply the brakes.
 2. Place the transmission in PARK.
 3. Engage the parking brake (if equipped).
 4. Turn the engine off.
 5. Slowly release the brake pedal and make sure the transmission is in PARK before exiting the Tractor.
 6. Block the rear wheels on the downhill side.
-

HAULING CARGO

 **WARNING**

Overloading the Tractor or carrying or towing cargo improperly can alter Tractor handling and may cause loss of control or brake instability. Always follow these precautions when hauling cargo:

Never exceed the stated load capacity for this Tractor.

REDUCE SPEED AND ALLOW GREATER DISTANCES FOR BRAKING WHEN HAULING CARGO.

NEVER EXCEED THE MAXIMUM WEIGHT CAPACITY of the Tractor. When determining the weight you are adding to the Tractor, include the weight of the operator, passenger, accessories, loads in the rack or box and the load on the trailer tongue. The combined weight of these items must not exceed the maximum weight capacity.

Always load the cargo box with the load as far forward and as low as possible. When operating over rough or hilly terrain, reduce speed and cargo to maintain stable driving conditions.

Always operate the Tractor with extreme care when hauling or towing loads. Slow down and drive in the lowest gear available.

SECURE ALL LOADS BEFORE OPERATING. Unsecured loads can create unstable operating conditions, which could result in loss of control of the Tractor.

OPERATE ONLY WITH STABLE AND SAFELY ARRANGED LOADS. When handling off-centered loads that cannot be centered, securely fasten the load and operate with extra caution.

Always attach the tow load to the hitch point designated for your Tractor. **HEAVY LOADS CAN CAUSE BRAKING AND CONTROL PROBLEMS.** Use extreme caution when applying brakes with a loaded Tractor. Avoid terrain or situations that may require backing downhill.

USE EXTREME CAUTION when operating with loads that extend over the rack sides. Stability and maneuverability may be adversely affected, causing Tractor rollover.

DO NOT TRAVEL FASTER THAN THE RECOMMENDED SPEEDS. Tractor should never exceed 10 MPH (16 km/h) while towing a load on a level grass surface. Tractor speed should never exceed 5 MPH (8 km/h) when towing loads in rough terrain, while cornering, or while ascending or descending a hill.

If the Tractor is capable, never exceed 43 MPH (70 km/h) if total payload exceeds 335 lbs. (152 kg).

Carrying a passenger in the cargo box could result in a fall from the Tractor or contact with moving components. Never allow a passenger to ride in the cargo box.

Your Tractor has been designed to carry or tow specific capacities. Reduce speed and allow a greater distance for braking when carrying cargo.

OPERATION

Loads should be centered on the Tractor and carried as low as possible in the box. For stability on rough or hilly terrain, reduce both speed and cargo. Exercise caution if the cargo load extends over the side of the box.

Always read and understand the load distribution warnings listed on warning labels and in this manual. Never exceed the maximum capacities specified for your Tractor.

BELT LIFE

To extend belt life, use low gear when hauling or towing heavy cargo.

TOWING LOADS

WARNING

Towing improperly can alter Tractor handling and may cause loss of control or brake instability.

Always follow these precautions when towing:

1. Never load more than 250 lbs. (113.4 kg) tongue weight on the towing bracket.
2. When towing a disabled Tractor, place the disabled Tractor's transmission in neutral. Do not operate the Tractor faster than 10 MPH (16 km/h) when towing.
3. Towing a trailer increases braking distance. Do not operate the Tractor faster than 10 MPH (16 km/h) when towing.
4. Do not tow more than the recommended weight for the Tractor.
5. Attach a trailer to the trailer hitch bracket only. Do not attach a trailer to any other location, which could result in loss of control of the Tractor.
6. The total load (operator, accessories, cargo and weight on hitch) must not exceed the maximum weight capacity of the Tractor.

MODEL	TOTAL TOWED LOAD WEIGHT (LEVEL GROUND)	TOTAL TOWED LOAD WEIGHT (15° GRADE)	TOTAL HITCH VERTICAL WEIGHT	MAXIMUM TOWING SPEED
All RANGER XP 1000 models	2500 lbs. (1134 kg)	850 lbs. (386 kg)	250 lbs (113.4 kg)	10 MPH (16 km/h)

DUMPING THE CARGO BOX

To dump the cargo box, do the following:

1. Select a level site to dump the cargo box. Do not attempt to dump or unload the Tractor while parked on an incline.
2. Apply the brakes.
3. Shift the gear selector to the Park position.
4. Turn the key to the off position.
5. Dismount Tractor.
6. Ensure that the cargo is positioned evenly or toward the front of the cargo box.
7. Open the tailgate.
8. Stand clear and pull up on the cargo box release lever.
9. Lift the front of the cargo box to dump the cargo.
10. Lower the cargo box and push down securely to latch.
11. Close the tailgate.



WARNING

Operating the Tractor while the cargo box is raised could result in severe injury. The box could close unexpectedly and cause injury to the driver or passenger. The rear tires will also catch the rear of a raised box, damaging the Tractor and creating hazardous driving conditions. Never operate this Tractor with the cargo box in the raised position.

OPERATION

ALL WHEEL DRIVE/REAR DIFFERENTIAL SYSTEM

If your model is equipped with a lockable differential, you can choose to operate with an open differential or a closed differential.

ENGAGING AWD

NOTICE

Switching to AWD while the rear wheels are spinning may cause severe drive shaft and clutch damage. Always switch to AWD while the rear wheels have traction or are at rest.

- q All-Wheel Drive (AWD)
- w Differential Lock
- e Differential Unlock (Turf Mode)

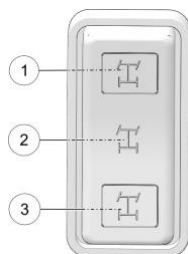

Press the top of the switch to engage All Wheel Drive (AWD). The 4X4 indicator illuminates in the rider information center to indicate that the Tractor is in AWD. When the AWD switch is on, the front gearcase will automatically engage any time the rear wheels lose traction. When the rear wheels regain traction, the front gearcase will automatically disengage. There is no limit to the length of time the Tractor may remain in AWD. Initially, the Tractor's electronic system will not enable the AWD until the engine RPM is below 3100. Once enabled, the AWD remains enabled until the AWD switch is turned off. If the switch is turned off while the front gearcase is moving, it will not disengage until the rear wheels regain traction.

Engage the AWD before getting into conditions where front wheel drive may be needed. If the rear wheels are spinning, release the throttle before switching to AWD.

DISENGAGING AWD

Move the AWD switch to the center or bottom position to disengage AWD. If the switch is turned off while the front hubs are driving, they will not release until the rear wheels regain traction.

In some situations, the front gearcase may remain locked after turning the AWD switch off. If this occurs, you may notice increased steering effort and some Tractor speed restriction. Perform the following procedure to unlock the front gearcase.

To disengage AWD, do the following:

1. Stop the Tractor.
2. Operate in reverse for at least 10 ft (3 m).
3. Stop completely.
4. Shift into low gear and drive forward.
5. If the front gearcase remains locked after following these instructions, see your dealer or other qualified service person for service.

LOCKING THE DIFFERENTIAL

Move the rocker switch to the center position to lock the differential and operate in two wheel drive (2WD). Locking the differential in slippery or low traction conditions helps improve traction. When the rear differential is locked, both rear wheels rotate at the same speed.

OPERATION

UNLOCKING THE DIFFERENTIAL (TURF MODE)

When operating in TURF mode, the inside rear wheel will rotate independently from the outside wheel during turns. Operate in TURF mode only as needed to protect smooth, level surfaces from tire damage. DO NOT operate in TURF mode when climbing or descending hills, when sidehilling, or when operating on uneven, loose, or slippery terrain such as sand, gravel, ice, snow, obstacles, and water crossings. Always operate in AWD on these types of terrain.

WARNING

Operating in TURF mode (if equipped) when on sloped, uneven, or loose terrain could cause loss of control and result in serious injury or death. One rear wheel may slip and lose traction or may lift up and grab when it touches the ground again.

Press the bottom of the switch to unlock the differential and allow the rear drive wheels to operate independently (1WD). When the rear differential is unlocked, the rear wheels can rotate at different speeds. Unlock the differential to make maneuvering easier and minimize damage to turf.

NOTICE

Damage to the differential can occur if it is engaged while the Tractor is traveling at high speeds or while the rear wheels are spinning. Slow the Tractor to nearly stopped before engaging the differential.

WARNING

Never operate in TURF mode (if equipped) while operating on a hill or other irregular terrain. Always move the AWD switch to AWD before ascending or descending a hill.

EMISSION CONTROL SYSTEMS

NOISE EMISSION CONTROL SYSTEM

Do not modify the engine, intake or exhaust components, as doing so may affect compliance with U.S.A. EPA noise control requirements (40 CFR 205) and local noise level requirements.

OPERATION ON PUBLIC LANDS IN THE U.S.A.

Your Tractor has a spark arrestor that was tested and qualified to be in accordance with the USFS standard 5100-1a. Federal law requires that this spark arrestor be installed and functional when the Tractor is operated on public lands.

Operation of off-road Tractors on public lands in the U.S.A. is regulated by 43 CFR 420. Violations are subject to monetary penalties. Federal regulations can be viewed online at <https://ecfr.federalregister.gov/current/title-43/subtitle-B/chapter-1/part-420>.

CRANKCASE EMISSION CONTROL SYSTEM

This engine is equipped with a closed crankcase system. Blow-by gases are forced back to the combustion chamber by the intake system. All exhaust gases exit through the exhaust system.

EXHAUST EMISSION CONTROL SYSTEM

Exhaust emissions are controlled by engine design. An electronic fuel injection (EFI) system controls fuel delivery. The engine and EFI components are set at the factory for optimal performance and are not adjustable.

The emissions label is located on the inside of the lower left frame tube (below driver's foot area).

ELECTROMAGNETIC INTERFERENCE

This spark ignition system complies with Canadian ICES-002.

This Tractor complies with the EMC requirements of UN ECE Regulation 10.

Non-ionizing Radiation: This Tractor emits some electromagnetic energy. People with active or non-active implantable medical devices (such as heart monitoring or controlling devices) should review the limitations of their device and the applicable electromagnetic standards and directives that apply to this Tractor.

MAINTENANCE

EGIMOTORS MAINTENANCE SCHEDULE

The intervals shown in this table are based on Tractors operated under normal conditions.

Each interval is given in hours and miles (kilometers). Items should be serviced at whichever interval comes first.

Continue to reference the following maintenance schedules at the given intervals as hours and miles (kilometers) increase on the Tractor.

Tractors subjected to severe use must be serviced at 50% of the stated interval. Examples of Severe Use: Frequent immersion in mud, water, or sand, constant high RPM use, prolonged low-speed heavy load operation, extended idle, and short trip cold weather operation.

INITIAL BREAK-IN SERVICE FIRST 25 HOURS / 250 MILES (400 KM)

Brake System	Initial fluid level inspection; inspect for fluid leaks; add lubricant if needed. Inspect brake pad wear.
Engine Oil and Filter	Change the engine oil and filter.
Front Gearcase Fluid	Change fluid.
Transmission Fluid	Initial fluid level inspection; inspect for fluid leaks; add lubricant if needed.
The break-in period consists of the first 25 hours of operation. Careful treatment of a new engine and drive components will result in more efficient performance and longer life for these components. The items outlined in this service interval only need to be performed at the first 25 hours of operation. They do not need to be performed every 25 hours.	

Tractors subjected to severe use must be serviced at 50% of the stated interval. Examples of Severe Use: Frequent immersion in mud, water, or sand, constant high RPM use, prolonged low-speed heavy load operation, extended idle, and short trip cold weather operation.

EVERY 50 HOURS / 500 MILES (800 KM)

Brake Pad Wear	Inspect; replace as needed.
General Lubrication	Locate all applicable fittings and grease.
Engine Breather	Inspect; clean as needed.

MAINTENANCE

Tractors subjected to severe use must be serviced at 50% of the stated interval. Examples of Severe Use: Frequent immersion in mud, water, or sand, constant high RPM use, prolonged low-speed heavy load operation, extended idle, and short trip cold weather operation.

EVERY 100 HOURS / 1000 MILES (1600 KM) OR YEARLY

Air Filter	Replace air filter. Ensure proper installation of filter and airbox cover. Inspect ducts and screens; clean as necessary.
Battery	Check terminals; terminals should be tight and free of corrosion. Clean, test, and replace as necessary.
Brake Pad Wear	Inspect; replace as needed.
Cooling System	Fluid level inspection; inspect for fluid leaks; add coolant if needed. Inspect coolant strength seasonally; pressure test system yearly.
Drive Belt	Inspect; replace as needed.
Engine Breather	Inspect; clean as needed.
Engine Oil and Filter	Change the engine oil and filter.
Exhaust Silencer / Pipe	Inspect for leaks or damage.
Front Gearcase Fluid	Change fluid.
Front / Rear Suspension	Lubricate (if applicable).
Fuel System*	Cycle key to pressurize fuel pump; check for leaks at fuel system connections, check for leaks at fill cap.
General Lubrication	Locate all applicable fittings and grease.
Parking Brake (if applicable)*	Inspect and adjust as needed.
Spark Arrestor	Clean out.
Spark Plugs	Inspect; replace as needed.
Suspension Components*	Inspect tie rods, wheel bearings, suspension bushings, and ball joints for loose or worn components; replace as needed. Inspect shock absorbers for leaks or damage.

MAINTENANCE

EVERY 100 HOURS / 1000 MILES (1600 KM) OR YEARLY

Transmission Fluid	Change fluid.
Wiring	Inspect for wear, routing, and retention.
* It is recommended to have an authorized EGIMOTORS dealer perform these services.	

Tractors subjected to severe use must be serviced at 50% of the stated interval. Examples of Severe Use: Frequent immersion in mud, water, or sand, constant high RPM use, prolonged low-speed heavy load operation, extended idle, and short trip cold weather operation.

ADDITIONAL MAINTENANCE INTERVALS

Every 200 hours / 2000 miles (3200 km)	Shock Absorbers*	Change shock oil or rebuild (if applicable). Inspect seals and replace as needed.
Every 500 hours / 5000 miles (8000 km)	Valve Clearance*	Inspect; adjust as needed.
Every 600 hours / 6000 miles (9700 km)	Clutches*	Inspect bushings, rollers, wearable parts; clean; replace worn parts. Inspect drive belt.
Every 24 months / 2 years	Brake Fluid	Change fluid.
Every 60 months / 5 years	Coolant	Change fluid.
* It is recommended to have an authorized EGIMOTORS dealer perform these services.		

MAINTENANCE

LUBRICATION RECOMMENDATIONS

Check and lubricate all components at the intervals outlined in the Periodic Maintenance Chart, or more often under severe use, such as wet or dusty conditions. Items not listed in the chart should be lubricated at the general lubrication interval.

ITEM	LUBE	METHOD
Engine Oil	PS-4 5W-50 4-Cycle Oil	Add to proper level on dipstick. See page 108.
Brake Fluid	DOT 4 Brake Fluid	Maintain level between fill lines. See .
Transmission Oil (Main Gearcase)	AGL Gearcase Lubricant & Transmission Fluid	See page 113.
Demand Drive Fluid (Front Gearcase)	Demand Drive Fluid	See page 115.
Prop Shaft	U-Joint Grease	Locate fittings and grease.

ENGINE OIL

Always check and change the oil at the intervals outlined in the Periodic Maintenance Chart. Always use the recommended engine oil. Always change the oil filter whenever changing oil.

Pay special attention to the oil level. A rise in oil level during cold weather can indicate contaminants collecting in the oil sump or crankcase. Change oil immediately if the oil level begins to rise. Monitor the oil level, and if it continues to rise, discontinue use and determine the cause. Your dealer can assist.

WARNING

Tractor operation with insufficient, deteriorated, or contaminated engine oil will cause accelerated wear and may result in engine seizure, accident and injury.
Always perform the maintenance procedures as outlined in the Periodic Maintenance Chart.

OIL RECOMMENDATIONS

EGIMOTORS recommends the use of EGIMOTORS PS-4 5W-50 4-Cycle Oil or a similar oil. Refer to the Specifications section for capacities.

Oil may need to be changed more frequently if EGIMOTORS PS-4 engine oil is not used. Follow the manufacturer's recommendations for ambient temperature operation. See the EGIMOTORS Products section for part numbers.

NOTICE

Mixing brands or using a non-recommended oil may cause serious engine damage. Always use the recommended oil. Never substitute or mix oil brands.

OIL CHECK

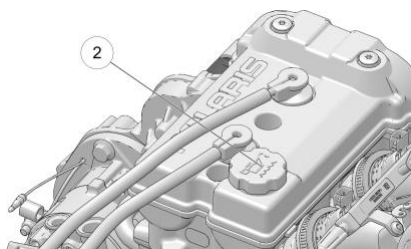
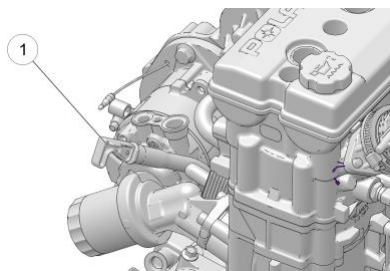

The oil dipstick is located on the engine. Access the dipstick through either the right or left wheel well (depending on your model).

To check the oil, do the following:

1. Position Tractor on a level surface and place the transmission in PARK.
2. Stop the engine and allow it to cool down before removing the dipstick.
3. Raise the cargo box. Unlock the dipstick lever q . Remove the dipstick and wipe it dry with a clean cloth.
4. Reinstall the dipstick and push it into place. Do not lock the dipstick.

NOTICE

Make certain the dipstick is inserted all the way into the dipstick tube to keep the depth of the dipstick consistent.

5. Remove the dipstick and check the oil level.

MAINTENANCE

6. Add the recommended oil as necessary to bring the oil level within the SAFE range on dipstick. Do not overfill (see *NOTICE* below).

NOTICE

A rising oil level between checks during cold weather operation can indicate contaminants such as gas or moisture collecting in the crankcase. If the oil level is over the upper mark, change the oil immediately.

7. With the cargo box raised, add engine oil through the oil fill cap w located on top of the valve cover, under the cargo box.
8. When finished, reinstall dipstick and lock the lever. Lower the cargo box and secure in position.

ENGINE OIL AND FILTER REPLACEMENT

Always change engine oil and filter at the intervals outlined in the Periodic Maintenance Chart. Always change the oil filterq whenever changing the engine oil.

The engine oil dipstick is located on the right front side of the engine. The engine oil fill cap is located on top of the valve cover. Access the oil dipstick and oil fill cap by tilting the rear cargo box.

The crankcase drain plugw is located on the bottom of the crankcase. Access the drain plug through the skid plate access hole located directly under the crankcase.

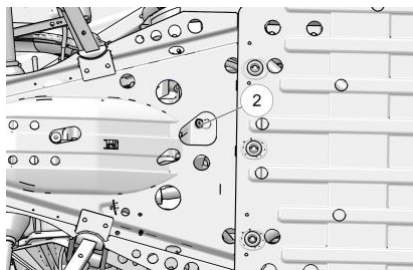
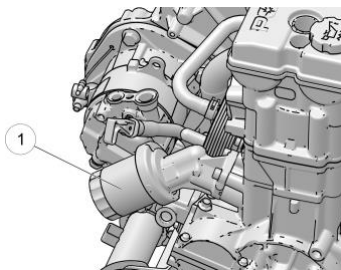

1. Position Tractor on a level surface and place the transmission in PARK.
2. Stop the engine and allow it to cool down.
3. Clean the area around the crankcase drain plug.

CAUTION

Use caution when performing this procedure. Do not allow hot engine oil to come into contact with skin, as serious burns may result.

- Place a drain pan under the engine crankcase and remove the drain plug. Allow the oil to drain completely.
- Remove all cargo from the cargo box.

 **CAUTION**

Always remove all cargo from the cargo box before lifting the box to access the engine.

- Pull up on the cargo box release lever to tilt the box.
- Using the Oil Filter Wrench, turn the oil filter w counter-clockwise to remove it.
- Using a clean dry cloth, clean the filter sealing surface on the engine crankcase.
- Lubricate the O-ring on the new oil filter with a film of fresh engine oil. Check to make sure the O-ring is in good condition. Install it to specification.

TORQUE

Oil Filter

Turn by hand until filter O-ring contacts sealing surface, then turn an additional 3/4 turn.

- Replace the sealing washer on drain plug.

NOTICE

The sealing surface on the drain plug should be clean and free of burrs, nicks or scratches.

- Reinstall the engine crankcase drain plug. Torque drain plug to specification.

TORQUE

Crankcase Drain Plug

16 N·m (12 ft-lbs)

- Remove oil fill cap. Fill engine with recommended engine oil.
 - Verify the transmission is still in PARK.
 - Start the engine and allow it to idle for 30 seconds.
 - Stop the engine and inspect for oil leaks. Wait at least 15 seconds before removing the dipstick.
-

MAINTENANCE

16. Unlock the dipstick lever. Remove the dipstick and wipe it dry with a clean cloth.
17. Reinstall the dipstick and push it into place. Do not lock the dipstick.

NOTICE

Make certain the dipstick is inserted all the way into the dipstick tube to keep the depth of the dipstick consistent.

18. Remove the dipstick and check the oil level.
 19. Add the recommended oil as necessary to bring the oil level within the SAFE range on dipstick. Do not overfill.
 20. When finished, reinstall the oil fill cap, oil dipstick and lock the lever.
 21. Dispose of used oil and filter properly.
-

GEARCASES

GEARCASE SPECIFICATION CHART

GEARCASE	LUBRICANT	CAPACITY	FILL PLUG TORQUE	DRAIN PLUG/ LEVEL CHECK PLUG TORQUE
Transmission (Main Gearcase)	AGL Gearcase Lubricant & Transmission Fluid	51 oz. (1500 ml)	10-14 ft. lbs. (14-19 Nm)	10-14 ft. lbs. (14-19 Nm)
Demand Drive Unit (Front Gearcase)	Demand Drive Fluid	6.8 oz. (200 ml)*	8-10 ft. lbs. (11-13.6 Nm)	11 ft. lbs. (15 Nm)
*If your Tractor is equipped with high mounted intakes: 9.3 oz. (275 ml)				

TRANSMISSION (MAIN GEARCASE)

TRANSMISSION OIL CHECK

Always check and change the transmission oil at the intervals outlined in the Periodic Maintenance Chart. Maintain the oil level even with the bottom thread of the fill plug hole.

The fill plug is located on the rear of the gearcase. Maintain the fluid level at the bottom of the fill plug hole.

To check the transmission fluid, do the following:

1. Position the Tractor on a level surface.
2. Remove the fill plug **q**.
3. Check the fluid level.
4. Add the recommended fluid to the bottom of the fill plug hole. Do not overfill.
5. Reinstall the fill plug. Torque to specification.

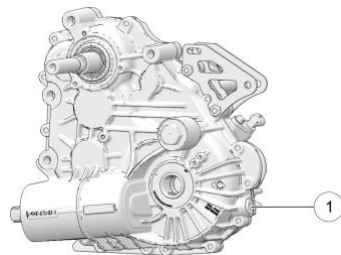

MAINTENANCE

TRANSMISSION OIL CHANGE

The drain plug is located on the bottom of the gearcase. Access the drain plug through the hole in the skid plate.

1. Remove the fill plug q.
2. Place a drain pan under the drain plug w.
3. Remove the drain plug. Allow the fluid to drain completely.
4. Clean and reinstall the drain plug. Torque to specification.
5. Add the recommended fluid to the bottom of the fill plug hole. Do not overfill.
6. Reinstall the fill plug. Torque to specification.
7. Check for leaks. Discard used fluid properly.

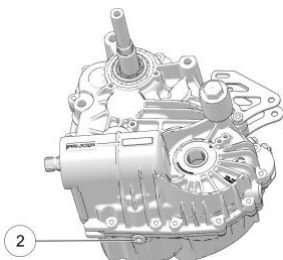

DEMAND DRIVE (FRONT GEARCASE)

DEMAND DRIVE OIL CHECK

Always check and change the demand drive fluid at the intervals outlined in the Periodic Maintenance Chart. Maintain the oil level even with the bottom thread of the fill plug hole. Refer to the Gearcase Specifications Chart for recommended lubricants, capacities and torque specifications.

The front gearcase fill plug q is located on the right side of the front gearcase.

1. Position the Tractor on a level surface.
2. Remove the fill plug q. Check the oil level.
3. Add the recommended oil as needed.
4. Reinstall the fill plug. Torque to specification.

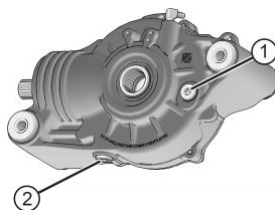

DEMAND DRIVE OIL CHANGE

1. Support the Tractor securely with a jackstand.
 2. Remove the front tire on the passenger's side for ease of access (optional).
 3. Remove the fill plug.
 4. Place a drain pan under the drain plug w on the bottom right-hand side.
 5. Remove the drain plug. Drain the oil.
 6. Clean and reinstall the drain plug. Torque to specification.
 7. Add the recommended fluid to the bottom of the fill plug hole. Do not overfill.
 8. Reinstall the fill plug. Torque to specification.
 9. Check for leaks.
 10. Discard used oil properly.
-

MAINTENANCE

SPARK PLUGS

SPARK PLUG RECOMMENDATIONS

Refer to the Specifications section for the recommended spark plug type for your Tractor. Always torque spark plugs to specification.

NOTICE

Using non-recommended spark plugs can result in serious engine damage. Always use EGIMOTORS-recommended spark plugs or their equivalent.

SPARK PLUG GAP/TORQUE

ELECTRODE GAP	NEW OR USED PLUG TORQUE
0.7 – 0.8 mm	8.6 (12 N·m)

SPARK PLUG INSPECTION

Spark plug condition is indicative of engine operation. The spark plug firing end condition should be read after the engine is warmed up and the Tractor is driven at higher speeds. Immediately check the spark plug for correct color.

CAUTION

A hot exhaust system and engine can cause burns. Wear protective gloves when removing a spark plug for inspection.

To inspect the spark plugs, do the following:

1. Lift the cargo box to access the spark plugs.
2. Remove the spark plug cap. Using the spark plug wrench provided in the tool kit, remove the plug by rotating it counter-clockwise.
3. Reverse the procedure for spark plug installation.
4. Torque to specification.

NORMAL PLUG

The normal insulator tip is gray, tan or light brown. There will be few combustion deposits. The electrodes are not burned or eroded. This indicates the proper type and heat range for the engine and the service.

The tip should not be white. A white insulator tip indicates overheating, caused by use of an improper spark plug or incorrect throttle body adjustments.

WET FOULED PLUG

The wet fouled insulator tip is black. A damp oil film covers the firing end. There may be a carbon layer over the entire nose. Generally, the electrodes are not worn. General causes of fouling are excessive oil, use of non-recommended oil or poor fuel quality.

COOLING SYSTEM

The engine coolant level is controlled or maintained by the recovery system. The recovery system components are the overflow bottle, radiator filler neck, radiator pressure cap and connecting hose.

As coolant operating temperature increases, the expanding (heated) excess coolant is forced out of the radiator, past the pressure cap, and into the overflow bottle. As engine coolant temperature decreases, the contracting (cooled) coolant is drawn back up from the tank, past the pressure cap, and into the radiator.

Some coolant level drop on new Tractors is normal as the system is purging itself of trapped air. Observe coolant levels and maintain as recommended by adding coolant to the overflow bottle.

ADDING OR CHANGING COOLANT

EGIMOTORS recommends the use of EGIMOTORS Antifreeze 50/50 Premix. This antifreeze is already premixed and ready to use. Do not dilute with water.

To ensure that the coolant maintains its ability to protect the engine, we recommend that the system be completely drained every five (5) years and fresh Antifreeze 50/50 Premix added.

Any time the cooling system has been drained for maintenance or repair, replace the coolant with fresh Antifreeze 50/50 Premix. If the recovery bottle has run dry, the level in the radiator should be inspected. Add coolant as needed.

RADIATOR AND COOLING FAN

Always check and clean the screen and radiator fins at the intervals outlined in the Periodic Maintenance Chart. Do not obstruct or deflect air flow through the radiator by installing unauthorized accessories in front of the radiator or behind the cooling fan. Interference with the radiator air flow can lead to overheating and consequent engine damage.

NOTICE

Washing the Tractor with a high-pressure hose could damage the radiator fins and impair the radiator's effectiveness. Using a high-pressure system is not recommended.

MAINTENANCE

RADIATOR COOLANT LEVEL

Always check and clean the screen and radiator fins at the intervals outlined in the Periodic Maintenance Chart. Do not obstruct or deflect air flow through the radiator by installing unauthorized accessories in front of the radiator or behind the cooling fan. Interference with the radiator air flow can lead to overheating and consequentially, engine damage.

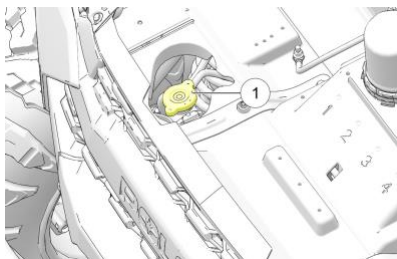

1. Lift the hood.

CAUTION

Escaping steam can cause burns. Never remove the pressure cap while the engine is warm or hot. Always allow the engine to cool before removing the pressure cap.

2. Slowly remove the radiator cap q.
3. View the coolant level through the opening.
4. Use a funnel and slowly add coolant as needed.

TIP

This procedure is required only if the cooling system has been drained for maintenance and/or repair. But if the overflow bottle has run dry, the level in the radiator should also be inspected.

5. Reinstall the pressure cap. Use of a non-standard pressure cap will not allow the recovery system to function properly. Your EGIMOTORS dealer can provide the correct replacement part.

OVERFLOW BOTTLE COOLANT LEVEL

Always check and change the coolant at the intervals outlined in the Periodic Maintenance Chart. Maintain the coolant level between the minimum and maximum marks on the bottle (when the fluid is cool).

1. Position the Tractor on a level surface.
2. Lift the hood. View the coolant level in the overflow bottle w .
3. If the coolant level is below the safe operating range, lift the hood and locate the overflow bottle lid. Remove the cap and use a funnel to add coolant through the filler opening. Reinstall the cap.

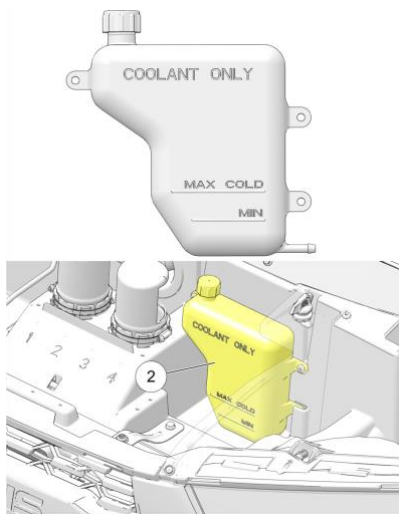

TIP

If coolant must be added often, or if the overflow bottle runs completely dry, there may be a leak in the system. Your dealer can inspect the cooling system.

AIR CONDITIONING

⚠ WARNING

Only licensed and certified professionals are allowed to check and maintain AC refrigerant levels. Your EGIMOTORS dealer can assist.

FILTER CLEANING

The air conditioning filter is located below the center hood.

1. Remove the two fasteners and remove the filter cover.
2. Clean the filter with low air pressure. Check for damage, replace if damaged.

CONDENSER CLEANING

NOTICE

Washing the Tractor with a high-pressure hose could damage the radiator fins and impair the radiator's effectiveness. Using a high-pressure system is not recommended.

MAINTENANCE

The condenser should be cleaned at the correct service interval as outlined in the Periodic Maintenance Chart. The condenser is located at the front of the Tractor, behind the front grille.

To clean the condenser, do the following:

1. Stop the machine on a flat level surface. Place the gear selector in PARK. Stop the engine and exit the Tractor.
2. Remove the front grille of the Tractor by pushing down on the two grille tabs q and pull the top of the grille toward the front of the Tractor.
3. Use low pressure air or water to clean the condenser.
4. Reinstall the front grille and ensure it is snapped into place.

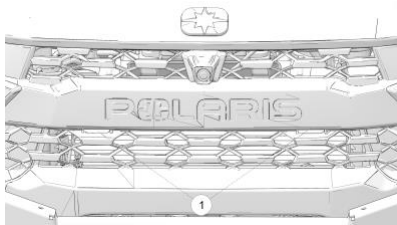

EGIMOTORS VARIABLE TRANSMISSION (PVT) SYSTEM

 **WARNING**

Failure to comply with the instructions in this warning can result in severe injury or death. Do not modify any component of the PVT system. Doing so may reduce its strength so that a failure may occur at a high speed. The PVT system has been precision balanced. Any modification will cause the system to be out of balance, creating vibration and additional loads on components.

The PVT system rotates at high speeds, creating large amounts of force on clutch components. As the owner, you have the following responsibilities for your own safety and the safety of others:

- Always follow all recommended maintenance procedures. Always look for and remove debris inside and around the clutch and vent system when replacing the belt.
 - See your dealer or other qualified service person as outlined in the owner's manual.
 - This PVT system is intended for use on EGIMOTORS products only. Do not install it in any other product.
 - Always make sure the PVT housing is securely in place during operation.
-

MAINTENANCE

BELT REMOVAL

If a belt fails, always clean any debris from the clutch air duct and from the clutch and engine compartments when replacing the belt.

WARNING

Failure to remove ALL debris when replacing the belt could result in Tractor damage, loss of control and severe injury or death.

NOTICE

Inspect the entire clutch outlet duct (including the outlet duct screen) when replacing a drive belt. Remove any debris found in the outlet duct or outlet duct screen.

To remove the belt, do the following:

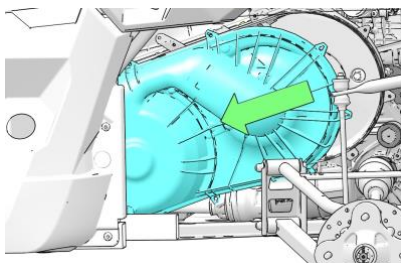
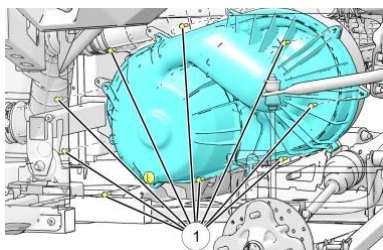

1. Remove the nine fasteners q that retain the outer clutch cover.

NOTICE

Removal of left rear wheel or left rear shock is NOT necessary for belt replacement.

2. Pull the clutch cover forward and slide towards the front of the Tractor as shown above.

3. Rotate the clutch cover back and lift up and over the control arm mounting w.

NOTICE

Use care when lifting clutch cover upwards. Do not damage cover, intake boot, or electrical harness.

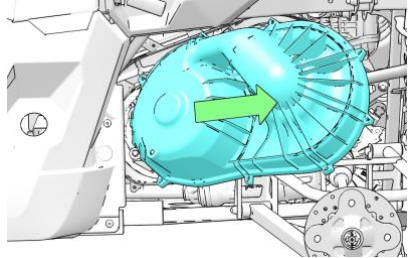
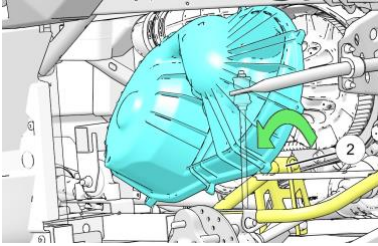

4. Pull clutch cover out towards the rear of the Tractor as shown above.
5. Mark the drive belt direction of rotation so that it can be installed in the same direction.
6. Insert clutch spreader tool e into threaded hole on driven clutch as shown and turn clockwise to spread clutch.

NOTICE

Clutch spreader tool part number 2875911 is found in Tractor tool kit.

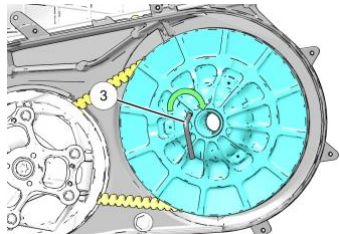

7. Walk the belt out of the driven clutch and drive clutch. Remove the belt from the Tractor.

MAINTENANCE

BELT INSPECTION

To inspect the drive belt, do the following:

1. Inspect belt for hour-glassing (extreme circular wear in at least one spot and on both sides of the belt). Hour glassing occurs when the drive train does not move and the drive clutch engages the belt.
2. Inspect belt for loose cords, missing cogs, cracks, abrasions, thin spots, or excessive wear. Compare belt measurements with a new drive belt. Replace if necessary.
3. Belts with thin spots, burn marks, etc., should be replaced to eliminate noise, vibration, or erratic PVT operation.

BELT INSTALLATION

NOTICE

Be sure to install belt in the same direction as it was removed.

1. With the clutch spreader tool *q* installed, loop the belt over the drive clutch and over the driven clutch.

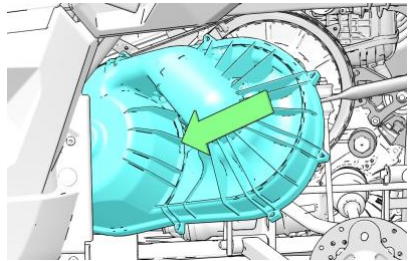
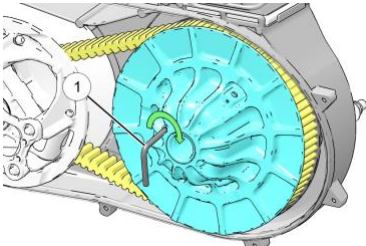

2. Rotate the driven clutch and walk the belt into the clutch.
 3. Remove the clutch spreader tool from driven clutch.
 4. Rotate / spin the driven clutch and belt approximately 5-7 times to properly seat the belt in the driven clutch.
 5. Install the clutch cover into wheel well as shown above.
 6. Rotate clutch cover over A-Arm *w* as shown below. Use care not to damage intake boots or electrical harness.
-

7. Pull clutch cover backwards and align with bolt holes on inner clutch cover as shown below.

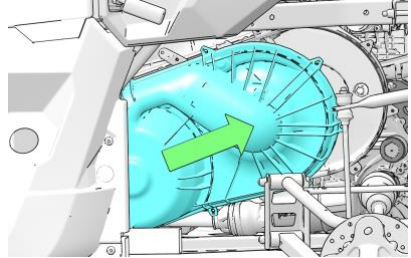
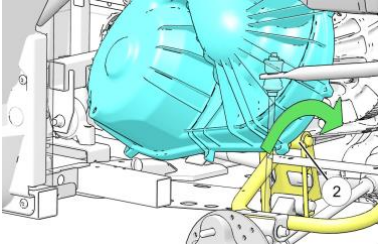

8. Install and torque the outer clutch cover bolts to specification.

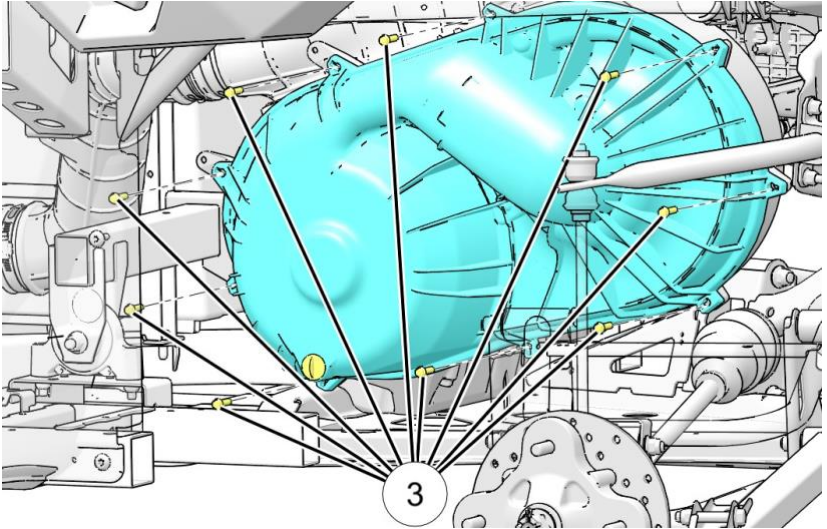

TORQUE

PVT Outer Cover Fasteners: 35 (4 N·m)

MAINTENANCE

EGIMOTORS VARIABLE TRANSMISSION (PVT) DRYING

There may be some instances when water is ingested into the PVT system. Use the following instructions to dry it out before operating:

1. Position the Tractor on a level surface.
 2. Remove the red drain plug on the outer clutch cover. Allow the water to drain completely. Reinstall the drain plug.
 3. Place the transmission in PARK.
 4. Start the engine.
 5. Apply varying throttle for 10-15 seconds to expel the moisture and air-dry the belt and clutches. Do not hold the throttle wide open for more than five (5) seconds.
 6. Allow the engine RPM to settle to idle speed. Apply the brakes. Shift the transmission to the lowest available range.
 7. Test for belt slippage. If the belt slips, repeat the process.
 8. Your Tractor requires service as soon as possible. Your EGIMOTORS dealer can assist.
-

TRACTOR IMMERSION

 **WARNING**

If your Tractor becomes immersed, major engine damage can result if the machine is not thoroughly inspected. Take the Tractor in for service before starting the engine. Your EGIMOTORS dealer can provide this service.

If it's impossible to take your RANGER to a dealer before starting it, follow the steps outlined below:

1. Move the Tractor to dry land or at the very least, to water below the floorboard (or to water below seat base level if your Tractor is equipped with high mounted intakes).
 2. Dry any water present in the air box. Filter replacement is required if water is present.
 3. Remove the spark plugs. Turn the engine over several times using the electric start.
 4. Dry the spark plugs and reinstall, or replace with new plugs.
 5. Attempt to start the engine. If necessary, repeat the drying procedure.
 6. Take the Tractor in for service as soon as possible, whether you succeed in starting it or not. Your EGIMOTORS dealer can provide the required service.
 7. If water has been ingested into the PVT follow the procedure for drying.
-

MAINTENANCE

FILTER SYSTEMS

AIR FILTER REPLACEMENT

Inspect the air filter at the intervals outlined in the Periodic Maintenance Chart. In extremely dusty conditions, air filter replacement will be required more often.

1. Tilt the rear cargo box to access the airbox.
2. Release the five airbox cover latches and lift the cover up and out to access the air filter element.

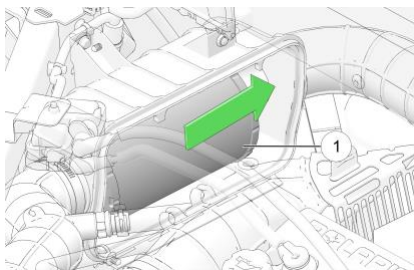
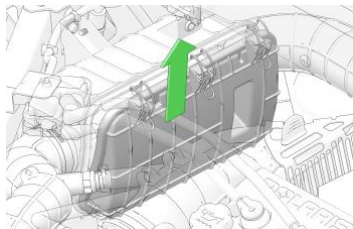
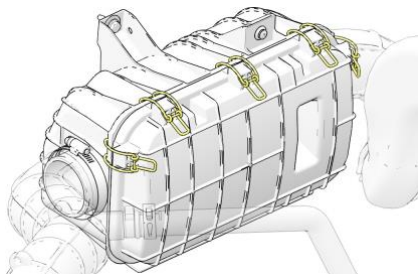

3. Remove the air filter element q.
4. Inspect the airbox for oil or water deposits. Wipe away any deposits with a clean shop towel.

NOTICE

If the filter has been soaked with fuel or oil it must be replaced.
DO NOT attempt to clean the air filter.

5. Place the air filter into the airbox. Reposition the lower airbox cover and install the three retaining latches.

NOTICE

Make sure the hinge pins are properly seated when reassembling the airbox

SPARK ARRESTER

WARNING

- Never operate the Tractor without the spark arrester.
- Remove any combustible materials from the area.

Failure to heed the following warnings while servicing the spark arrester could result in serious injury or death.

- Never run the engine in an enclosed area. Exhaust contains poisonous carbon monoxide gas that can cause loss of consciousness or death in a very short time.
- Do NOT perform service on the spark arrester while the system is HOT. Exhaust system temperatures can reach extreme temperatures. Allow components to cool sufficiently before proceeding.
- Do not stand behind or in front of the Tractor while purging the exhaust system.
- Never go under the Tractor while it is inclined.
- Wear eye protection and gloves while servicing.

Use the following procedure to periodically purge accumulated carbon from the exhaust pipe.

1. Turn off engine and allow exhaust to cool sufficiently.
2. Remove the spark arrester from the tailpipe of the muffler.
3. Remove any debris from spark arrester and the tailpipe.
4. Inspect spark arrester for holes in mesh screen. Replace as needed.
5. Replace spark arrester and torque bolt to specification.

TORQUE

Spark Arrester Bolt
10 ft-lbs (14 N·m)

BRAKES

The front and rear brakes are hydraulic disc type brakes. Press down on the brake pedal to engage the brakes.

BRAKE FLUID

Inspect the brake system routinely. Inspect the level of the brake fluid before each operation.

MAINTENANCE

WARNING

After opening a bottle of brake fluid, always discard any unused portion. Never store or use a partial bottle. Brake fluid is hygroscopic, meaning it rapidly absorbs moisture from the air. The moisture causes the boiling temperature of the brake fluid to drop, which can lead to early brake fade and the possibility of accident or severe injury.

Change the brake fluid every two years and any time the fluid becomes contaminated, the fluid level is below the minimum, or if the type and brand of the fluid in the reservoir are unknown.

1. Position the Tractor on a level surface and turn off the engine.
2. View the brake fluid level q at the reservoir in the driver's side wheel well. The level should be between the upper (MAX) and lower (MIN) level lines.

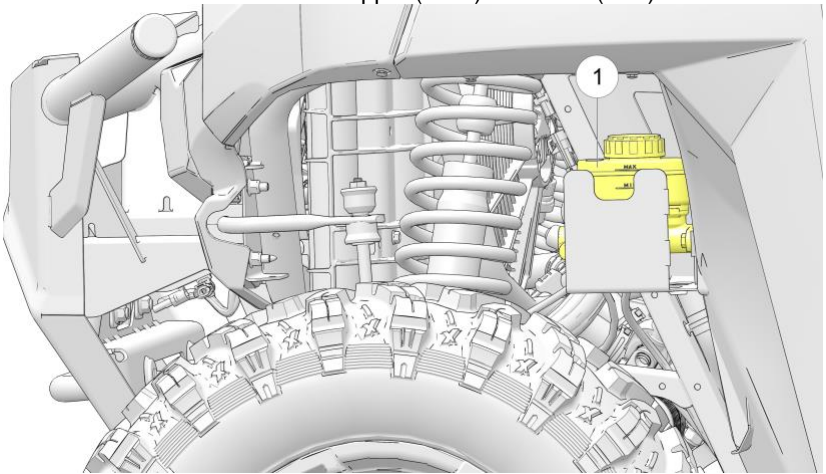

3. If the fluid level is lower than the upper level line, remove the master cylinder cap and add brake fluid to the upper (MAX) line.
4. Apply the brake forcefully for a few seconds and check for fluid leakage around the fittings.

BRAKE INSPECTION

WARNING

Do not apply WD-40® or any petroleum product to brake discs. These types of products are flammable and may also reduce the friction between the brake pad and caliper.

WARNING

Brake components get hot with prolonged use and can cause burns. Wear protective gloves when inspecting the brakes.

1. Check the brake system for fluid leaks.
2. Check the brake pedal for excessive travel or a spongy feel.
3. Check the friction pads for wear, damage and looseness.
4. Check brake discs for signs of cracks, excessive corrosion, warping or other damage. Clean any grease using an approved brake cleaner or alcohol.
5. Inspect the brake disc spline and pad wear surface q for excessive wear. Change pads when worn to 0.030" (0.762 mm).

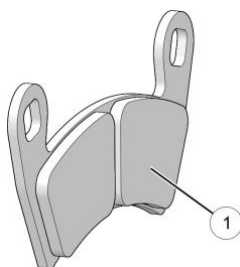

MAINTENANCE

STEERING WHEEL INSPECTION

Check the steering wheel for specified freeplay and smooth operation at the intervals outlined in the Periodic Maintenance Chart section.

1. Position the Tractor on level ground.
2. Lightly turn the steering wheel left and right.
3. There should be 0.8-1.0 in (20-25 mm) of freeplay.
4. If there is excessive freeplay or strange noises, or the steering feels rough or “catchy,” have the steering system inspected by an authorized dealer.

SUSPENSION ADJUSTMENT

The front and rear suspensions can be adjusted to provide a stiffer suspension, if necessary.

1. Remove the top shock mounting bolts from the inside mounting positions **q**.
2. Reposition the shocks to the outside mounting holes **w**.
3. Reinstall the shock mounting bolts. Torque to 40 ft-lbs (54.2 Nm).

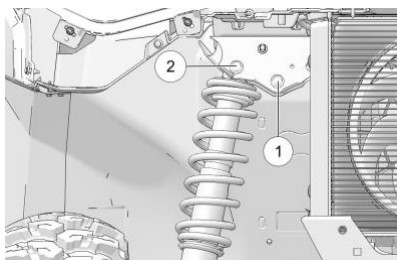

CAM ADJUSTMENT

NOTICE

Trail Boss and NorthStar Trail Boss models are equipped with Nivomat shocks, which cannot be manually adjusted. Nivomat shocks automatically adjust internal pressure during use

Adjust the front and rear shock absorber springs by rotating the adjustment cam either clockwise or counter-clockwise to increase or decrease spring tension.

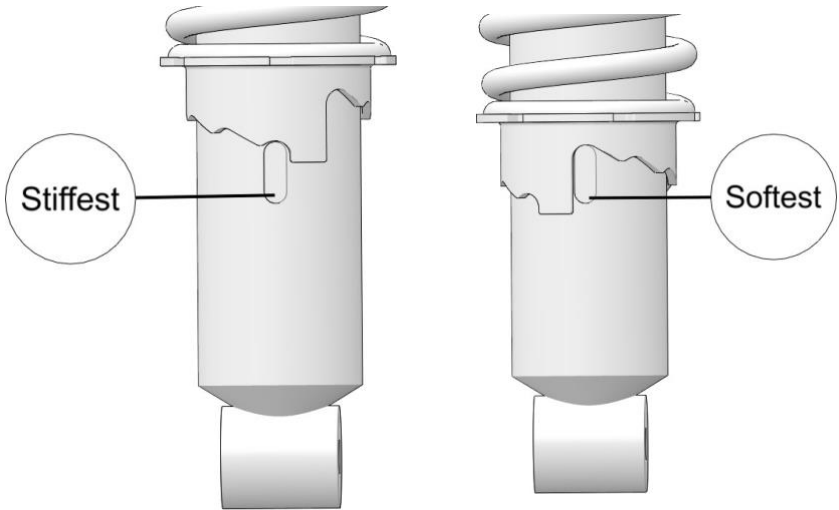

Always heed the following rules if you make adjustments to this suspension.

- Always return the suspension to the lowest (softest) setting after the load is removed from the Tractor. The increased suspension height will negatively impact Tractor stability when operating without a load.
- Always apply the same adjustment setting to both rear wheels.

MAINTENANCE

TIRES

WARNING

Operating your Tractor with worn tires will increase the possibility of skidding, loss of control and an accident, which could result in serious injury or death. Always replace tires when the tread depth measures 1/8 in (3 mm) or less. Improper tire inflation or the use of non-standard size or type of tires may adversely affect Tractor handling, which could result in Tractor damage or personal injury. Always maintain proper tire pressure. Always use EGIMOTORS approved size and type of tires for this Tractor when replacing tires.

TIRE TREAD DEPTH

Always replace tires when tread depth is worn to 3 mm (1/8") or less.

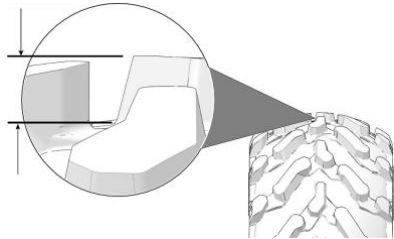

AXLE AND WHEEL NUT TORQUE SPECIFICATIONS

Inspect the following items occasionally for tightness, and if they've been loosened for maintenance service. Do not lubricate the stud or the lug nut.

Lug Nut (Aluminum Wheels)		Front and Rear	120 ft-lbs (163 Nm)
Spindle Nut		Front	180 ft. lbs. (245 N·m)
Hub Retaining Nut		Rear	180 ft. lbs. (245 N·m)

WHEEL REMOVAL

1. Position the Tractor on a level surface.
2. Apply the brakes. Set the park brake. Turn the key off.
3. Loosen the wheel nuts slightly.
4. Elevate the side of the Tractor by placing a suitable stand under the frame.
5. Remove the wheel nuts. Remove the wheel.

WHEEL INSTALLATION

 **WARNING**

Improperly installed wheels can adversely affect tire wear and Tractor handling, which can result in serious injury or death. Always ensure that all nuts are torqued to specification. Do not service axle nuts that have a cotter pin installed. Your dealer can assist.

1. Place the transmission in PARK.
 2. Place the wheel on the hub with the valve stem toward the outside and rotation arrows on the tire pointing toward forward rotation.
 3. Attach the wheel nuts and finger-tighten.
 4. Carefully lower the Tractor to the ground.
 5. Torque the wheel nuts to specification.
-

MAINTENANCE

LED LIGHTS (IF EQUIPPED)

LIGHTS

Poor lighting can result in reduced visibility when driving. Headlight and taillight lenses become dirty during normal operation. Clean lights frequently and replace failed (or failing) lights promptly. Do not operate this Tractor at night or in low light conditions until the headlight is replaced. Always make sure lights are adjusted properly for best visibility.

The Tractor is equipped with integrated LED lights. In the event of a failure, the entire assembly must be replaced.

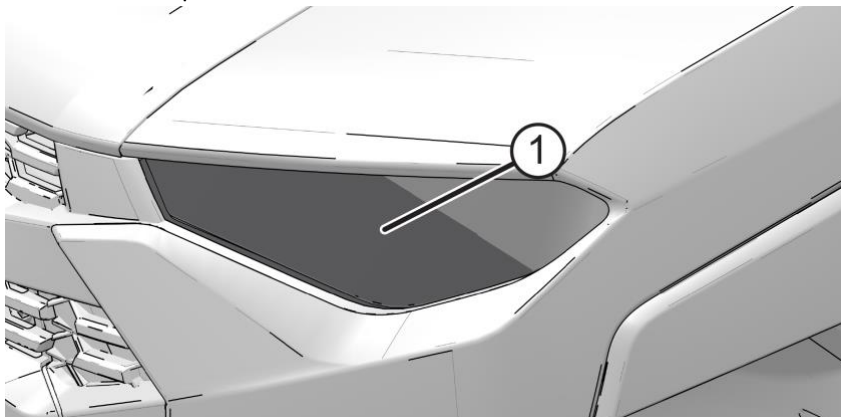

HALOGEN LIGHTS (IF EQUIPPED)

LIGHTS

Poor lighting can result in reduced visibility when driving. Headlight and taillight lenses become dirty during normal operation. Clean lights frequently and replace burned out lamps promptly. Do not operate this Tractor at night or in low light conditions until the headlight is replaced. Always make sure lights are adjusted properly for best visibility.

When servicing a halogen lamp, don't touch the lamp with bare fingers. Oil from your skin leaves a residue, causing a hot spot that will shorten the life of the lamp.

HEADLIGHT BULB REPLACEMENT

1. Remove the hood from the front cab.
2. Locate the bulb on the back side of the headlight housing.
3. Disconnect the harness from the bulb. Be sure to pull on the connector q, not on the wiring.

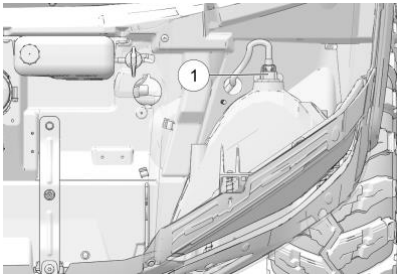

4. Turn the bulb counterclockwise and remove it from the headlight housing, as shown above.
5. Install the new bulb into the housing and rotate it clockwise 90° to lock it in place.

NOTICE

Make sure the tab on the bulb locates properly in the housing.

6. Install the harness onto the new headlight bulb and install the hood.

MAINTENANCE

HEADLIGHT BEAM ADJUSTMENT

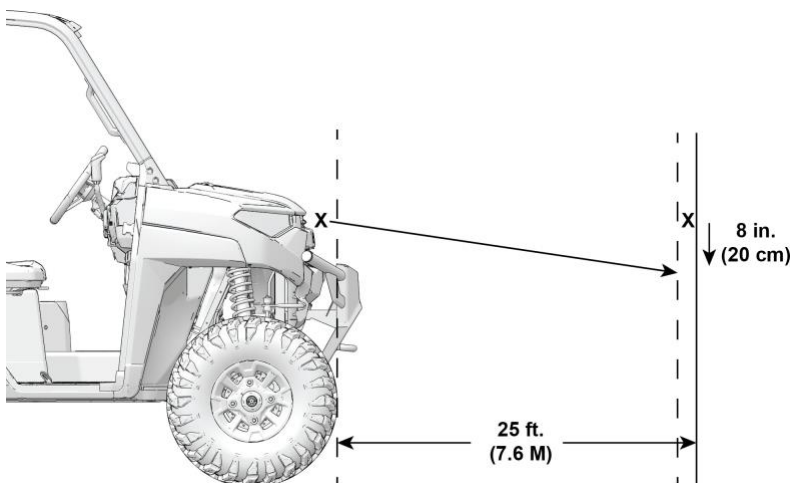

To adjust the headlight beam, do the following:

1. Ensure the tire pressure of all tires is at recommended levels.
2. Place the Tractor on a level surface with the headlight approximately 25 ft. (7.6 m) from a dark wall.
3. Measure the distance from the floor to the center of the headlight and make a mark on the wall at the same height.
4. Apply the brakes. Start the engine. Turn on the low-beam headlights.
5. Observe the headlight aim. The most intense part of the headlight beam should be aimed 8" (20 cm) below the mark placed on the wall. Include the weight of a rider on the seat while performing this step.
6. If a headlight needs adjustment, locate the three adjustment screws at the back of each headlight (one on top, two on the bottom).
7. Rotate the adjustment screw to adjust the headlight as needed.

BRAKE LIGHTS

When the brake pedal is depressed, the brake light comes on. Check the brake light before each ride.

To check the brake lights, do the following:

1. Turn the key to the ON position.
2. Depress the brake pedal. The brake light should come on after about 0.4 in (10 mm) of pedal travel. If the light doesn't come on, check the bulb.

MAINTENANCE

FUSES

If the engine stops or will not start, or if you experience other electrical failures, a fuse may need replacement. Locate and correct any short circuits that may have caused the blown fuse, then replace the fuse. To access the fuse box, remove the storage bin under the center rear-most seat. Spare fuses are provided in the fuse box. If you suspect that a fuse or relay may not be working properly, your dealer can assist.

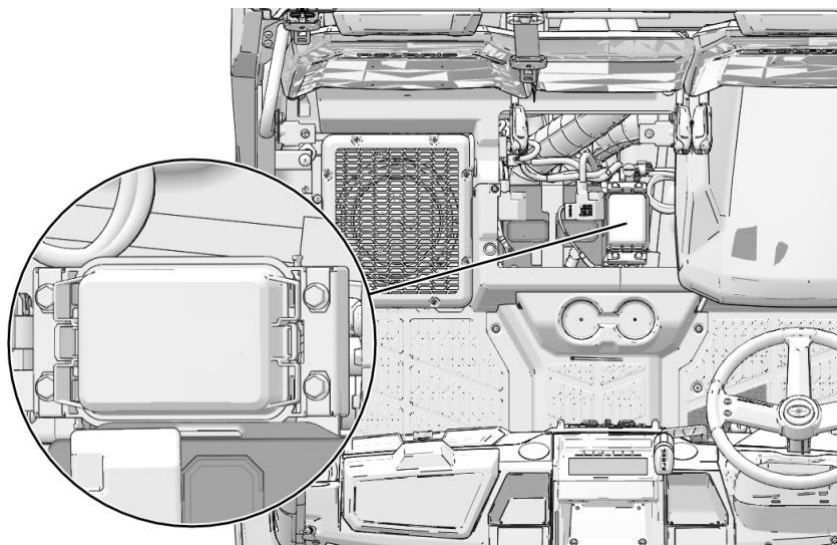

PREMIUM / CREW, HD, AND MD CREW MODELS

FUSE SIZE	FEATURE SUPPORTED
20A	Accessory
15A	Lights
7.5A	Winch
10A	Key Switch
10A	Trickle Charge
15A	Drive
7.5A	Display
20A	Chassis
30A	EPS

FUSE SIZE	FEATURE SUPPORTED
10A	ECM
20A Circuit Breaker	Fan
20A	Box Power (HD Models Only)

NORTHSTAR PREMIUM / CREW, NORTHSTAR TRAIL BOSS / CREW, AND NORTHSTAR ULTIMATE / CREW MODELS

NorthStar models come equipped with an external 50A fuseq for the fan. The fuse is located on the battery tray.

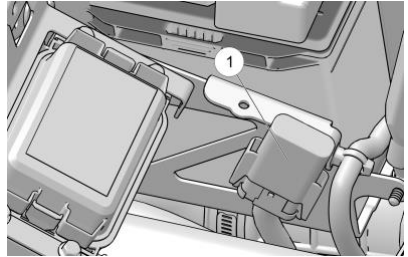

FUSE SIZE	FEATURE SUPPORTED
7.5A	Winch
10A	ECM
30A	EPS
20A	Accessory
15A	Drive
20A	Chassis
15A	Alternator (S)
15A	Alternator (L)
20A	Amp
10A	Key Switch
7.5A	Display
30A	HVAC
7.5A	HVAC 2

MAINTENANCE

FUSE SIZE	FEATURE SUPPORTED
15A	Lights
10A	Trickle Charge
20A	Box Power
50A	Fan

BATTERY

 **WARNING**

Battery electrolyte is poisonous. It contains sulfuric acid. Serious burns can result from contact with skin, eyes or clothing.

Antidote:

External: Flush with water.

Internal: Drink large quantities of water or milk. Follow with milk of magnesia, beaten egg, or vegetable oil. Call physician immediately.

Eyes: Flush with water for 15 minutes and get prompt medical attention.

Batteries produce explosive gases. Keep sparks, flame, cigarettes, etc. away. Ventilate when charging or using in an enclosed space. Always shield eyes when working near batteries. **KEEP OUT OF REACH OF CHILDREN.**

Your Tractor has a low-maintenance flooded battery. It does not require refilling.

Always keep battery terminals and connections free of corrosion. If cleaning is necessary, remove the corrosion with a stiff wire brush. Wash with a solution of one tablespoon baking soda and one cup water. Rinse well with tap water and dry off with clean shop towels. Coat the terminals with dielectric grease or petroleum jelly. Be careful not to allow cleaning solution or tap water into a conventional battery.

 **WARNING**

Improperly connecting or disconnecting battery cables can result in an explosion and cause serious injury or death. When removing the battery, always disconnect the negative (black) cable first. When reinstalling the battery, always connect the negative (black) cable last.

MAINTENANCE

BATTERY MAINTENANCE AND CHARGING

WARNING

An overheated battery may explode, causing severe injury or death. Always watch charging times carefully. Stop charging if the battery becomes very warm to the touch. Allow it to cool before resuming charging.

The sealed battery is already filled with electrolyte and has been sealed and *fully charged* at the factory. *Never* pry the sealing strip off or add any other fluid to this battery.

The single most important thing about maintaining a sealed battery is to keep it fully charged. Check the battery voltage with a voltmeter or multimeter. A fully charged battery will register 12.8 V or higher. If the voltage falls below 12.5V, charge it immediately, or the battery runs the risk of sulfation and reduced battery life.

If you do not drive the Tractor for more than TWO WEEKS, EGIMOTORS recommends using a BatteryMINDER® 2012 AGM - 2 AMP charger (PN 2830438), which can be ordered through your dealer.

EGIMOTORS provides a charging accessory with your Tractor that allows easy connection to the battery through the 12V auxiliary outlet, located on the dash. During charging, place the charger outside of the Tractor and protect it from moisture.

IMPORTANT

The 12V socket located in the rear of 4 seat Tractors is powered after key-on and **CANNOT** be used for charging.

If you plan to store the Tractor for ONE MONTH or longer, remove the battery from the Tractor, then store the battery in a cool and dry location. Continue to maintain the battery with the BatteryMINDER® 2012 AGM - 2 AMP charger.

When using an automatic charger other than a BatteryMINDER® 2012-AGM - 2 AMP charger, refer to the charger manufacturer's instructions for recharging.

If using a **constant current charger** (instead of BatteryMINDER® 2012 AGM - 2 AMP charger), use the guidelines below. Always verify battery condition before and 1-2 hours after the end of charging.

MAINTENANCE

STATE OF CHARGE	VOLTAGE (DC)	ACTION	CHARGE TIME*
100%	12.8-13.0 volts	None, check monthly	None required
75%-100%	12.6-12.8 volts	May need slight charge, if no charge given, check in 2 weeks	3-6 hours
50%-75%	12.3-12.6 volts	Needs charge	5-11 hours
25%-50%	12.0-12.3 volts	Needs charge	At least 13 hours
0%-25%	12.0 volts or less	Needs charge	At least 20 hours

* Using AGM specific charger at standard amps specified on top of battery

BATTERY REMOVAL

WARNING

Improperly connecting or disconnecting battery cables can result in an explosion and cause serious injury or death. When removing the battery, always disconnect the negative (black) cable first. When reinstalling the battery, always connect the negative (black) cable last.

To remove the battery, do the following:

1. Remove the storage bin under the center rear-most seat to access the battery.
2. Disconnect the black (-) battery cable first. Disconnect the red (+) battery cable last.
3. Remove the battery hold-down strap.
4. Lift the battery out of the Tractor. Be careful not to tip a flooded battery sideways, which could spill electrolyte.

NOTICE

If electrolyte spills, immediately wash it off with a solution of one tablespoon baking soda and one cup water to prevent damage to the Tractor.

MAINTENANCE

BATTERY INSTALLATION

1. Ensure that the battery is fully charged.
2. Place the battery in the battery holder.
3. Coat the terminals with dielectric grease or petroleum jelly.
4. Connect and tighten the red (positive) cable first.
5. Connect and tighten the black (negative) cable last.
6. Install the battery hold-down strap and tighten the screws.
7. Verify that cables are properly routed.
8. Reinstall the seat.

BATTERY STORAGE

Whenever the Tractor is not used for a period of three months or more, remove the battery from the Tractor, ensure that it's fully charged, and store it out of the sun in a cool, dry place. Check battery voltage each month during storage and recharge as needed to maintain a full charge.

TIP

Battery charge can be maintained by using a EGIMOTORS battery trickle charger or by charging about once a month to make up for normal self discharge. The battery trickle charger can be left connected during the storage period, and will automatically charge the battery if the voltage drops below a predetermined point.

CLEANING AND STORAGE

WASHING THE TRACTOR

Keeping your EGIMOTORS Tractor clean will not only improve its appearance but it can also extend the life of various components.

NOTICE

High water pressure may damage components. EGIMOTORS recommends washing the Tractor by hand or with a garden hose, using mild soap.

NOTICE

Certain products, including insect repellents and chemicals, will damage plastic surfaces. Do not allow these types of products to contact the Tractor.

The best and safest way to clean your EGIMOTORS Tractor is with a garden hose and a pail of mild soap and water.

1. Use a professional-type washing cloth, cleaning the upper body first and the lower parts last.
2. Rinse with clean water frequently.
3. Dry surfaces with a chamois to prevent water spots.

WASHING TIPS

- Avoid the use of harsh cleaners, which can scratch the finish.
- Do not use a power washer to clean the Tractor.
- Do not use medium to heavy duty compounds on the finish.
- Always use clean cloths and pads for cleaning and polishing. Old or reused cloths and pads may contain dirt particles that will scratch the finish.
- Grease all zerk fittings immediately after washing. Allow the engine to run for a while to evaporate any water that may have entered the engine or exhaust system.

If a high pressure water system is used for cleaning (not recommended), exercise extreme caution. The water may damage components and could remove paint and labels. Avoid directing the water stream at the following items:

- Wheel bearings
- Radiator
- Transmission seals
- Brakes
- Door seals (if equipped)
- Cab and body panels
- Labels and decals
- Electrical components and wiring
- Air intake components
- Window seals (if equipped)

MAINTENANCE

If an informational or graphic label becomes illegible or comes off, contact your EGIMOTORS dealer, or other qualified person, to purchase a replacement. Replacement safety labels are provided by EGIMOTORS at no charge.

STORAGE TIPS

NOTICE

Starting the engine during the storage period will disturb the protective film created by fogging and damage could occur. Never start the engine during the storage period.

CLEAN THE EXTERIOR

Make any necessary repairs and clean the Tractor as recommended.

STABILIZE THE FUEL

1. Fill the fuel tank.
2. Add EGIMOTORS Carbon Clean Fuel Treatment or EGIMOTORS Fuel Stabilizer or equivalent fuel treatments or stabilizers. Follow the instructions on the container for the recommended amount. Carbon Clean removes water from fuel systems, stabilizes fuel and removes carbon deposits from pistons, rings, valves and exhaust systems.
3. Allow the engine to run for 15-20 minutes to allow the stabilizer to disperse through the entire fuel delivery system.

OIL AND FILTER

Change the oil and filter. See the Engine Oil section.

AIR FILTER / AIR BOX

Replace the air filter. See Maintenance Chapter. Clean the air box.

FLUID LEVELS

Inspect the fluid levels. Add or change fluids as recommended in the Periodic Maintenance Chart.

- Demand drive fluid (front gearcase)
 - Rear gearcase fluid (if equipped)
 - Transmission fluid
 - Brake fluid (change every two years and any time the fluid looks dark or contaminated)
 - Coolant (test strength/fill)
-

INSPECT AND LUBRICATE

Inspect all cables and lubricate all areas of the Tractor as recommended in the Periodic Maintenance Chart.

FOG THE ENGINE

1. Treat the fuel system with EGIMOTORS Carbon Clean or other equivalent fuel treatment. Follow the instructions on the container. Start the engine. Allow it to idle for several minutes so the Carbon Clean reaches the injectors. Stop the engine.
2. Remove the spark plugs and add 1–1.5 oz. (29.5–44 cc.) of engine oil. To access the plug holes, use a section of clear 6 mm (1/4") hose and a small plastic squeeze bottle filled with the pre-measured amount of oil. *Do this carefully! If you miss the plug holes, oil will drain from the spark plug cavities into the hole at the front of the cylinder head, and appear to be an oil leak.*
3. Reinstall the spark plugs. Torque to specification.
4. Apply dielectric grease to the inside of each spark plug cap. *Do not reinstall the cap onto the plug at this step.*
5. Turn the engine over several times. Oil will be forced in and around the piston rings and ring lands, coating the cylinder with a protective film of fresh oil.
6. Reinstall the spark plug caps.
7. If EGIMOTORS fuel system additive is not used, fuel tank, fuel lines, and injectors should be completely drained of gasoline.

STORAGE AREA / COVERS

Be sure the storage area is well ventilated. Cover the Tractor with a genuine EGIMOTORS cover. Do not use plastic or coated materials. They do not allow enough ventilation to prevent condensation, and may promote corrosion and oxidation.

MAINTENANCE

REMOVAL FROM STORAGE



Engine exhaust contains poisonous carbon monoxide and can cause loss of consciousness or death. Never run an engine in an enclosed area.

1. Check the battery electrolyte level and charge the battery if necessary. Install it in the Tractor. Make sure the battery vent hose is routed properly and that it's not pinched or restricted in any way.
2. Make sure spark plugs are tight.
3. Fill the fuel tank with fuel.
4. Check all the points listed in the Daily Pre-Ride Inspection. *Tightness of the bolts, nuts and other fasteners should be checked by an authorized dealer or other qualified service facility.*
5. Lubricate at the intervals outlined in the Periodic Maintenance Chart.

TRANSPORTING THE TRACTOR

Follow these procedures when transporting the Tractor.

1. Apply the brakes.
2. Place the transmission in PARK. Stop the engine.
3. Slowly release the brake pedal and make sure the transmission is in PARK before exiting the Tractor.
4. Remove the key to prevent loss during transporting.
5. Secure the fuel cap and seat. Ensure that the seat is attached correctly and is not loose.



Cargo and other loose Tractor parts may fly off while transporting this Tractor. Secure or remove all cargo, and inspect the unit for loose parts prior to transport.

If transporting the Tractor in a non-enclosed trailer, then the Tractor must **FACE FORWARD**, or roof must be removed.

Failure to comply may allow airflow, vibration, or other factors to separate the roof from the Tractor and cause an accident, resulting in serious personal injury or death.

6. Using suitable straps or rope, always secure the Tractor to the trailer using the designated tie down points (front and rear).
-

Front Tie-Down Location

1 Front tie-down points

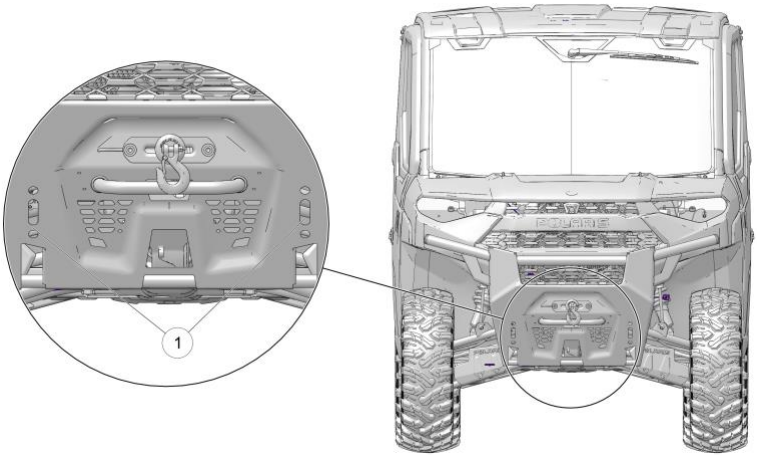

Rear Tie-Down Locations

2 Rear tie-down points

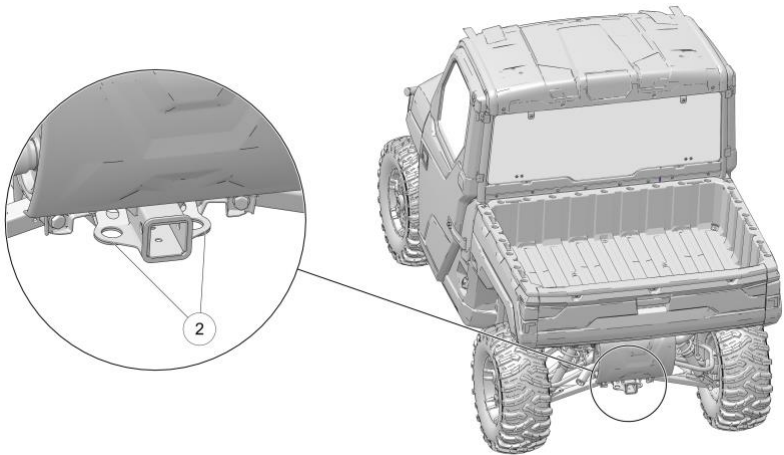

SPECIFICATIONS

RANGER CREW XP 1000

DESCRIPTION	SPECIFICATION
Maximum Weight Capacity (includes weight of operator, passenger, cargo, accessories)	(767 kg)
Dry Weight Estimated	(859kg)
Fuel Capacity	(43.5 L)
Engine Oil Capacity	(2.4 L)
Coolant Capacity	(5.35 L)
Overall Length	(386 cm)
Overall Width	(158 cm)
Overall Height	(196 cm)
Wheelbase	(287 cm)
Cargo Box Dimensions (Inside)	(93 x 138 x 32 cm)
Ground Clearance	(33 cm)
Min. Turning Radius	(396 cm)
Towing Capacity	(750 kg)
Hitch Tongue Capacity	(50 kg)

SPECIFICATIONS

DESCRIPTION	SPECIFICATION
Max. Cargo Box Load	(272 kg)
Engine	4-Stroke DOHC Twin Cylinder
Displacement	999 cc
Bore x Stroke (mm)	93 mm x 73.5 mm
Stator Output	660 W @ 3000 RPM
Compression Ratio	10.8:1
Starting System	Electric
Fuel System	Electronic Fuel Injection
Ignition Timing	ECU Controlled 32° +/- 2° @ 5000 RPM
Spark Plug/ Gap	MR7F / 0.7-0.8 mm
Lubrication System	Wet Sump
Cooling	Liquid
Front Suspension	Dual A-Arm 11.0 in (27.9 cm) Travel
Rear Suspension	Dual A-Arm, IRS 11.0" (27.9 cm) Travel
Ignition System	Digital CDI
Driving System Type	Pro-PVT
Shift Type	Single Lever (H/L/N/R/P)
Gear Reduction - Low	Front 9.65:1/ Rear 28.84:1
Gear Reduction - Reverse	Front 9.16:1 / Rear 27.39:1
Gear Reduction - High	Front 4.35:1 / Rear 13.01:1
Drive Ratio - Front	3.23:1
Tire Size - Front	225/73-14 equal to 27/9-14

SPECIFICATIONS

DESCRIPTION	SPECIFICATION
Tire Size - Rear	275/60-14 equal to 27/11-14
Tire Pressure – Front - bar	1 Bar Light load – 1.5 Bar Full Load
Tire Pressure – Rear- bar	1,4 Bar Light Load – 1.7 Bar Full Load
Brakes, Front/Rear	Foot Activated, 4 wheel hydraulic disc with dual-bore front calipers
Hood Headlights	Halogen 55W Low Beam 60W High Beam
Taillights	LED
Brake Light	LED

LUBRICANTS / SERVICE PRODUCTS

PRODUCT	SIZE (QUANTITY)	QUANTITY	PART NUMBER
Fogging Oil	12 fl oz (355 mL) aerosol	12	2870791
	1 qt (0.95 L)	12	2871517
PS-4	1 qt (0.95 L)	12	2876244
	2 qt (1.90 L)	8	2877490
	1 gal (3.8 L)	4	2876245
PS-4 Extreme Duty	1 qt (0.95 L)	12	2878920
	2 qt (1.90 L)	8	2878922
	1 gal (3.8 L)	4	2878919
AGL	1 qt (0.95 L)	12	2878068
	1 gal (3.8 L)	4	2878069
Pump for Gallon Jug	—	1	2870465
Demand Drive	1 qt (0.95 L)	12	2877922
	2.5 gal (9.5 L)	2	2877923
Antifreeze / Coolant	1 qt (0.95 L)	12	2880514
	1 gal (3.8 L)	6	2880513
Grease Gun Kit, Premium All Season	—	1	2871312
All Season Grease	Four 3 fl oz (89 mL) packs	6	2871322
	14 fl oz (414 mL) cartridge	1	2871423
Premium Starter Grease	—	1	2871460
U-Joint Grease	3 fl oz (89 mL) tube	24	2871515
	14 fl oz (414 mL) cartridge	1	2871551
Dielectric Grease (Nyogel®)	—	1	2871329
Carbon Clean	12 fl oz (355 mL) bottle	12	2871326
Fuel Stabilizer	16 fl oz (473 mL)	12	2870652

SPECIFICATIONS

PRODUCT	SIZE (QUANTITY)	QUANTITY	PART NUMBER
	2.5 gal (9.5 L)	2	2872280
DOT 4 Brake Fluid	—	1	2872189
Loctite® 565 Thread Sealant	—	1	2871956
BatteryMINDer® 2012 AGM - 2 AMP Charger	—	1	2830438

TROUBLESHOOTING

TROUBLESHOOTING

DRIVE BELT WEAR/BURN

POSSIBLE CAUSE	SOLUTION
Driving onto a pickup or tall trailer in high range	Use low range during loading.
Starting out going up a steep incline	Use low range.
Driving at low RPM or ground speed – 3–7 mph (4.8–11.3 km/h)	Drive at a higher speed or use low range more frequently.
Insufficient warm-up at low ambient temperatures	Warm the engine at least 5 minutes. With the transmission in neutral, advance the throttle to about 1/8 throttle in short bursts, 5 to 7 times. The belt will become more flexible and prevent belt burning.
Slow/easy clutch engagement	Use the throttle quickly and effectively.
Towing/pushing at low RPM/low ground speed	Use low range only.
Utility use/plowing	Use low range only.
Stuck in mud or snow	Shift the transmission to low range and carefully use fast, aggressive throttle application to engage clutch. WARNING: Excessive throttle may cause loss of control and Tractor rollover.
Climbing over large objects from a stopped position	Shift the transmission to low range and carefully use fast, brief, aggressive throttle application to engage clutch. WARNING: Excessive throttle may cause loss of control and Tractor rollover.
Belt slippage from water or snow ingestion into the PVT system	Dry out the PVT. Prevent water from entering the PVT intake duct. See Intake Pre-Filters for more information. Inspect clutch seals for damage if repeated leaking occurs.
Clutch malfunction	An authorized dealer can assist.
Poor engine performance	Check for clogged air filter, clogged fuel filter, water in the fuel or foreign material in fuel tank or fuel lines. An authorized dealer can assist.
Slippage from failure to warm up belt	Always warm up the belt by operating below 30 mph (48 km/h) for 1 miles (1.6 km) (5 miles (8 km) or more when temperature is below freezing).
Wrong or missing belt	Install the recommended belt.
Improper break-in	Always break in a new belt and/or clutch.

ENGINE DOESN'T TURN OVER

POSSIBLE CAUSE	SOLUTION
Low battery voltage	Recharge the battery.
Loose battery connections	Check all connections and tighten.
Loose solenoid connections	Check all connections and tighten.
Loose electronic control box connections	Inspect, clean, reinstall connectors.

ENGINE TURNS OVER, FAILS TO START

POSSIBLE CAUSE	SOLUTION
Out of fuel	Refuel.
Water is present in fuel	Drain the fuel system and refuel.
Old or non-recommended fuel	Replace with fresh recommended fuel.
Fouled or defective spark plug	Inspect plug and replace if necessary.
No spark to spark plug	Inspect plug and replace if necessary.
Water or fuel in crankcase	Your authorized dealer can assist.
Low battery voltage	Recharge the battery to 12.8 VDC.
Mechanical failure	Your authorized dealer can assist.

ENGINE BACKFIRES

POSSIBLE CAUSE	SOLUTION
Weak spark from spark plug	Inspect, clean and/or replace spark plug
Incorrect spark plug gap or heat range	Set gap to specs or replace plug
Old or non-recommended fuel	Replace with fresh recommended fuel
Incorrectly installed spark plug wires	Your authorized dealer can assist

TROUBLESHOOTING

POSSIBLE CAUSE	SOLUTION
Mechanical failure	Your authorized dealer can assist
Loose ignition connections	Check all connections and tighten
Water present in fuel	Replace with fresh recommended fuel

ENGINE PINGS OR KNOCKS

POSSIBLE CAUSE	SOLUTION
Poor quality or low octane fuel	Replace with recommended fuel
Incorrect spark plug gap or heat range	Set gap to specs or replace plug

ENGINE RUNS IRREGULARLY, STALLS OR MISFIRES

POSSIBLE CAUSE	SOLUTION
Fouled or defective spark plug	Inspect, clean and/or replace spark plug
Worn or defective spark plug wires	Your authorized dealer can assist
Incorrect spark plug gap or heat range	Set gap to specs or replace plug
Loose ignition connections	Check all connections and tighten
Water present in fuel	Replace with new fuel
Low battery voltage	Recharge battery to 12.8 VDC
Incorrect fuel	Replace with recommended fuel
Clogged air filter	Inspect and clean or replace
Clogged intake pre-filter	Inspect and clean (with soapy water) or replace
Other mechanical failure	Your authorized dealer can assist

ENGINE STOPS OR LOSES POWER

POSSIBLE CAUSE	SOLUTION
Out of fuel	Refuel
Kinked or plugged fuel vent line	Inspect and replace
Water is present in fuel	Replace with new fuel

TROUBLESHOOTING

POSSIBLE CAUSE	SOLUTION
Fouled or defective spark plug	Inspect, clean and/or replace spark plug
Worn or defective spark plug wires	Your authorized dealer can assist
Incorrect spark plug gap or heat range	Set gap to specs or replace plug
Loose ignition connections	Check all connections and tighten
Low battery voltage	Recharge the battery
Incorrect fuel	Replace with fresh recommended fuel
Clogged air filter	Inspect and clean or replace
Clogged intake pre-filter	Inspect and clean (with soapy water) or replace
Other mechanical failure	Your authorized dealer can assist
Overheated engine	Clean radiator screen and core, clean engine exterior, and check coolant level. Your dealer can assist.

WARRANTY

LIMITED WARRANTY

EGIMOTORS gives a TWO-YEAR LIMITED WARRANTY on all components of your Tractor against defects in material or workmanship.

This warranty covers parts and labor charges for repair or replacement of defective parts and begins on the date of purchase by the original retail purchaser.

This warranty is transferable to another owner during the warranty period through a dealer, but any such transfer will not extend the original term of the warranty.

REGISTRATION

At the time of sale, the Warranty Registration Form must be completed by your dealer and submitted to EGIMOTORS within ten days of purchase. Upon receipt of this registration, EGIMOTORS will record the registration for warranty. No verification of registration will be sent to the purchaser as the copy of the Warranty Registration Form will be your proof of warranty coverage. If you have not signed the original registration and received the customer copy, please contact your dealer immediately. **NO WARRANTY COVERAGE WILL BE ALLOWED UNLESS YOUR VEHICLE IS REGISTERED WITH EGIMOTORS.** Initial

dealer preparation and set-up of your vehicle is very important in ensuring trouble-free operation. Purchasing a machine in the crate or without proper dealer set-up will void your warranty coverage.

WARRANTY

WARRANTY COVERAGE AND EXCLUSIONS

LIMITATIONS OF WARRANTIES AND REMEDIES

This EGIMOTORS limited warranty excludes any failures that are not caused by a defect in material or workmanship. THIS WARRANTY DOES NOT COVER CLAIMS OF DEFECTIVE DESIGN. This warranty also does not cover acts of God, accidental damage, normal wear and tear, abuse or improper handling. This warranty also does not cover any vehicle, component, or part that has been altered structurally, modified, neglected, improperly maintained or used for racing, competition or purposes other than for which it was designed.

This warranty excludes damages or failures resulting from improper lubrication; improper engine timing; improper fuel; surface imperfections caused by external stress, heat, cold or contamination; operator error or abuse; improper component alignment, tension, adjustment or altitude compensation; snow, water, dirt or other foreign substance ingestion/contamination; improper maintenance; modified components; use of aftermarket or unapproved components, accessories, or attachments; use of unapproved software or calibration; unauthorized repairs; or repairs made after the warranty period expires or by an unauthorized repair center.

This warranty excludes damages or failures caused by abuse, accident, fire, or any other cause other than a defect in materials or workmanship and provides no coverage for consumable components, general wear items, or any parts exposed to friction surfaces, stresses, environmental conditions and/or contamination for which they were not designed or not intended, including but not limited to the following items:

- Wheels and tires
 - Suspension components
 - Brake components
 - Seat components
 - Clutches and components
 - Steering components
 - Batteries
 - Light bulbs/Sealed beam lamps
 - Filters
 - Lubricants
 - Bushings
 - Finished and unfinished surfaces
 - Carburetor/Throttle body components
 - Engine components
 - Drive belts
 - Hydraulic components and fluids
 - Circuit breakers/Fuses
 - Electronic components
 - Spark plugs
 - Sealants
 - Coolants
 - Bearings
-

LUBRICANTS AND FLUIDS

1. Mixing oil brands or using non-recommended oil may cause engine damage. We recommend the use of POLARIS engine oil.
2. Damage or failure resulting from the use of non-recommended lubricants or fluids is not covered by this warranty.

This warranty provides no coverage for personal loss or expense, including mileage, transportation costs, hotels, meals, shipping or handling fees, product pick-up or delivery, replacement rentals, loss of product use, loss of profits, or loss of vacation or personal time.

THE EXCLUSIVE REMEDY FOR BREACH OF THIS WARRANTY SHALL BE, AT EGIMOTORS' OPTION, REPAIR OR REPLACEMENT OF ANY DEFECTIVE MATERIALS, COMPONENTS, OR PRODUCTS. THE REMEDIES SET FORTH IN THIS WARRANTY ARE THE ONLY REMEDIES AVAILABLE TO ANY PERSON FOR BREACH OF THIS WARRANTY. EGIMOTORS SHALL HAVE NO LIABILITY TO ANY PERSON FOR INCIDENTAL, CONSEQUENTIAL OR SPECIAL DAMAGES OF ANY DESCRIPTION, WHETHER ARISING OUT OF EXPRESS OR IMPLIED WARRANTY OR ANY OTHER CONTRACT, NEGLIGENCE, OR OTHER TORT OR OTHERWISE. THIS EXCLUSION OF CONSEQUENTIAL, INCIDENTAL, AND SPECIAL DAMAGES IS INDEPENDENT FROM AND SHALL SURVIVE ANY FINDING THAT THE EXCLUSIVE REMEDY FAILED OF ITS ESSENTIAL PURPOSE.

THE IMPLIED WARRANTY OF FITNESS FOR A PARTICULAR PURPOSE IS EXCLUDED FROM THIS LIMITED WARRANTY. ALL OTHER IMPLIED WARRANTIES (INCLUDING BUT NOT LIMITED TO THE IMPLIED WARRANTY OF MERCHANTABILITY) ARE LIMITED IN DURATION TO THE ABOVE ONE YEAR WARRANTY PERIOD. EGIMOTORS DISCLAIMS ALL EXPRESS WARRANTIES NOT STATED IN THIS WARRANTY. SOME STATES DO NOT PERMIT THE EXCLUSION OR LIMITATION OF INCIDENTAL OR CONSEQUENTIAL DAMAGES OR ALLOW LIMITATIONS ON THE DURATION OF IMPLIED WARRANTIES, SO THE ABOVE LIMITATIONS MAY NOT APPLY TO YOU IF INCONSISTENT WITH CONTROLLING STATE LAW.

WARRANTY

HOW TO OBTAIN WARRANTY SERVICE

If your vehicle requires warranty service, you must take it to a EGIMOTORS Servicing Dealer. When requesting warranty service you must present your copy of the Warranty Registration Form to the dealer. (THE COST OF TRANSPORTATION TO AND FROM THE DEALER IS YOUR RESPONSIBILITY.) EGIMOTORS suggests that you use your original selling dealer; however, you may use any EGIMOTORS Servicing Dealer to perform warranty service.

IN THE COUNTRY WHERE YOUR PRODUCT WAS PURCHASED:

Warranty or Service Bulletin repairs must be done by an authorized EGIMOTORS dealer, or other qualified person. If you move or are traveling within the country where your product was purchased, Warranty and Service Bulletin repairs may be requested from any authorized EGIMOTORS dealer, or other qualified person, that sells the same line as your product.

OUTSIDE THE COUNTRY WHERE YOUR PRODUCT WAS PURCHASED:

If you are traveling temporarily outside the country where your product was purchased, you should take your product to an authorized EGIMOTORS dealer, or other qualified person. You must show the dealer photo identification from the country of the selling dealer's authorized location as proof of residence. Upon residence verification, the servicing dealer will be authorized to perform the warranty repair.

IF YOU MOVE:

If you move to another country, be sure to contact EGIMOTORS Customer Assistance and the customs department of the destination country before you move. Product importation rules vary considerably from country to country. You may be required to present documentation of your move to EGIMOTORS in order to continue your warranty coverage. You may also be required to obtain documentation from EGIMOTORS in order to register your product in your new country. You should warranty register your product at a local EGIMOTORS dealer in your new country immediately after you move to continue your warranty coverage and to ensure that you receive information and notices regarding your product.

IF YOU PURCHASE FROM A PRIVATE PARTY:

If you purchase a EGIMOTORS product from a private party, to be kept and used outside of the country in which the product was originally purchased, all warranty coverage will be denied. You must nonetheless register your product under your name and address with a local EGIMOTORS dealer in your country to ensure that you receive safety information and notices regarding your product.

EXPORTED PRODUCTS

EXCEPT WHERE SPECIFICALLY REQUIRED BY LAW, THERE IS NO WARRANTY OR SERVICE BULLETIN COVERAGE ON THIS PRODUCT IF IT IS SOLD OUTSIDE THE COUNTRY OF THE SELLING DEALER'S AUTHORIZED LOCATION. This policy does not apply to products that have received authorization for export from EGIMOTORS. Dealers may not give authorization for export. You should consult an authorized dealer to determine this product's warranty or service coverage if you have any questions. This policy does not apply to products registered to government officials or military personnel on assignment outside the country of the selling dealer's authorized location. This policy does not apply to Safety Bulletins.

NOTICE

If your product is registered outside of the country where it was purchased and you have not followed the procedure set above, your product will no longer be eligible for warranty or service bulletin coverage of any kind, other than safety recalls. Products registered to government officials or military personnel on assignment outside of the country where the product was purchased will continue to be covered by the Limited Warranty.

Please work with your dealer to resolve any warranty issues. Dealership contacts can be found via this website, if needed:

Should your dealer require any additional assistance, they will contact the appropriate person at EGIMOTORS.

This warranty gives you specific legal rights, and you may also have other rights which vary from state to state or in different countries. If any of the above terms are void because of federal, state, local law, all other warranty terms will remain in effect.

For questions reach EGIMOTORS on www.Egimotors.com

Tractor Certificate of Pre-Delivery

Year _____ Model _____

VIN _____

Engine Serial Number _____

Key Number _____ Km / Hours _____

Registration Plate Number _____

ASSEMBLY / SERVICE / INSPECTION

- - SEALED BATTERY – Apply dielectric grease to terminal bolts and install cable. Check Voltage and charge if below 12.8 Volts.
- - BATTERY VOLTAGE – Misuse and record the battery voltage after 30 minutes after charger has been removed _____ DCV
- - TIRE PRESSURE – Verify Pressure if set to Specification
- - WHEEL NUT – Torque to specification
- - HANDLEBAR CLAMPS - Torque bolts to specification
- - MASTER CYLINDER – Torque bolts to specification
- - FRONT TOE ALIGNMENT – Verify proper toe setting
- - BALL JOINT – Inspect bolts and/or cotter pin
- - STEERING POST – Inspect cotter pin
- - TIE ROD – Inspect jam nuts and cotter pin
- - TRANSMISSION – Add oil if needed
- - GREASE FITTING – Check and Grease all the Fitting if needed
- - ENGINE OIL – Check level of oil, add if needed
- - BRAKE FLUID – Check level of fluid, add if needed in brake master cylinder(s)
- - ENGINE COOLANT – Inspect coolant in recovery bottle. Add if needed.
- - PARK BRAKE – Verify proper operation
- - INTAKE AIRBOX – Inspect hose connection and clamps. Inspect filter condition.
- - LIGHTS – Verify operation of all lights
- - FUEL – Check level of fuel and add if needed
- - WIRE HARNESS / HOSE/ LINES – Inspect wire, hoses, and line from kinks, pinching and sign of abrasion.
- - UNIT INQUIRY – Check in the system and complete applicable Service Bulletins Recalls or factory direct modification(s)
- - COSMETIC INSPECTION – Inspect the quadricycle for damage and proper fit and finish.

DEALERSHIP NAME _____ # _____

ASSEMBLED BY _____

DATE _____ / _____ / _____

SIGNATURE

STAMP

Tractor Certificate of Pre-Delivery

Year _____ Model _____

VIN _____

Engine Serial Number _____

Key Number _____ Km / Hours _____

Registration Plate Number _____

TEST RIDE

- - ENGINE – Starting acceleration and smoothness.
- - IDLE SPEED – Verify when cold and hot the engine idle properly.
- - TROTTLER – With engine idling and transmission in Neutral, swing the handlebar through entire travel range and verify proper and smooth operation.
- - ETC - Verify proper operation and throttle free play.
- - AUXILIARY SHUT OFF SWITCH - Verify proper operation.
- - BRAKES - Verify proper operation. Torque bolts to specification
- - DRIVELINE – Verify smooth operation
- - CLUTCH / TRANSMISSION – Verify proper shifting and transmission engagement/ indicator lights must correspond with gears.
- - AWD ADC – Verify proper operation.
- - REVERSE SPEED LIMITER – Verify operation and override control.
- - INSTRUMENTATION – Verify operational reading.
- - WHINCH (If equipped) – Verify proper operation.
- - SUSPENSION / STEERING – Verify adjustment, stability and operation.
- - ENGINE COOLANT Inspect coolant in recovery bottle between Min and Max after test ride, add if necessary.
- - DIAGNOSTIC SYSTEM – Run Engine up to full operating temperature. Use digital Wrench to generate and submit a "Service Report" recommended Process.
- - LEAKAGE – After completing "Diagnostic System "check for leakage and verify proper connection of oil / exhaust / fuel / Coolant / Brake fluid fitting, inspect hoses for sign and abrasion.
- - CLEAN – Wash and clean the quadricycle before delivery.

TEST RIDDEN BY _____

DATE _____ / _____ / _____

SIGNATURE

STAMP

Tractor Certificate of Pre-Delivery

Year _____ Model _____

VIN _____

Engine Serial Number _____

Key Number _____ Km / Hours _____

Registration Plate Number _____

DELIVERY TO CUSTOMER

- - WARRANTY REGISTRATION FORM – Completed and signed.
- - OWNERS MANUAL – Emphasize the importance of reading for customer Safety and Servicing of Quadricycle/ Explain periodic maintenance responsibilities.
- - WARRANTY POLICY – Explanation / Limit / Requirements.
- - KEYS - Record Key Number.
- - Controls – Show location and function.
- - BELT LIFE – Discuss proper operation procedure operating and proper use of High and Low Gear Range.
- - BREAK IN PROCEDURE – Review as outline in Owner's Manual.
- - STORAGE / FUELING / TRANSPORTATION – Review as outline in the owner's manual.
- - TOOL KIT – Show location.
- - Safety Video – Review with Customer.
- - SAFETY FEATURES – Review all safety features of quadricycle operation for new operation.
- - DRIVING PROCEDURE – Review Operator driving procedure outlined in the Owner's Manual.
- - SVIA TRAINING FACT SHEET – Review with customer.
- - SAFETY TRAINING COURSE SVIA – I have instructed the owner on the authorized SVIA Safety training online course.
- - PRE-DELIVERY CERTIFICATION – I certify that pre-delivery inspection and service have been perform on this vehicle in accordance with the instructions issued by Egimotors.

DEALERSHIP NAME _____ # _____

DELIVERED BY _____

DATE _____ / _____ / _____

SIGNATURE

STAMP

Tractor Certificate of Pre-Delivery

Year _____ Model _____

VIN _____

Engine Serial Number _____

Key Number _____ Km / Hours _____

Registration Plate Number _____

CUSTOMER ACCEPTANCE

- - I have reviewed the Egimotors warranty Policy / Policies
- - I have inspected the Quadricycle and it meets my satisfaction.
- - I understand the importance of following the Owner's Manual and instructions.
- - I understand the importance of using all safety features.

Review with customer.

- - I understand the importance of all operation following the operator driving procedures in the Owner's Manual.
- - I have been instructed on the authorized online SVIA training course by my Dealer _____

(Name of dealership and person who inform the Customer)

CUSTOMER NAME _____

CUSTOMER SIGNATURE

DATE _____ / _____ / _____

Egimotors

Via Filippo da Desio 49/51
20832 Desio (MB) ITALY
info@polarisitalia.com

For more informations
visit www.Egimotors.it

