

*Egimotors*

**2024**

**OWNER'S MANUAL**

**TRACTOR**

**RZR PRO XP 4**

**Owner's manual part Number - OM24TRZRPROXP4**

Read this manual carefully. It contains important safety information. This is an adult Quadricycle only.  
Operation is prohibited for those under 18 years of age.

 **WARNING**

This Owner Manual refers to EGIMOTORS TRACTORS  
(To be filled in by your Dealer)

This Owner's Manual must remain inside you Tractor  
(Legal requirement)  
A digital/printable copy is available on [www.egimotors.it](http://www.egimotors.it)

Year \_\_\_\_\_

Model Type \_\_\_\_\_

Code number (spare parts use only) \_\_\_\_\_

VIN Number \_\_\_\_\_

Engine Serial Number \_\_\_\_\_

Personal PIN Security Code: \_\_\_\_\_

Registration Plate Number \_\_\_\_\_

Thank you for purchasing an Egimotors Tractor, and welcome to our world-wide family of enthusiasts.

We have done This manual to inform you on how to use and maintain the best condition of operation for your Tractor.

If after reading this manual, you still have some questions please do not hesitate to contact your dealer that will be available to help you.

Be sure to visit us online at [www.Egimotors.it](http://www.Egimotors.it) for the latest news and for product and Safety information.

We believe we sets a standard of excellence for all utility and Tractor manufactured in the world today.

Many years of experience have gone into the engineering, design, and development of your Tractor, making it the finest machine we've ever produced.

For safe and enjoyable operation of your Tractor, be sure to follow the instructions and recommendations in this owner's manual.

Your manual contains instructions for the maintenance of the Tractor and information about repairs.

Service Manual are available from Dealers, only them can perform major repair and install accessory.

Your dealer knows your Tractor better than anyone and is interested in your total satisfaction, he can perform your service needs during and after the warranty period.

For the most up-to-date owner's manual visit:

<http://egimotors.it/libretto-uso-manutenzione/>



Read and understand this Owner's Manual is extremely important for your safety and for all the operators, so please take your time to read all the pages and be sure that is someone else will use the Tractor before will take this manual and read and understand all, this will give you the best knowledge and skills on how to ride in security.

All the information contained within this publication is based on the latest product information at the time of publication.

Due to constant improvement in the design and quality of product components, some minor discrepancies may result between the actual unit and the information presented in this publication.

Descriptions and or procedure in this publication are intended for reference use only. No Liability can be accepted for omission or inaccuracies. Any reprinting or reuse of the depictions and or procedures contained within this publication are intended for reference use only. The original instruction is in English.

Other languages are provided as translation of the original Instruction see the Egimotors website for more details and procedure.

## SAFETY SYMBOLS AND SIGNAL WORDS

---

The following signal words and symbols appear throughout this manual and on your Tractor. Your safety is involved when these words and symbols are used. Become familiar with their meanings before reading the manual.

### DANGER

DANGER indicates a hazardous situation which, if not avoided, WILL result in death or serious injury.

### WARNING

WARNING indicates a hazardous situation which, if not avoided, COULD result in death or serious injury.

### CAUTION



CAUTION indicates a hazardous situation which, if not avoided, COULD result in minor to moderate injury.

### NOTICE

NOTICE provides key information by clarifying instructions.

### IMPORTANT

IMPORTANT provides key reminders during disassembly, assembly, and inspection of components.

ICON	DESCRIPTION
	The Prohibition Safety Sign indicates an action NOT to take in order to avoid a hazard.
	The Mandatory Action Sign indicates an action that NEEDS to be taken to avoid a hazard.

**Introduction** .....

**Safety**.....

**Features and Controls** .....

**Operation** .....

**Emission Control Systems** .....

**Maintenance** .....

**Specifications**.....

**Products**.....

**Troubleshooting**.....

**Warranty**.....

**Maintenance Log**.....

**Certificate of Pre-Delivery** .....

# INTRODUCTION BEFORE YOU RIDE

### WARNING

Failure to heed the warnings and safety precautions contained in this manual can result in severe injury or death. Your EGIMOTORS vehicle is not a toy and can be hazardous to operate. This vehicle handles differently than cars, trucks or other off-road vehicles. A collision or rollover can occur quickly, even during routine maneuvers like turning, or driving on hills or over obstacles, if you fail to take proper precautions.

- Read this owner's manual that came with your vehicle.
- Understand all safety warnings, precautions and operating procedures before operating the vehicle. Keep this manual with the vehicle.
- Never operate this vehicle without proper instruction. Take an authorized training course. See the Safety Training section for more information.
- This vehicle is an **ADULT VEHICLE ONLY**. You **MUST** be at least age 18 and have a valid driver's license to operate this vehicle.
- Always use the cab nets (or doors) while riding in this vehicle. Always keep hands, feet and all other body parts inside the vehicle at all times.
- Always wear a helmet, eye protection, gloves, long-sleeve shirt, long pants and over-the-ankle boots.
- Never operate this vehicle under the influence of drugs or alcohol, as these conditions impair judgement and reduce the operator's ability to react.
- Complete a training course before operating this vehicle. Never allow a guest to operate this vehicle until the guest has completed a training course.
- Never permit a guest to operate this vehicle unless the guest has reviewed the owner's manual and all safety labels and has completed a safety training course



---

## SAFETY

### OWNER REQUIREMENTS

**Improper use, maintenance, or modification of this Tractor can lead to serious injury or death.**

**Require proper use of your Tractor.** Do not allow anyone to operate your Tractor or ride as a passenger unless they are properly instructed and you are sure they are willing to ride responsibly. To prevent unauthorized use, always remove the ignition key when the Tractor is not in use.



**Any modifications or installation of non-EGIMOTORS-approved accessories could increase the risk of injury.** While you may find aftermarket products similar in design and quality to EGIMOTORS accessories, recognize that some aftermarket accessories or modifications are not suitable because of potential safety hazards to you or others. It is never appropriate to install any additional seating.

Check with the manufacturer to determine any potential effect of a modification or accessory on the safe use of your Tractor. You are responsible for injuries related to modifications to the Tractor. Modifications or accessories may:

- Damage machine components - especially modifications that increase speed or power.
- Make the Tractor less stable at higher speeds.
- Add weight, reducing the amount of cargo and total weight you can carry, and raise the Tractor's center of gravity.
- Overload the Tractor's electrical system capacity. Blowing a fuse may cause a loss of lights or engine power.
- Reduce the effectiveness of occupant protection systems, including the seatbelts and the Rollover Protective Structure (ROPS).
- Make it illegal to own or operate your Tractor. EGIMOTORS-authorized spark arresters, mufflers, and emissions control components are mandatory for ownership or operation in many areas.
- Void your warranty.

**The Tractor ROPS, when used with the seat belts and doors, provides a structure to help protect occupants.** The structure will not protect occupants in all rollovers or accidents.

### DRIVER AND PASSENGER QUALIFICATIONS

**Make sure operators are 18 or older with a valid driver's license.** Just because a teenager has a license does not mean that they will make good judgments about driving and avoid risk taking.

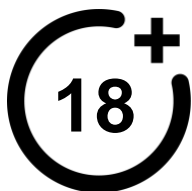

EGIMOTORS recommends that you supervise younger drivers. Set rules and put limits on how, when, and where they are allowed to use this Tractor. For example, young drivers may need to have an adult in the Tractor with them and not be allowed to drive with their friends in the Tractor.

**Make sure all riders fit the Tractor.** Be sure that the driver and all passengers are able to:

- sit with their backs against their seat,
- adjust the seat belt to fit properly,
- have both feet flat on the floor, and
- have both hands on the steering wheel or on a passenger hand hold.

**Do not allow children who need child safety seats or booster seats to ride in the Tractor.** The Tractor is not designed to restrain automotive child safety seats.

**You are responsible for your passengers.** Be sure passengers are seated properly, belted, holding the passenger hand hold, and ready to brace. Unrestrained riders can fall out or be thrown around and from a moving Tractor.

**Every person must be properly seated and belted in their own seat.** Two people should never be belted into a single seat belt. People belted together can crash into one another in a collision and be seriously injured. Never carry passengers in the cargo bed as they could be thrown against or out of the Tractor or come into contact with moving parts.

**Do not let people drive or ride after using alcohol or drugs.**

## PREPARE TRACTOR FOR THE RIDE

**Before starting off, always perform the Pre-Ride Inspection.** Failure to inspect and verify that the Tractor is in safe operating condition increases the risk of an accident, which can lead to serious injury or death.



ITEM	REMARK
Brake Fluid	Ensure proper level and condition
Front and rear suspension	Inspect, lubricate if necessary
Steering	Ensure free operation
Tires	Inspect condition and pressure
Wheels/Lug Nuts	Inspect, ensure fastener tightness
Fuel and oil	Ensure proper levels and condition
Coolant	Ensure proper level and condition
Indicator lights/switches	Ensure proper operation
Air Filter	Inspect, replace as needed
Engine intake pre-filter	Inspect, clean
PVT intake pre-filter	Inspect, clean
Headlights	Check operation
Brake lights/taillights	Check operation
Seat Latches	Push down on both seat backs to ensure the latches are secure

## SAFETY

---

ITEM	REMARK
Seat Belts	Check length of belt for damage, check latches for proper operation
Exhaust	Inspect spark arrester and clean if needed.
Tractor Debris	Remove grass, leaves, and other flammable material or debris, especially near the exhaust system.
Passenger Hand Hold	Always adjust the hand hold to a comfortable position for your passenger before operating. Make sure the clasps are fully locked after making adjustments.
Lock adjustable steering wheel	Do not adjust the steering wheel while the Tractor is moving.

**Improper tire maintenance** can lead to loss of control and an accident, which could result in serious injury or death. To reduce your risk of injury:

- Maintain EGIMOTORS recommended tire pressure. Check pressure before operating. Even if your Tractor has only been driven a short distance, the tire pressure readings can become higher.
- Make sure tire pressures match the specifications listed in the table below.
- Only use the size and type of tires specified for this Tractor.
- Do not operate your Tractor with worn or damaged tires.
- Always follow your tire manufacturer's instructions for maintenance.

### PREPARE YOURSELF, PASSENGERS, AND CARGO FOR THE RIDE

**Wear an approved helmet.** Riding in this Tractor without wearing an approved helmet increases the risk of serious injury. For example, a helmet reduces your risk of injury from head strikes with the Tractor or other objects even if there is no crash.

Approved helmets in Europe, bear the ECE 22.05 label. The ECE mark consists of a circle surrounding the letter E, followed by the distinguishing number of the country which has granted approval. The approval number and serial number will also be displayed on the label.



**Use shatterproof goggles or a shatterproof helmet face shield.** Such protective eyewear may reduce the risk of foreign material getting in your eyes and help prevent loss of vision.

EGIMOTORS recommends wearing approved Personal Protective Equipment (PPE) that have markings indicating they are designed to standards such as:

- CE



**Additional protective clothing and gear** that may be appropriate for your riding conditions includes:

- Always wear shoes when operating. Consider wearing sturdy over-the-ankle boots suitable for the terrain you will be riding in.
- Full-finger gloves can protect against wind, sun, cold, and objects. Choose gloves that fit snugly and allow fingers to move freely and grip on the steering wheel or hand holds.
- Consider long sleeves and long pants to help protect arms and legs.
- Long-term exposure to wind and engine noise can cause permanent hearing loss. Properly worn hearing protective devices such as earplugs can help prevent hearing loss. Check local laws or the rules of the riding area you are in before wearing hearing protection to make sure its use is permitted.

**Always stay completely inside the Tractor and hold the steering wheel or hand holds.** Body parts outside of the Tractor can be struck by passing objects or crushed during a rollover. Do not put any part of your body outside of the Tractor for any reason. Do not hold onto the ROPS frame or put any part of your body on the door.

Riding in this Tractor without closed and latched cab doors increases the risk of serious injury or death in the event of an accident or rollover. Always make sure all cab doors are closed and latched while riding in this Tractor.

**Be sure riders pay attention and plan ahead.** If you think or feel the Tractor may tip or roll, reduce your risk of injury:

- Keep a firm grip on the steering wheel or hand holds and brace yourself.
- Do not put any part of your body outside of the Tractor for any reason.

**This Tractor is not designed to carry unrestrained pets.** An unrestrained pet can be thrown about and injure riders, even during normal operation. When transporting pets, use a pet crate suitable for off-road use that is secured to the Tractor.

**Fuels such as gasoline can be extremely flammable.** To reduce the risk of serious injury or death, never carry fuel or other flammable liquids on this Tractor. Rollovers, crashes, rough riding, or changes in elevation or temperature may lead to fuel spilling or vapor release from portable containers. Hot Tractor parts can cause fires, even after the engine has been turned off.

**Never exceed Tractor weight capacities.** Overloading the Tractor or carrying cargo improperly will cause changes in stability and handling, which could cause loss of control or an accident. See the Specifications chapter for weight capacities.

**Secure cargo in the cargo box as far forward, centered and as low as possible.** When cargo cannot be positioned and secured in this way, operate with extra caution. Unsecured cargo can strike and injure riders, affect Tractor handling, and result in loss of control.

**The weight of riders and cargo changes Tractor braking, handling, and stability.** To avoid loss of control, turn gradually, operate at slower speeds, and avoid rougher or steeper terrain.

## DRIVING GUIDELINES

**Drive Responsibly.** This Tractor has higher ground clearance and other features to handle rugged terrain. It can be overturned in situations where some other Tractors may not. Abrupt maneuvers or aggressive driving, even on flat, open areas, can cause loss of control, rollovers, severe injury or death. To avoid loss of control and rollovers:



- Avoid abrupt maneuvers, sideways sliding, skidding, or fishtailing, and never do donuts.
- Slow down before entering turn.
- Avoid hard acceleration when turning, even from a stop.

### High speed off-road operation

Driving off-road Tractors to test the limits of your skills or abilities can be very dangerous to you, passengers, and bystanders. Basic skills for driving a car, ATV, or other off-road Tractors do not equip drivers to safely attempt high speed off-road operation. Develop your skill gradually through training, practice, and experience with the various driving modes of this Tractor and the terrain in which you are operating. Always do a low-speed reconnaissance run (pre run) to become aware of anything you may encounter.

High speed off-road operation can lead to loss of control, crashes, or hard landings that can seriously injure occupants (even without rolling the Tractor or damaging it).

If you plan on using the Tractor for high speed, off-road competition, additional safety equipment may be necessary. Check the rules that apply to your competition.

### **Do not go over jumps — going airborne can lead to serious injury or death.**

Going airborne can cause loss of control, rollovers, or crashing into the ground and may damage the Tractor. Even without crashing, landings can be hard enough to cause any Tractor suspension to fully compress (e.g., bottom out). Serious injuries, including spinal injuries, can occur even if riders are properly harnessed, wearing helmets and the Tractor is not damaged and remains upright.

You may encounter slopes, "jumps", or other terrain features that could send the Tractor airborne, depending on your speed. These may be defectively designed, poorly maintained, or not suitable for this Tractor. Slow down, use extra care, and avoid going airborne. Never take this Tractor over jumps.



Watching someone else go over a jump or go airborne does not mean you can safely do so. Egimotors cannot determine whether any jump you may encounter is appropriate for this Tractor. Any jump, even a small one, could be poorly maintained, designed, or not suitable for this Tractor and may cause serious injury or death.



### **Plan for hills, rough terrain, ruts, and other changes in traction and terrain.**

Proceed slowly and with extra care on unfamiliar terrain. Avoid paved surfaces. Sudden changes in terrain such as holes, depressions, banks, softer or harder ground, or other irregularities may cause loss of control or rollover. Give yourself time to react to rocks, bumps, or holes that may be hard to see. Operating in deep snow or tall grass may make it harder to see obstacles.

If you cannot go around an obstacle, such as a fallen tree or a ditch, stop the Tractor in a safe place. Get out to inspect the area thoroughly. Look from both your approach side and exit side. If you are reasonably confident you can continue safely, choose the path that will allow you to go straight over the obstacle to minimize the Tractor tipping sideways. Go only fast enough to maintain your momentum, but still give yourself plenty of time to react to changes in conditions. If there is any question about your ability to maneuver safely over the obstacle, you should turn around if the ground is flat and you have the room, or back up until you find a less difficult path.

Abrupt application of the accelerator pedal can cause the tires to lose traction, reducing control of the Tractor and increasing the possibility of an accident, especially while on sloped terrain or while crossing obstacles such as rocks or logs.

### **Operating on Public Roads**

If your Quadricycle is registered with a license plate as for public use road, anyway, operating this Quadricycle on mayor public streets could result in a collision with another vehicle.

Never operate this Quadricycle on highway see your locals law concerning the category of your Quadricycle and where you can use it.

Quadricycles are allowed only on secondary road with a limited speed, respect all the rules.

## SAFETY

---

**Improperly operating on hills can cause loss of control, rollover, or accident**, which can lead to serious injury or death. Use extra care when operating on hills. Plan for rough terrain, ruts, and other changes in traction and terrain.

### **Driving up hills**

Check the terrain before ascending a hill and make sure it is not too slippery or loose. Engage all-wheel drive for hills. Drive straight uphill, keeping speed and throttle steady. Avoid steep hills which can cause the Tractor to overturn.

### **Recovering from stalling on a hill**

If the Tractor loses forward speed, apply the brakes gradually and stop. Do not attempt to turn the Tractor around. Instead, shift to reverse and allow the Tractor to slowly roll straight downhill. Apply light brake pressure to control speed.

### **Overtopping a hill**

Slow down when you reach the crest of a hill. Never blindly go over the crest of a hill or a drop off at high speed. An obstacle, a sharp drop, or another Tractor or person could be on the other side of the hill.

### **Driving down hills**

Check the terrain before descending a hill and make sure it is not too slippery or loose. Engage all-wheel drive and proceed slowly, applying the brakes lightly. Never descend a hill with the transmission in neutral or if the engine is turned off.

### **Avoid side hilling (riding across slopes)**

If unavoidable, proceed slowly and with extra caution. Avoid obstacles and changes in terrain that could cause the Tractor to tip or slide. If it feels like the Tractor begins to tip or slide, immediately turn downhill.

### **Riding near wooded areas or brush**

Use extra caution when operating near trees, particularly when operating on narrow trails. Tree branches or brush can be driven into the cab striking or stabbing occupants.



**Riding in snow**

Always keep the brake and accelerator pedals free of snow and ice. Apply the brakes frequently to prevent ice or snow accumulation on the brake pads which can reduce brake performance.

**Riding on ice**

Never operate the Tractor on a frozen body of water unless you have verified that the ice can support the weight of the Tractor. Severe injury or death can result if the Tractor falls through the ice.

**Riding in water / Falling into water**

Operating through deep or fast-flowing water can cause loss of traction, loss of control, overturning, or being swept away in water. You can be seriously injured or killed from entrapment and drowning. Never operate the Tractor in fast-flowing water or in water that exceeds the floor level of the Tractor. Avoid sharp drop-offs and large rocks. Choose a path that provides an entrance and exit point with gradual inclines. Wet brakes may have reduced stopping ability. After leaving water, test the brakes. Apply them lightly several times while driving slowly. The friction will help dry out the pads.

**Riding on sand dunes**

Use extra caution when operating on or near dunes. Be alert for changes in terrain. Never blindly go over the crest of a hill or a drop-off at high speed. An obstacle, a sharp drop, or another Tractor or a person could be on the other side of the hill.

**Riding in low-visibility conditions**

Use extra caution and drive slowly in conditions of reduced visibility such as fog, rain, and darkness.

**Plan ahead to avoid the need for evasive maneuvers, such as swerving.**

Hitting an obstacle — including wildlife — you are not ready for can be dangerous. Choosing to swerve instead can be even more dangerous because it can lead to loss of control, rollover, or collisions.

When operating in areas with possibility of wildlife appearing in your path, plan ahead to avoid swerving for animals if doing so could result in collisions or rollovers. Go slowly or avoid driving during seasons or times of day when animals such as deer are more likely to cross your path without warning.

## SAFETY

---

### **Avoid Collisions With Other Tractors**

When following another Tractor or operating in the same area as others, keep a safe distance to avoid collisions. Allow extra space when sight distances are limited by dust, snow, curves, hills, or other conditions. Plan ahead to avoid having to swerve or leave the trail to avoid a collision.

On trails, be prepared to make space for other Tractors to pass. If you need to stop on a trail, move your Tractor to the edge of the path to allow others to pass safely.

### **Correct a skid by turning the steering wheel in the direction of the skid.**

Never apply the brakes during a skid.

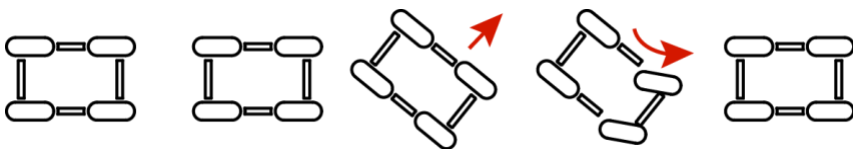

If the Tractor begins to slide downhill or you feel it may tip, turn downhill immediately and stop. Maneuver slowly and carefully until you can drive straight downhill.

### **Do not continue driving if your Tractor may be damaged or if you were in a crash or rollover.**

Operating the Tractor while damaged or after a crash or rollover can cause loss of control, rollover, or accident, which can lead to serious injury or death. If you cannot safely transport the Tractor on your own, contact a recovery and towing service.

After any crash, rollover, or other accident, have a EGIMOTORS dealer inspect the Tractor for possible damage, including seat belts, ROPS, brakes, suspension, and steering systems.

Be prepared in case your Tractor becomes damaged or disabled, especially in remote areas. Consider in advance how to get help and stay safe until it arrives whenever you ride.

### **The Tractor does not have a tow hitch and is not designed to tow another Tractor for any distance.**

Towing can alter Tractor handling and may cause loss of control.

---

**There is a recovery tow loop at the front and back of the Tractor to attach a winch or strap.**

Use these loops to recover this Tractor if it is stuck, to pull it onto a tow truck, trailer, or to use this Tractor to recover another Tractor. These loops are for emergency recovery only and are not for towing Tractors to another location.

Improper recovery may lead to loss of control or Tractor damage. Only attach straps to specified locations. Do not attach to any other point on the Tractor. Only recover a Tractor of equal or lesser size and weight. When recovering a disabled Tractor, place the disabled Tractor's transmission in neutral. Do not move a disabled RZR faster than 10 mph (18 km/h).

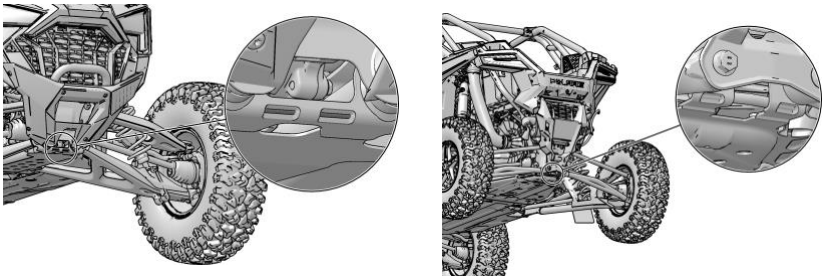
**Operating, Idling, Or Parking Near Combustible Materials**

Engine, exhaust, and other Tractor components can be very hot during and after use. Do not idle or park the Tractor over anything that could contact the exhaust system and catch on fire, such as tall grass, weeds, brush, leaves, debris, or other tall ground cover. Do not let mud, grass, or other debris accumulate on the engine or exhaust system. Inspect and remove as needed.

**Tractor rollaway can cause serious injury or death.** This Tractor can roll whenever the gear selector is not in the PARK (P) position. Always shift to PARK (P) when stopping the engine or leaving the Tractor. When leaving the Tractor on an incline is unavoidable, use extra care. If leaving the Tractor unattended, block the rear wheels on the downhill side and keep children, pets, and others away from the gear selector.

**Before shifting into reverse, use extra care to make sure the area is clear of people or obstacles.** When it's safe to proceed, back slowly.

## SAFETY

---

**After operation, inspect the Tractor for damage and debris** to make sure the Tractor can be safely stored and operated again. Some things to inspect include:

- Debris that could catch fire, such as mud/grass near the engine or exhaust system
- Damage to the suspension, steering, or any other part of the Tractor
- Tire condition, such as tread and sidewall damage
- Shock absorber assembly condition

Be sure to have any issues checked and problems fixed before operating again.

**All engine exhaust contains carbon monoxide**, a deadly gas. Breathing carbon monoxide can cause headaches, dizziness, drowsiness, nausea, confusion, and eventually death. Carbon monoxide is a colorless, odorless, tasteless gas which may be present even if you do not see or smell any engine exhaust. Deadly levels of carbon monoxide can collect rapidly, and you can quickly be overcome and unable to save yourself. Also, deadly levels of carbon monoxide can linger for hours or days in enclosed or poorly ventilated areas. If you experience any symptoms of carbon monoxide poisoning, leave the area immediately, get fresh air, and **SEEK MEDICAL TREATMENT**.

- Do not run engine indoors. Even if you try to ventilate engine exhaust with fans or open windows and doors, carbon monoxide can rapidly reach dangerous levels.
- Do not run engine in poorly ventilated or partially enclosed areas such as barns, garages, or carports. If you start a Tractor in one of these, drive it out and close the door as soon as possible. If you drive it into one of these, turn it off as soon as possible.
- Do not run engine outdoors where engine exhaust can be drawn into a building through openings such as windows and doors.

---

## TOWING A RZR

Towing this Tractor is not recommended. Always transport the Tractor on a trailer or flatbed with all four wheels off the ground. See the Transporting the Tractor section for details.

If towing a disabled Tractor is unavoidable, place the disabled Tractor's transmission in neutral. Tow the shortest distance possible. Do not operate faster than 10 mph (18 km/h).

## TOWING LOADS



Towing improperly can alter Tractor handling and may cause loss of control or brake instability.

# SAFETY

---

## TRAILERING SAFETY

The weight distribution of the cargo loaded onto the trailer is important and will have an impact on how the Tractor handles on the road. Ensure the weight of the cargo is distributed properly and the trailer is not rear, front, or side heavy.

Improperly trailering or attempting to tow this Tractor can result in serious injury or death. Improper transportation can also cause Tractor damage, which may involve parts flying off and creating road hazards for other motorists.

### **Face the Tractor forward.**

When using a non-enclosed trailer, face the Tractor forward or remove the roof.

Always use a spotter if you are uncomfortable loading the Tractor on your own. A wheel chock or marker can also be used as an indication of how close you will park the Tractor from the front of the trailer.

### **Ensure everything in the Tractor is secure.**

Walk around the Tractor and make sure:

- Doors are latched
- Front hood and storage compartments are locked
- Rear seat backs are latched
- Cargo is secured or removed
- Tractor is in PARK (P)

### **Use designated tie down points.**

This Tractor is equipped with four tie down points for transport. Route straps so that they cannot contact any part of the Tractor and become worn or loose during transport. Do not use winch to secure Tractor to trailer.

### **Towing this Tractor is not recommended.**

Transport this Tractor on a trailer or flatbed with all four wheels off the ground. If it is unavoidable to tow this Tractor when it is disabled, place this Tractor's transmission in NEUTRAL and tow the shortest distance possible. Do not tow this Tractor faster than 10 mph (18 km/h).

### **Use suitable tie downs.**

Securing devices, such as tie down straps, are manufactured to support a maximum strength or load limit that can be applied during normal service. This is known as the Working Load Limit (WLL). Each tie-down strap must have a WLL exceeding the minimum WLL.



## TRANSPORTING THE TRACTOR

Follow these procedures when transporting the Tractor.

1. Place the transmission in PARK. Stop the engine.
2. Slowly release the brake pedal and make sure the transmission is in PARK before exiting the Tractor
3. Remove the key to prevent loss during transporting.
4. Secure the fuel cap and seats. Ensure that the seats are attached correctly and are not loose.

### WARNING

Cargo and other loose Tractor parts may fly off while transporting this Tractor. Secure or remove all cargo, and inspect the unit for loose parts prior to transport.

If transporting the Tractor in a non-enclosed trailer, then the Tractor must FACE FORWARD, or roof must be removed.

Failure to comply may allow airflow, vibration, or other factors to separate the roof from the Tractor and cause an accident, resulting in serious personal injury or death.

5. Always tie the frame of the EGIMOTORS Tractor to the transporting unit securely with suitable straps or rope. Do not attach tie straps to the front control arm bolt pockets.

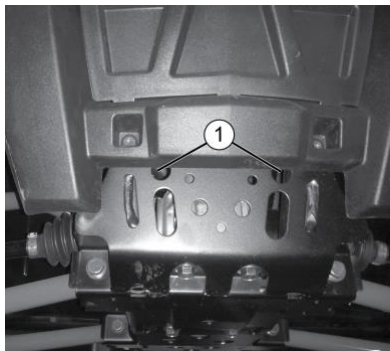

(1) Two Front Tie-Down Points



(2) Two Rear Tie-Down Points  
(or tow loop)

# SAFETY

---

## SAFETY LABELS AND LOCATIONS

### OVERVIEW

Warning labels have been placed on the Tractor for your protection. Read and follow the instructions of the labels on the Tractor carefully. If any of the labels depicted in this manual differ from the labels on your Tractor, always read and follow the instructions of the labels on the Tractor

Never remove any labels from your Tractor. If a label becomes illegible or comes off, contact your EGIMOTORS dealer for a replacement. Replacement safety labels are provided at no charge.

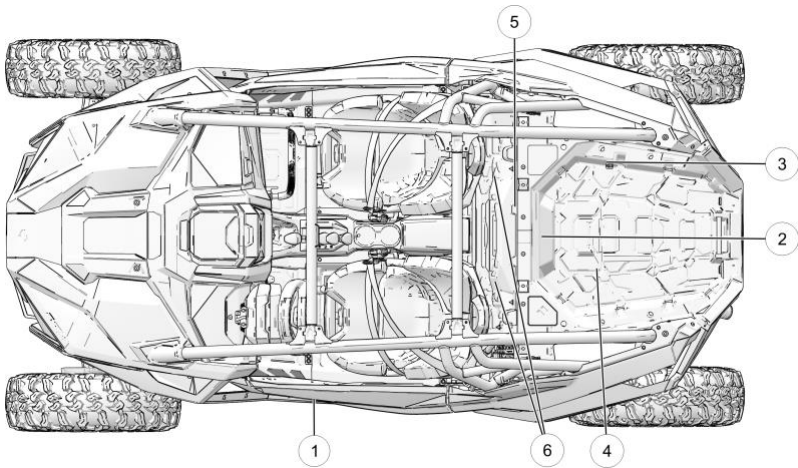

(1) Driver Information Warning

(4) Belt Debris Warning (On Clutch Cover)

(2) Tire Pressure

(5) Air Box (On Air Box)

(3) Fuel Transport Warning

(6) Rear Seat (Pro XP 4 Only)

---

## DRIVER INFORMATION WARNING — PRO XP 4

### WARNING

FOLLOW ALL INSTRUCTIONS AND WARNINGS.

Improper Tractor use can result in SEVERE INJURY or DEATH.

#### Be Prepared

- Fasten seat belts.
- Wear an approved helmet and protective gear.
- **ALWAYS** use cab nets and/or doors.
- Each rider must be able to sit with back against seat, feet flat on the floor, and hands on steering wheel or hand holds. Stay completely inside the Tractor.

#### Drive Responsibly

Rollovers have caused severe injuries and death, even on flat, open areas.

#### Avoid loss of control and rollovers:

- Avoid abrupt maneuvers, sideways sliding, skidding or fishtailing, and never do donuts.
- Slow down before entering a turn.
- Avoid hard acceleration when turning, even from a stop.
- Plan for hills, rough terrain, ruts and other changes in traction and terrain.
- Avoid paved surfaces.
- Avoid side hilling (riding across slopes).

#### Require Proper Use of Your Tractor

Do your part to prevent injuries:

- Do not allow careless or reckless driving.
- Make sure operators are 18 or older with a valid driver's license.
- Do not let people drive or ride after using alcohol or drugs.
- Do not allow operation on public roads (unless designated for off-highway Tractor access) - collisions with cars and trucks can occur.
- Do not exceed seating capacity: 3 passenger.

#### Be Sure Riders Pay Attention and Plan Ahead

If you think or feel the Tractor may tip or roll, reduce your risk of injury:

- Keep a firm grip on the steering wheel or hand holds and brace yourself.
- Do not put any part of your body outside of the Tractor for any reason.

## SAFETY

---

### LOAD / PASSENGER / TIRE PRESSURE WARNING

The Load / Passenger / Tire Pressure Warning  $\eta$  is located at the rear of the Tractor in the cargo box.

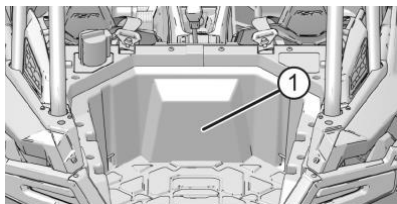

- Never carry passengers in cargo box.
- Passengers can be thrown off. This can cause serious injury or death.

**IMPROPER TIRE PRESSURE OR OVERLOADING CAN CAUSE LOSS OF CONTROL RESULTING IN SERIOUS INJURY OR DEATH.**

- Reduce speed and allow greater distance for braking when carrying cargo.
- Overloading or carrying tall, off-center, or unsecured loads will increase your risk of losing control. Loads should be centered and carried as low as possible in box.
- For stability on rough or hilly terrain, reduce speed and cargo.

## FUEL TRANSPORT WARNING

### WARNING

NEVER carry fuel or other flammable liquids on this Tractor.

Failure to follow this instruction could lead to serious burn injuries or death.



## BELT DEBRIS WARNING

The Belt Debris warning e is located on the clutch cover.

Improper service or maintenance of this PVT system can result in Tractor damage, SEVERE INJURY or DEATH.

Always look for and remove debris inside and around clutch and vent system when replacing belt.

Read owner's manual or see authorized Egimotors dealer.

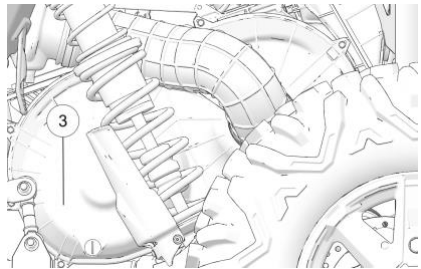

## SAFETY

---

### AIR BOX CAUTION

#### CAUTION:

Use a Egimotors approved air filter. The use of a non-Egimotors approved air filter may cause engine damage. Before installing filter, ensure there is no dirt or debris in the clean side of the intake tube. The air filter must be properly seated before the lid is reinstalled. Please reference your owner's manual for additional information regarding air filter service.

#### (1) Air Box Caution

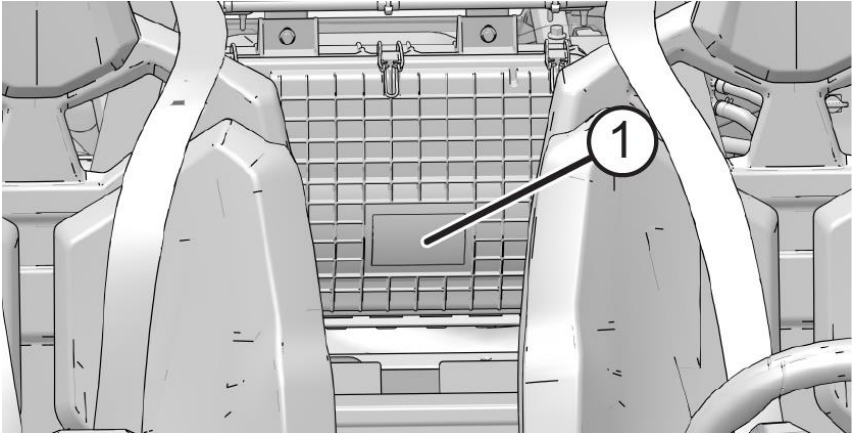

### REAR SEAT WARNING — PRO XP 4

#### WARNING

Do not ride in rear cabin area when seat back or seat base is not installed in riding position.

# FEATURES AND CONTROLS

## NEAR-FIELD COMMUNICATION (NFC)

Some Egimotors Tractors come equipped with a near-field communication (NFC) chip. The NFC chip is embedded in the Egimotors emblem located at the front of the Tractor and seamlessly connects you to a digital platform of Tractor information and tools. See your dealer for more information.

### IMPORTANT

Not all devices are equipped with an NFC reader. Additionally, some devices require third party applications to access NFC content. For questions regarding the NFC reader on your device, refer to the device's user manual.

On models equipped with NFC, place your smartphone directly over the Egimotors emblem to do the following:

- View Tractor-specific information
- Access your Egimotors Garage
- Download and view the owner's manual
- View accessory instructions
- Watch how-to videos
- Access warranty information
- Check for service notifications



## RIDE COMMAND WITH NFC

Additional NFC features are available when using the Ride Command mobile app. To access these features, do the following:

1. Download the Ride Command mobile app from the Apple App Store® or Google Play® store.
2. Create or log in to an existing account.
3. From the Ride Command mobile app home screen, select **Add Tractor**.
4. On the Tractor, tap the NFC-enabled badge with the phone to scan the Tractor.
5. Confirm information, name your Tractor, and tap add to garage.

## SYSTEM REQUIREMENTS

Refer to device manufacturer's instructions to verify NFC read capability, and/or NFC-capable add-ons.

### COMPONENT LOCATIONS

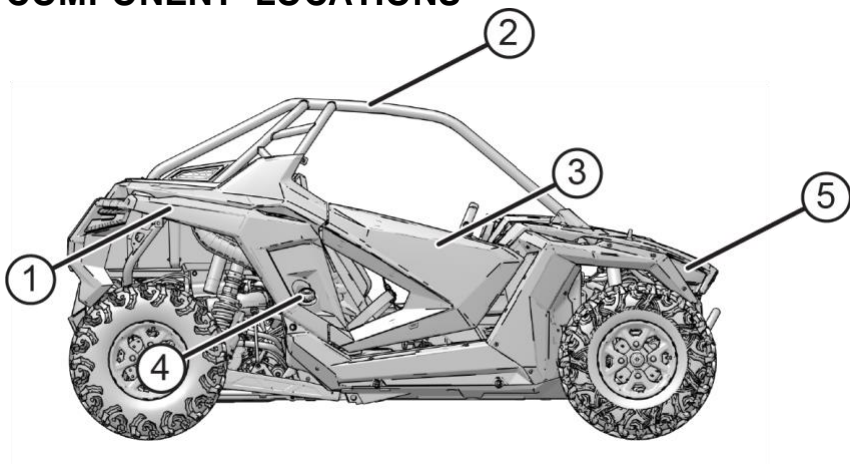

- (1) Cargo Box
- (2) ROPS Frame
- (3) Cab Door
- (4) Fuel Tank Cap
- (5) Radiators



## STANDARD STEERING WHEEL (IF EQUIPPED)

The steering wheel can be tilted upward or downward for rider preference. Lift and hold the steering wheel adjustment lever (1) while moving the steering wheel upward or downward. Release the lever when the steering wheel is at the desired position.

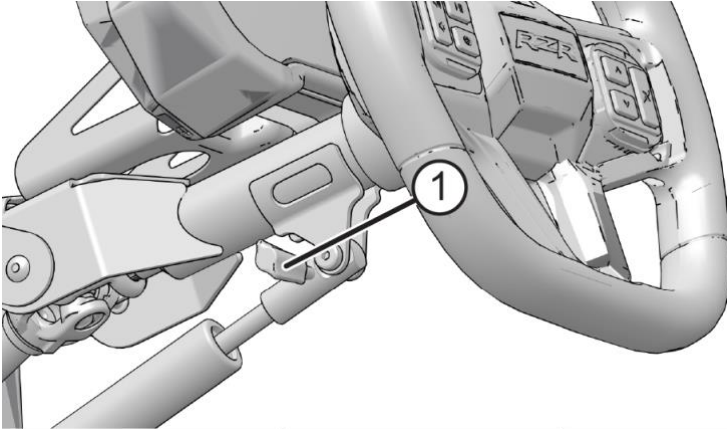

## TELESCOPE STEERING WHEEL (IF EQUIPPED)

The telescoping steering wheel can be adjusted by pressing the release lever (1) downward. Once released, the steering wheel can be tilted up/down and telescoped in/out freely. When desired position is found, hold the steering wheel in place with one hand and pull the release lever back up with the other. The release lever will catch into place when it is locked.

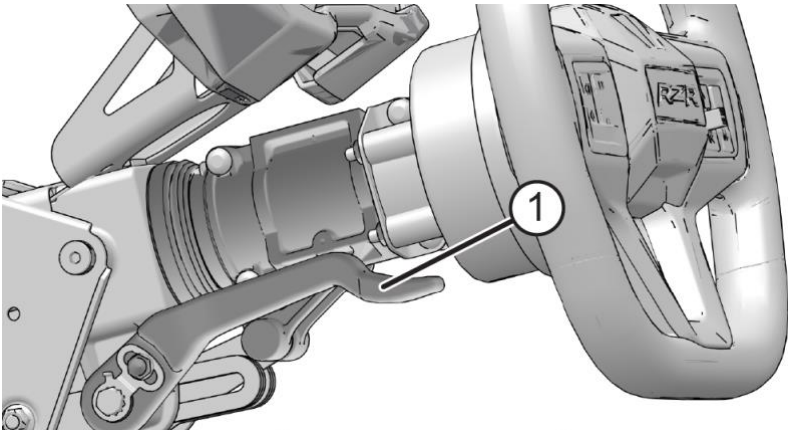

### SWITCHES

#### IGNITION SWITCH

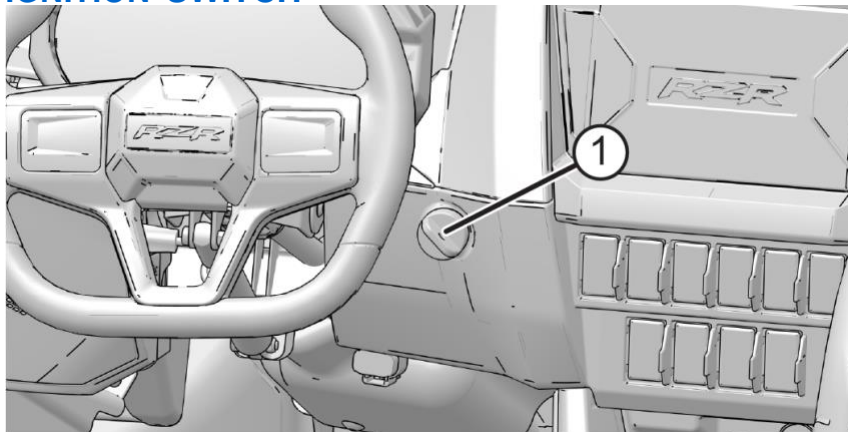

The ignition switch (1) is a four-position, key-operated switch. Use the ignition switch to start the engine. See the Starting the Engine section for starting procedures.

POSITION	FUNCTION
OFF	The engine is off. Electrical circuits are off, except accessory 12V.
ACCESSORY	The engine is off. Powers the display, terminal block, and front/rear accent lights. Check engine and power steering warning indicators will appear on the display in this mode but will turn off when the Tractor is started if no issues are present.
ON	Electrical circuits are on. Electrical equipment can be used.
START	The Tractor must be in PARK or NEUTRAL before the engine can start. To start the Tractor, press the brake pedal, turn the key to the start position, and then release. The engine will turn over for about 5 seconds or until started.

The key can be removed from the switch when it is in the OFF position.

### HEADLIGHT SWITCH

The ignition switch key must be in the ON/RUN position to operate the headlights. The headlight switch is a toggle and has three positions:

UP – High Beam

CENTER – Low Beam

DOWN – Headlights Off

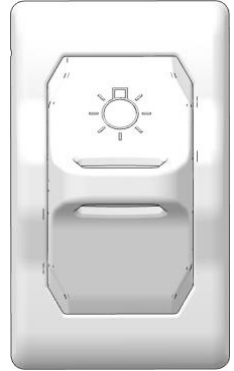

### DRIVELINE MODE (AWD) SWITCH

The ignition switch key must be in the ON/RUN position to operate the Driveline Mode system. The Driveline Mode switch is a toggle and has two positions:

UP – All Wheel Drive (AWD)

CENTER – Two Wheel Drive (2WD)

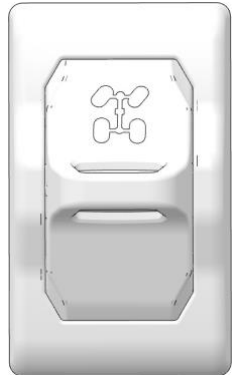

## FEATURES AND CONTROLS

### AUXILIARY OUTLETS

#### WARNING

To avoid electric shock, do not touch power outlets with wet hands or insert any object that the power outlet is not designed to receive. Close the lid when not in use.

#### NOTICE

The front console accessory outlet is always active. The accessory outlet in the armrest storage bin is only active when the ignition switch is set to ON.

The Tractor is equipped with two 12-volt accessory outlets. One is in the front portion of the center console, in front of the gear selector. The other is in the armrest storage bin. Use the outlets to power an auxiliary light or other optional accessories. The front accessory outlet can be used for battery charging. See for details.



### TRACTOR BATTERY CHARGE PORT

This Tractor is equipped with a Tractor battery charge port located on the dash. This allows the operator to charge the Tractor battery without needing to access the battery under the driver's seat. See the Battery Maintenance and Charging section for details.



### **ELECTRONIC POWER STEERING (EPS)**

Electronic power steering engages when the ignition key is turned to the ON position. EPS remains engaged whether the Tractor is moving or idle.

The EPS warning indicator briefly illuminates when the key is turned to the ON position. See the Indicator Lamps section for details.

If the engine is off but the ignition switch remains in the ON position, the EPS will shut down after 5 minutes of engine inactivity. The EPS warning indicator will illuminate to indicate the EPS has shut down.

If the EPS warning indicator remains on after turning the ignition switch to OFF and then starting the engine, the EPS system is inoperative. See your EGIMOTORS dealer, or another qualified person, as soon as possible for repair. Continued operation could result in permanent damage to the EPS unit and increased steering effort.

## FEATURES AND CONTROLS

### STEERING WHEEL CONTROLS

#### SUSPENSION CONTROLS (IF EQUIPPED)

If equipped, suspension controls can be found on the right-hand side of the steering wheel. There are 3 available suspension modes to select from: Firm, Sport, and Comfort.

The firmness of the suspension can be adjusted by pressing the UP button (more firm) or the DOWN button (less firm).

The momentary MAX FIRM button is on the right. When this button is pressed, the suspension will immediately switch to maximum firmness. The Tractor will maintain this setting if the button is continuously pressed. Once the button is released, maximum firmness will persist temporarily, and then revert back to the previous setting.

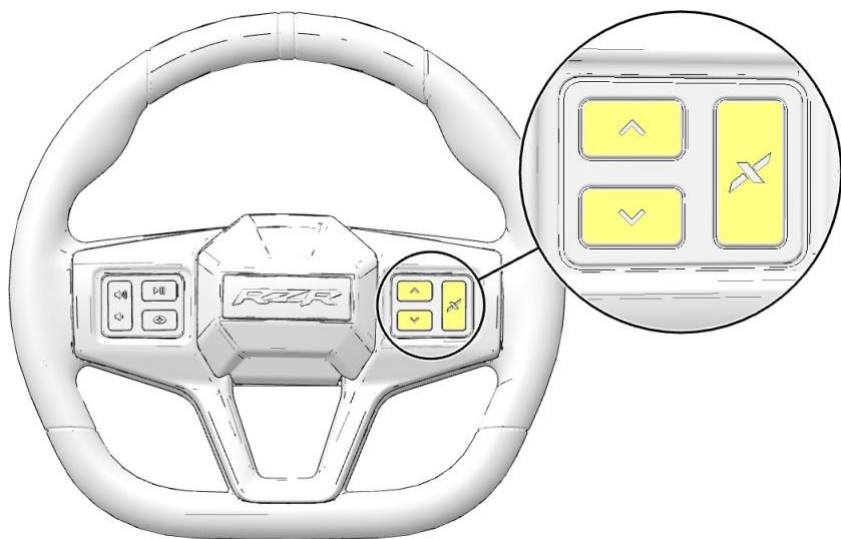

#### WARNING

The operator should use caution to select the appropriate suspension mode to match the current terrain conditions and driving style. Failure to select an appropriate suspension mode could lead to Tractor dynamic behaviors not matched to the terrain or driver's skill level.

#### NOTICE

The system will prevent mode transitions from a more firm operating mode to a more soft operating mode when a current active Tractor state is present (cornering, braking, accelerating, or airborne).

In **Firm Mode**, the compression damping reverts to a firm setting with suspension response optimized for harsh terrain. Recommended for terrain where suspension would be put under more stress.

In **Sport Mode**, some rider comfort is traded for responsiveness. Damping ramps up more aggressively as a function of Tractor speed. Recommended for spirited driving where additional suspension system performance with regard to cornering, braking, acceleration, side hilling, and airborne detection may be required.

In **Comfort mode**, the suspension control system is optimized for rider comfort, intervening in performance situations only where required. Recommended for less challenging terrain and more moderate operation.

### AUDIO CONTROLS (IF EQUIPPED)

If equipped, audio controls can be found on the left-hand side of the steering wheel.

Volume can be adjusted by pressing the bottom (lower volume) or the top (higher volume) of the button.

Audio can be paused or resumed by pressing the pause button.

Refer to the Ride Command manual for operating the third Egimotors button.

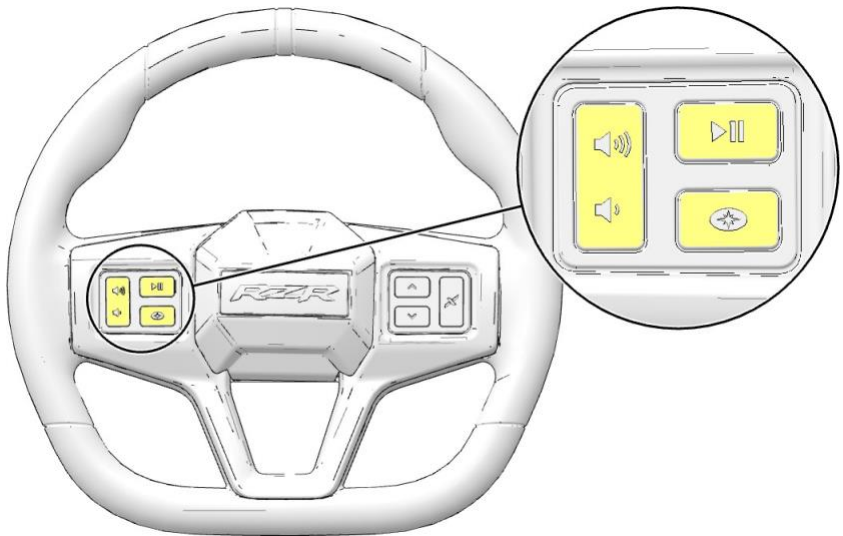

### SEATS



Prolonged sun exposure can cause excessive heating of the steering wheel and seats. Use caution when handling hot surfaces to avoid burns.

Before operating the Tractor, always push down on all seat backs to ensure the latches are secure.

### SEAT REMOVAL

To adjust the seat, do the following:

1. Pull up on the seat latch lever **q** located under the front edge of the seat.
2. Tilt the seat forward.
3. Lift the seat upward to remove it from the Tractor.

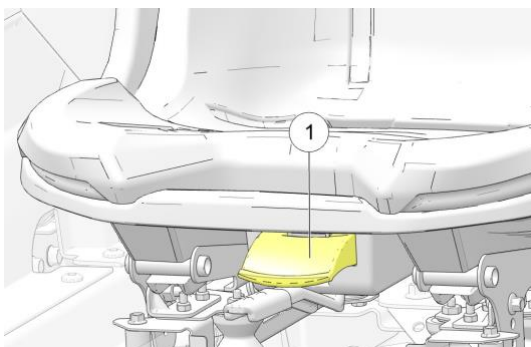

4. Reverse this procedure to reinstall the seat. Make sure the seat tabs at the front edge of the seat slide onto the seat retainer tubes.
5. Press down firmly at the rear of the seat to engage the rear latches.



## SEAT ADJUSTMENTS

### DRIVER'S SEAT ADJUSTMENT

On seats equipped with an adjustment lever (1) under the front edge of the seat, pull the lever to the left. Slide the seat forward or rearward to the desired position. Release the lever. The seat will lock into the new position.

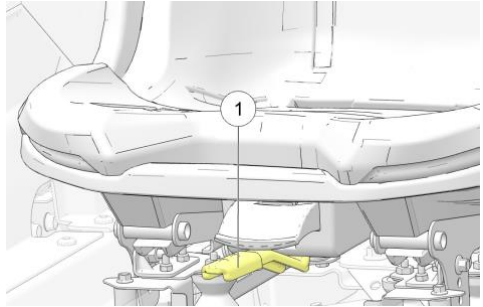

To adjust seat tilt, adjustment bolts can be removed and re-installed at a different tilt setting. The driver side has two adjustment bolts (2), one on each side, and has three tilt hole options. Re-install the bolts to specification when finished with adjustments.

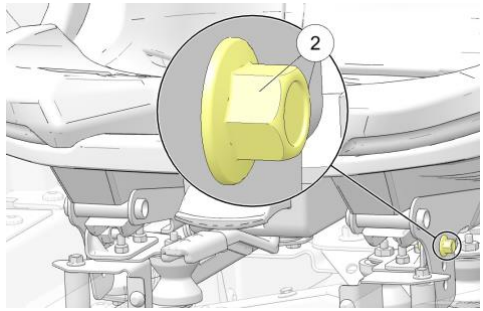

### TORQUE

Seat Adjustment Bolts:  
**(20 N·m)**

## FEATURES AND CONTROLS

### **PASSENGER SEAT ADJUSTMENT**

To adjust the passenger seat position, remove the seat and remove the four bolts (3) located on the two seat frame members. The seat frame members can be moved forward (or backward) to the desired position.

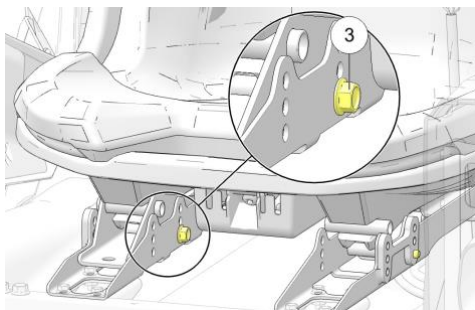

The passenger seat can also be tilted up/down (similar to the driver seat) using the three tilt hole options. Choosing which set of tilt holes to use is dependent on whether the seat position has been moved forward or backward. Re-install the bolts to (20 N·m) of torque when finished with adjustments.

#### TORQUE

Seat Adjustment Bolts:  
(20 N·m)

### **PASSENGER HAND HOLD**

Always adjust the hand hold to a comfortable position for your passenger before operating. Make sure the clasps 1 are fully locked after making adjustments.

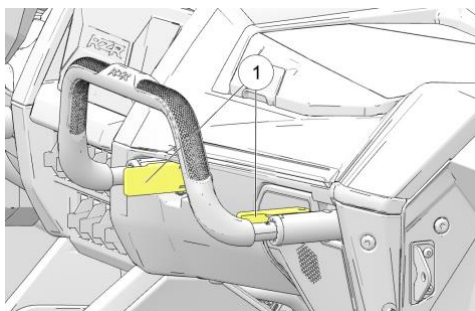

To adjust the passenger hand hold, do the following:

1. Unlock the two passenger hand hold clasps q.
2. Pull or Push the bar to desired position.
3. Lock both clasps back into place.

### FUEL RECOMMENDATIONS

- Use ONLY 91 octane (or higher) unleaded fuel (minimum pump octane number of 91 R+M/2)
- Do not use any fuel lower than 91 octane
- Do not use fuel containing more than 10% ethanol (including E85)

### FUEL LEVEL

The fuel tank filler cap (1) is located on the right side of the Tractor near the passenger seat.

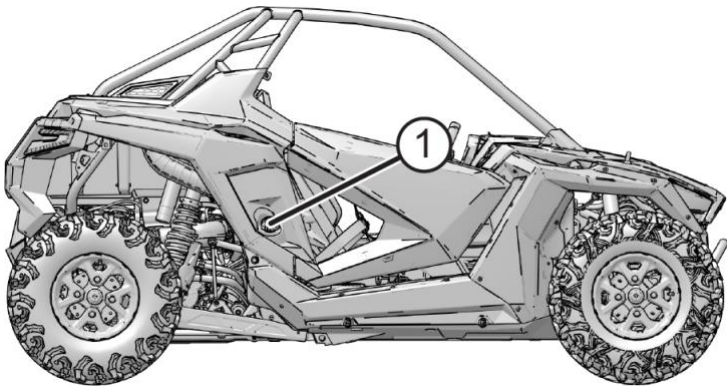

The fuel symbol and the last fuel bar on the MFD gauge will blink when the fuel level reaches 1/6th tank. There will be approximately (8 L) of fuel remaining. Refuel as soon as possible. *Do not allow the Tractor to run out of fuel.*

#### NOTICE

Damage to the fuel pump will occur if the Tractor is operated with an empty fuel tank. Do not allow the Tractor to run out of fuel. Always refuel when the level is low.

#### NOTICE

Operating with obstructed fuel systems will result in serious engine damage. Perform maintenance as recommended.

#### NOTICE

Prolonged exposure to petroleum-based products may damage paint. Always protect painted surfaces when handling fuel.

## FEATURES AND CONTROLS

---

### SEAT BELTS

This EGIMOTORS Tractor is equipped with seat belts for all riders. Always make sure the seat belts are secured for the operator and all passengers before riding. The driver's seat belt is equipped with a seat belt interlock. Tractor speed will be limited to 15 mph (24 km/h) if the seat belt is not secured.

#### 3-POINT SEAT BELT

To wear the 3-point seat belt properly, follow this procedure:

1. Pull the seat belt latch downward and across your chest toward the buckle at the inner edge of the seat. The belt should fit snugly across your hips and diagonally across your chest. Make sure the belt is not twisted.
2. Push the latch plate into the buckle until it clicks. Pull up on the strap to tighten.
3. Press the red release latch on the buckle to release the seat belt.

#### 6-POINT SEAT BELT



Be sure to follow the procedures below exactly as described. Improperly securing the seat belt can result in free movement during operation, which can lead to injury.

This Tractor is equipped with a Click-6 safety harness with built-in interlock. To wear the 6-point seat belt properly, follow this procedure:

1. Pull both the seat belt latch and buckle across your chest.
2. Push the latch plate into the buckle until it clicks.
3. Pull on the adjustment straps to tighten the straps on your hips and thighs.
4. To release the seat belt, press the red release latch on the buckle.

### SEAT BELT INSPECTION

Inspect all seat belts for proper operation before each use of the Tractor.

1. Pull each seat belt completely out and inspect the full length for any damage, including cuts, wear, fraying or stiffness. If any damage is found, or if the seat belt does not operate properly, have the seat belt system checked and/or replaced by a qualified technician.
2. To clean dirt or debris from the seat belts, sponge the straps with mild soap and water. Do not use bleach, dye or household detergents. Rinse the entire length of the belt webbing.

### CAB DOORS

This Tractor is equipped with cab doors. Riding in this Tractor without closed and latched cab doors increases the risk of serious injury or death in the event of an accident or rollover. Always make sure all cab doors are closed and latched when riding in this Tractor.

Always inspect doors and latches for wear and damage before each use of the Tractor.

Promptly replace any worn or damaged parts with new parts available from your authorized EGIMOTORS dealer or qualified person.

### SERVICE ACCESS PANELS

#### ENGINE ACCESS PANEL

The engine access panel is located behind the seats. Adjust or remove the seats, then remove the panel to reach serviceable engine components. Remove the panel by turning the close-off knobs (1) 1/4 turn.

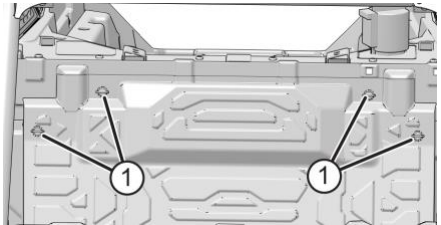

#### CARGO BOX ACCESS



The cargo box rests directly above heat-generating Tractor components. Be careful when removing the cargo box immediately following operation. It will likely be hot and could cause burns.

The entire cargo box layer can be lifted to access the engine oil fill cap and spark plugs by removing the four rear-most screws (2).

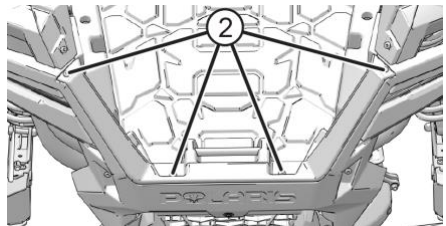

## FEATURES AND CONTROLS

### ROLLOVER PROTECTIVE STRUCTURE (ROPS)

The Rollover Protective Structure (ROPS) on this Tractor meets OSHA<sup>SM</sup> 29CFR 1928.53 rollover performance requirements. Always have your authorized EGIMOTORS dealer thoroughly inspect the ROPS if it ever becomes damaged in any way.

#### NOTE

Be mindful of the ROPS bars when boarding and exiting the Tractor.

(1) ROPS Label

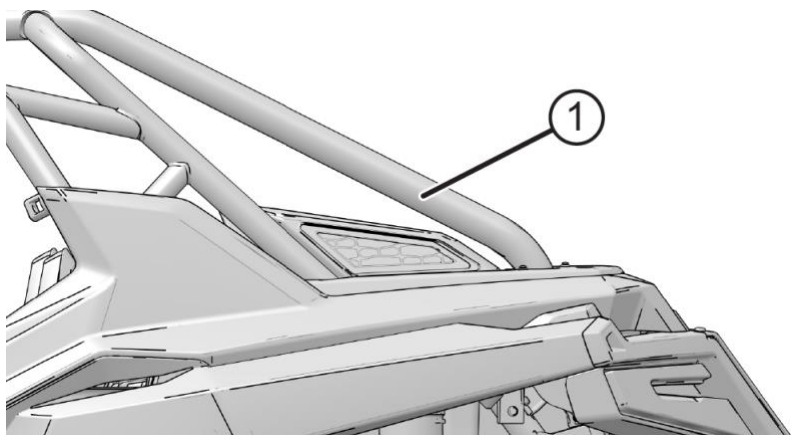

*No device can assure occupant protection in the event of a rollover. When used with seat belts and cab nets or doors, the ROPS helps prevent occupants from being ejected from the Tractor. Always follow all safe operating practices outlined in this manual to avoid Tractor rollover.*

#### WARNING

Tractor rollover could cause severe injury or death. Always avoid operating in a manner that could result in Tractor rollover.

### GEAR SELECTOR

The gear selector is located between the driver and passenger seat. To change gears, stop the Tractor and with the engine idling, move the lever to the desired gear. Do not attempt to shift gears with engine speed above idle or while the Tractor is moving.

- P: Park
- R: Reverse
- N: Neutral
- L: Low Gear
- H: High Gear

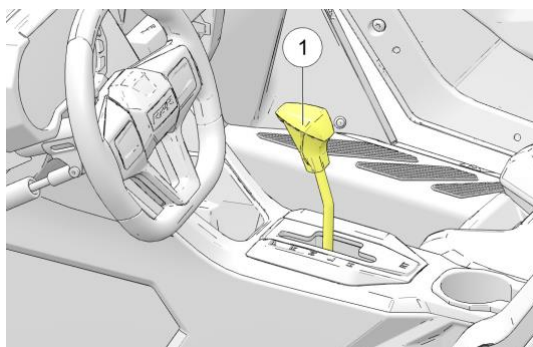

#### NOTICE

Maintaining shift linkage adjustment is important to assure proper transmission function. Your EGIMOTORS dealer can assist in resolving any shifting

#### NOTICE

Do not attempt to shift the transmission while the Tractor is moving or damage to the transmission could result. Always shift when the Tractor is stationary, and the engine is at idle.

### USING LOW RANGE

#### NOTICE

Using Low Gear during when conditions require it will prolong the life of your Tractor's drive belt.

Always shift into low gear for any of the following conditions:

- Operating in rough terrain or over obstacles
- Loading the Tractor onto a trailer
- When hauling or towing heavy cargo.
- When consistently operating at speeds less than (56 km/h) in hard-pulling terrain, such as mud, rocks, or sand/dune environments.

### BRAKE AND THROTTLE PEDALS

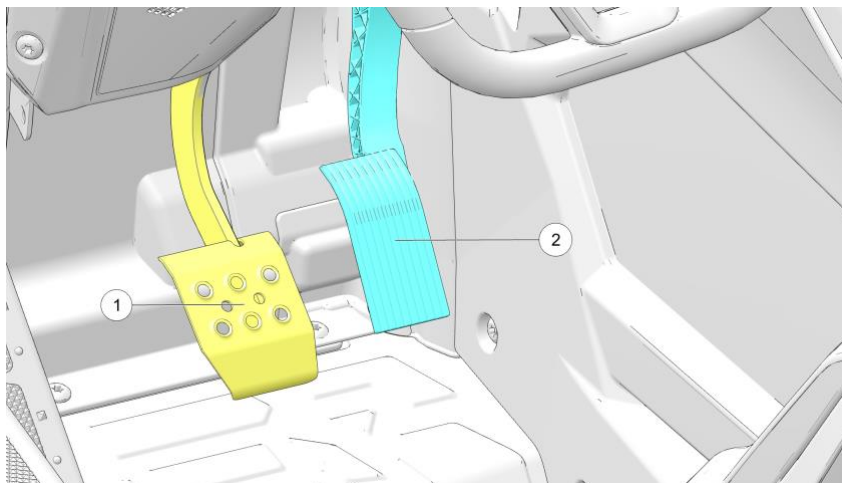

#### BRAKE PEDAL

Depress the brake pedal **q** to slow or stop the Tractor. The brakes must be applied in order to start the engine.

#### THROTTLE PEDAL

Push the throttle pedal **w** down to increase engine speed. Spring pressure returns the pedal to the rest position when released. Always check that the throttle pedal returns normally before starting the engine.

#### SECONDARY PEDAL



Your Tractor is equipped with a secondary Foot pedal in case of need and fail of the primary





### ALL WHEEL DRIVE (AWD) SYSTEM

The All Wheel Drive system is controlled by the AWD switch. Once the Tractor is in gear, the switch is set to one of two driveline modes.

ICON	DRIVELINE MODE	DESCRIPTION
	Two-Wheel Drive (2WD)	When the switch is set to 2WD the Tractor is in two-wheel drive at all times.
	All Wheel Drive (AWD)	<p>When the switch is set to AWD and the Tractor is in Drive or Reverse, the Tractor is in all wheel drive and the 4X4 indicator in the instrument cluster will be on</p> <p>When in AWD, the demand drive unit will automatically engage any time the rear wheels lose traction. When the rear wheels regain traction, the demand drive unit will automatically disengage.</p> <p>There is no limit to the speed or length of time the Tractor may remain in AWD.</p>

### ENGAGING AWD

The AWD switch may be turned on or off while the Tractor is moving. Initially, the Tractor's electronic system will not enable the AWD until the engine RPM is below 3100 and the Tractor speed is below 15 mph (24 km/h). Once enabled, the AWD remains enabled until the AWD switch is turned off. If the switch is turned off while the demand drive unit is moving, it will not disengage until the rear wheels regain traction.

Engage the AWD switch before getting into conditions where all-wheel drive may be needed. If the rear wheels are spinning, release the throttle before switching to AWD.

#### NOTICE

Switching to AWD while the rear wheels are spinning or slipping may cause severe drive shaft, prop shaft, and gearcase damage. Always switch to AWD while the rear wheels have traction or are at rest.

## FEATURES AND CONTROLS

### INSTRUMENT CLUSTER

#### NOTICE

High water pressure may damage components. Wash the Tractor by hand or with a garden hose using mild soap. Certain products, including insect repellents and chemicals, will damage the speedometer lens and other plastic surfaces. Do not use alcohol or cleaning products containing alcohol to clean the instrument cluster. Do not allow insect sprays to contact the lens. Immediately clean off any gasoline that splashes on the instrument cluster.



- |                     |                              |
|---------------------|------------------------------|
| (1) Speedometer     | (4) Mode Button              |
| (2) Tachometer      | (5) Toggle Buttons           |
| (3) Indicator Lamps | (6) Rider Information Center |

### SPEEDOMETER

The speedometer displays Tractor speed in either miles per hour (MPH) or kilometers per hour (km/h).

### TACHOMETER

The tachometer displays engine speed in revolutions per minute (RPM).

## MODE AND TOGGLE BUTTONS



Press and hold the MODE button  to enter or exit the settings menu. Press and release the MODE button to cycle through Area 1 modes and to select an item.

Press and release either toggle button  to cycle through the options menu or Area 2 modes. Press and hold either toggle button to reset an item. See page 60.







### TIP

With the ignition key off, pressing the MODE button or either toggle button will power up the Rider Information Center for 10 seconds to allow viewing of the odometer and the clock.



## INDICATOR LAMPS

INDICATOR	ICON	FUNCTION
Tractor Speed	<b>MPH</b>	When standard mode is selected, speed displays in miles per hour.
	<b>km/h</b>	When metric mode is selected, speed displays in kilometers per hour.
Check Engine		This indicator appears if a fault occurs. Do not operate the Tractor if this warning appears. Serious engine damage could result. Your authorized EGIMOTORS dealer can assist.
Chassis Warning		If a fault condition is detected, the light will remain on as long as the condition exists. Retrieve the error codes for diagnosis. This lamp is also known as an Amber Warning Lamp (AWL).
EPS Warning (if equipped)		This indicator illuminates briefly when the key is turned to the ON position. If the light remains on, the EPS system is inoperative. See your EGIMOTORS dealer, or other qualified person, as soon as possible for repair. Continued operation could result in permanent damage to the EPS unit and increased steering effort. For more information, see the Electronic Power Steering (EPS) section.

## FEATURES AND CONTROLS

INDICATOR	ICON	FUNCTION
Engine Hot		This lamp illuminates to indicate an overheated engine. If the indicator flashes, the overheating condition remains, and the system will automatically reduce engine power.
Check Battery		This warning usually indicates that the Tractor is operating at an RPM too low to keep the battery charged. It may also occur when the engine is at idle and high electrical load (lights, cooling fan, accessories) is applied. Drive at a higher RPM or recharge the battery to clear the warning.
PASS (PIN Activated Security System, if equipped)		The security indicator lamp illuminates when the security system is enabled.
Low Fuel		The low fuel indicator lamp illuminates when fuel level in the fuel tank is low.
Neutral		The neutral indicator lamp illuminates when the transmission is in neutral and the ignition key is in the ON position.
Helmet/Seat Belt		This lamp is a reminder to the operator to ensure all riders are wearing helmets and seat belts before operating. The driver's seat belt is equipped with a seat belt interlock. Tractor speed will be limited to 15 MPH (24 km/h) if the seat belt is not secured.

## FEATURES AND CONTROLS

INDICATOR	ICON	FUNCTION
High Beam		This lamp illuminates when the headlamp switch is set to high beam.
Park Brake (if equipped)		Lamp illuminates when the Park Brake is applied (if equipped).

## FEATURES AND CONTROLS

### RIDER INFORMATION CENTER

The rider information center is located in the instrument cluster. All segments will light up for one second at start-up.

If the instrument cluster fails to illuminate, a battery over-voltage may have occurred and the instrument cluster may have shut off to protect the electronic components within. If this occurs, your EGIMOTORS dealer can provide proper diagnosis.

The information center is set to display standard units of measurement and a 12-hour clock at the factory. To change to metric and/or a 24-hour clock, see the Clock section.

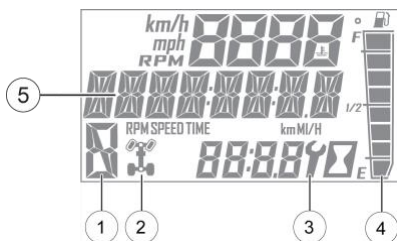

1	Gear Indicator	This indicator displays gear shifter position H = High Gear L = Low Gear N = Neutral R = Reverse Gear P = Park - = Gear Signal Error (or shifter between gears)
2	AWD Indicator	This indicator shows whether 2X4 or AWD is active when the Tractor is in gear.
3	Service Indicator	A flashing wrench symbol alerts the operator that the preset service interval has been reached. Your EGIMOTORS dealer can provide scheduled maintenance. See page 63 for resetting instructions.
4	Fuel Gauge	The segments of the fuel gauge show the level of fuel in the fuel tank. When the last segment clears, a low fuel warning is activated. The outline of the fuel display will flash. Refuel immediately.
5	Speed Limitation (if equipped)	This Tractor may be equipped with a maximum speed limitation function. This would be displayed on the screen as "LIM" followed by the speed. "LIM 30" for example.

## MODE INFORMATION DISPLAYS

The rider information center contains three areas that display mode information.

q Display Area 1

w Display Area 2

e Display Area 3

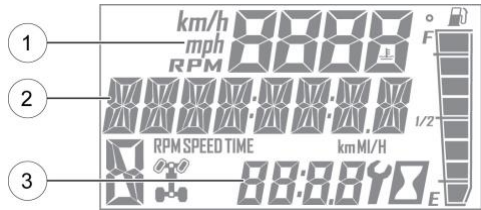

DISPLAY AREA 1	DESCRIPTION
Engine Temperature	Temperature of engine coolant
Tractor Speed	Speed of Tractor
Tachometer	Engine speed (RPM)

DISPLAY AREA 2	DESCRIPTION
Odometer	Records and displays the distance traveled by the Tractor.
Trip Meters (T1/T2)	Records the distance traveled by the Tractor if reset before each trip. To reset, see page 62.
Voltmeter	Displays the Tractor's electric output.
Engine Hours	Total hours of engine operation since manufacture.
Service Hours	A flashing wrench symbol indicates that the preset service interval has been reached. To reset, see page 63.
Engine Temperature	Temperature of engine coolant

DISPLAY AREA 3	DESCRIPTION
Clock	The clock displays time in a 12-hour or 24-hour format. To reset, see page 61.

## FEATURES AND CONTROLS

---

### ACCESSING MENUS AND OPTIONS

#### **GAUGE SETTINGS MENU**

Press and release the MODE button to cycle through the Area 1 modes until the desired default mode displays. See the Mode Information Displays section for details.

Press and hold the MODE button to enter the settings menu.

*The OPTIONS screen will display for a few seconds.*

1. Press and release either toggle button to cycle to the desired option.
2. Press MODE to select the option.
3. Press either toggle button to cycle to the desired setting.
4. Press MODE to save and exit to the settings menu.
5. Press and hold the MODE button to exit the settings menu.

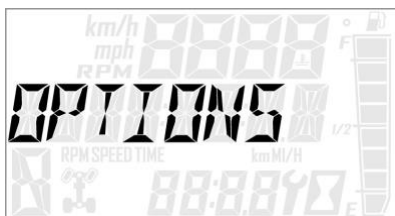

#### **BACKLIGHT COLOR**

The information center backlight can be set to either blue or red.

1. Press and hold the MODE button to enter the settings menu.
2. Press either toggle button to cycle to the "BL COLOR" option. Press MODE to select.
3. Press either toggle button to cycle to the desired setting.
4. Press MODE to save and exit to the settings menu,





### **BACKLIGHT BRIGHTNESS**

The information center backlight brightness can be adjusted.

1. Press and hold the MODE button to enter the settings menu.
2. Press either toggle button to cycle to the "BL LEVEL" option. Press MODE to select.
3. Press "UP" button to increase brightness. Press "DOWN" button to decrease brightness.
4. Press MODE to select and exit to the settings menu.



### **CLOCK**

The clock must be reset any time the battery has been disconnected or discharged.

1. Press and hold the MODE button to enter the settings menu.
2. Press either toggle button to cycle to the "CLOCK" option. Press MODE to select.
3. Press either toggle button to cycle to the desired setting (12H or 24H). Press MODE to select.
4. Press either toggle button to change each segment of the clock. Press MODE to accept a change and advance to the next segment.



## FEATURES AND CONTROLS

---

### DISPLAY UNITS (STANDARD/METRIC)



1. Press and hold the MODE button to enter the settings menu.
2. Press either toggle button to cycle to the desired "UNITS" option (distance, temperature or volume). Press MODE to select.
3. Press either toggle button to cycle to the desired setting.
4. Press MODE to save and exit to the settings menu.

### TRIP METER

Use a trip meter to track the distance traveled during a specific trip or period of time. Reset the meter to zero before traveling.

1. Press either toggle button to cycle to the desired trip meter option (T1 or T2).
2. Press and hold either toggle button until the meter resets to zero.



### **PROGRAMMABLE SERVICE INTERVAL**

The service interval counter is programmed to 25 hours at the factory. As hours of engine operation increase, the counter decreases. The wrench icon will flash for about 10 seconds when the counter reaches zero (0), and each time the key is turned on thereafter, until the counter is reset.

When this feature is enabled, it provides a convenient reminder to perform routine maintenance. Refer to the Periodic Maintenance Chart for recommended service intervals.

Use the following procedure to reset or change the service interval.

1. Press and hold the MODE button to enter the settings menu.
2. Press either toggle button to cycle to the "Service Hours" option. Press MODE to select.
3. Press MODE to reset the existing value and exit, or press either toggle button to change the value. Press MODE to save and exit to the settings menu.



## FEATURES AND CONTROLS

---

### **PIN ACTIVATED SECURITY SYSTEM (P.A.S.S.) (IF EQUIPPED) — INSTRUMENT CLUSTER**

For Tractors with the Ride Command display, see page 86 for details.

The optional PIN Activated Security System (P.A.S.S.) is designed to prevent unauthorized use. When enabled, the Tractor cannot be operated until a valid passcode has been entered.

To enable/disable P.A.S.S., follow the procedures below.

#### **ENABLE P.A.S.S.**

##### **NOTICE**

After activating P.A.S.S. for the first time you must power down the Tractor and allow the electronic control module (ECM) to fully shutdown before restarting.

This may take up to three minutes.

Once a new passcode has been enabled, it cannot be changed unless you first disable the system. Then you can re-follow the steps outlined in the ENABLE P.A.S.S. section to enter a new passcode.

1. Press and hold the MODE button to enter the “OPTIONS” menu.
2. Use the UP/DOWN toggle buttons to cycle through options until “REQUIRE PIN TO START” appears. Press the MODE button to select.
3. If required, “ENTER NEW PIN” will appear. Use the UP/DOWN toggle buttons to cycle to your desired first digit. Press the MODE button to select the digit.
4. Continue until all four digits of your desired passcode have been selected. Once finished, “NEW PIN SET” will flash momentarily and then revert back to the “REQUIRE PIN TO START” screen.

Record your passcode for future reference.

5. To enable your new passcode, use the UP/DOWN toggle buttons to change the flashing “OFF” at bottom of screen to “ON”. **If this step is skipped, P.A.S.S. will not be enabled.**
6. Press the MODE button to re-enter the “OPTIONS” menu. The Tractor will now require passcode entry before next startup.

You can exit the “OPTIONS” menu three different ways.

- Toggle to “EXIT” and press the MODE button.
- Hold the MODE button for a few seconds.
- Do nothing, allowing the system to automatically revert back to the main screen.

### NOTICE

If the battery becomes low while the P.A.S.S. system is enabled, the gauge may show "New Tractor Detected" after the battery has been recharged/replaced. Leave the key in the ON position to allow system reconfirmation.

### DISABLE P.A.S.S.

1. Press and hold the MODE button to enter the "OPTIONS" menu.
2. Use the UP/DOWN toggle buttons to cycle through options until "REQUIRE PIN TO START" appears. Press the MODE button to select.
3. Enter current passcode.
4. Use the UP/DOWN toggle buttons to change the flashing "ON" at bottom of screen to "OFF".
5. Press the MODE button to re-enter the "OPTIONS" menu. P.A.S.S. is now disabled.

You can exit the "OPTIONS" menu three different ways.

- Toggle to "EXIT" and press the MODE button.
- Hold the MODE button for a few seconds.
- Do nothing, allowing the system to automatically revert back to the main screen.

## FEATURES AND CONTROLS

### ENGINE ERROR CODES

The error screen displays only when the CHECK ENGINE indicator is on or when it goes on and off during one ignition cycle. Error codes are not stored. When the key is turned OFF, the code and message is lost, but will reappear if the fault reoccurs after restarting the engine.

If the CHECK ENGINE lamp or the EPS lamp illuminates, retrieve the active error codes from the display.

- q Failure Mode Indicator (FMI)
- w Suspect Parameter Number (SPN)
- e Code Count

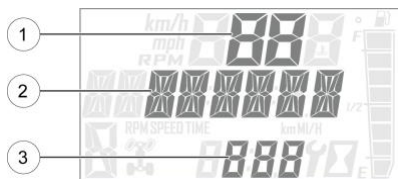

1. Press and hold the MODE button to enter the settings menu.
2. Press either toggle button to cycle to the “DIAGCODE” option. Press MODE to select.
3. More than one diagnostic code may be present. Press the toggle UP button to see if more codes are present. Press MODE to select a code.

#### NOTICE

If the displayed code is an engine fault code, the CHECK ENGINE lamp will blink. If the displayed code is an EPS fault code, the EPS lamp will blink.

4. Record the three (3) numbers displayed.
5. Press MODE to exit to the settings menu.

## DIAGNOSTIC DISPLAY CODE DEFINITIONS

**Open Load:** There is a break in the wires that lead to the item listed in the chart (injector, fuel pump, etc.), or the item has failed.

**Short-to-Ground:** The wire is shorted to ground between the electronic control unit and the item listed in the chart.

**Shorted Load:** The wires leading to the item listed in the chart are shorted together, or the item has shorted internally.

**Short-to-Battery:** The wire leading from the item listed in the chart to the electronic control unit is shorted to a wire at battery voltage.

ENGINE CONTROL MODULE			
COMPONENT	CONDITION	SPN	FMI
Accelerator Position 2	Voltage Above Normal, Or Shorted To High Source	29	3
	Voltage Below Normal, Or Shorted To Low Source		4
Throttle Position Sensor 1	Voltage Above Normal, Or Shorted To High Source	51	3
	Voltage Below Normal, Or Shorted To Low Source		4
Tractor Speed Sensor	Data Erratic, Intermittent Or Incorrect	84	2
Accelerator Position 1	Voltage Above Normal, Or Shorted To High Source	91	3
	Voltage Below Normal, Or Shorted To Low Source		4
	Voltage Above Normal, Or Shorted To High Source		3
	Voltage Below Normal, Or Shorted To Low Source		4
Manifold Absolute Pressure Sensor	Voltage Above Normal, Or Shorted To High Source	102	3
	Voltage Below Normal, Or Shorted To Low Source		4

## FEATURES AND CONTROLS

ENGINE CONTROL MODULE			
COMPONENT	CONDITION	SPN	FMI
Intake Air Temperature Sensor	Data Valid But Above Normal Operational Range - Most Severe Level	105	0
	Voltage Above Normal, Or Shorted To High Source		3
	Voltage Below Normal, Or Shorted To Low Source		4
Barometric Pressure Sensor	Voltage Above Normal, Or Shorted To High Source	108	3
	Voltage Below Normal, Or Shorted To Low Source		4
Engine Temperature Sensor	Data Valid But Above Normal Operational Range - Most Severe Level	110	0
	Data Erratic, Intermittent Or Incorrect		2
	Voltage Above Normal, Or Shorted To High Source		3
	Voltage Below Normal, Or Shorted To Low Source		4
	Abnormal Rate Of Change		10
	Data Valid But Above Normal Operating Range - Moderately Severe Level		18
Fuel Rail Pressure Sensor	Data Erratic, Intermittent Or Incorrect	157	2
	Voltage Above Normal, Or Shorted To High Source		3
	Voltage Below Normal, Or Shorted To Low Source		4
	Data Valid But Above Normal Operating Range - Least Severe Level		15



## FEATURES AND CONTROLS

<b>ENGINE CONTROL MODULE</b>			
<b>COMPONENT</b>	<b>CONDITION</b>	<b>SPN</b>	<b>FMI</b>
	Data Valid But Below Normal Operating Range - Least Severe Level		17
	Data Valid But Below Normal Operational Range - Most Severe Level		1
	Data Erratic, Intermittent Or Incorrect		2
	Voltage Above Normal, Or Shorted To High Source		3
	Voltage Below Normal, Or Shorted To Low Source		4
	Data Valid But Below Normal Operating Range - Moderately Severe Level		18
Engine Speed	Condition Exists	190	31
Gear Sensor Signal	Data Erratic, Intermittent Or Incorrect	523	2
Crankshaft Position Sensor	Data Erratic, Intermittent Or Incorrect	636	2
Injector 1 (Front) (MAG) (SDI Port Injector)	Voltage Above Normal, Or Shorted To High Source	651	3
	Voltage Below Normal, Or Shorted To Low Source		4
	Current Below Normal Or Open Circuit		5
Injector 2 (Rear) (PTO) (SDI Port Injector)	Voltage Above Normal, Or Shorted To High Source	652	3
	Voltage Below Normal, Or Shorted To Low Source		4
	Current Below Normal Or Open Circuit		5

## FEATURES AND CONTROLS

ENGINE CONTROL MODULE			
COMPONENT	CONDITION	SPN	FMI
Starter Solenoid Driver Circuit	Voltage Above Normal, Or Shorted To High Source	677	3
	Voltage Below Normal, Or Shorted To Low Source		4
	Current Below Normal Or Open Circuit		5
Knock Sensor 1	Data Valid But Below Normal Operational Range - Most Severe Level	731	1
Fan Relay Driver Circuit	Voltage Above Normal, Or Shorted To High Source	1071	3
	Voltage Below Normal, Or Shorted To Low Source		4
	Current Below Normal Or Open Circuit		5
Boost Pressure Sensor	Data Valid But Above Normal Operational Range - Most Severe Level	1127	0
	Data Erratic, Intermittent Or Incorrect		2
	Voltage Above Normal, Or Shorted To High Source		3
	Voltage Below Normal, Or Shorted To Low Source		4
	Condition Exists		31
Ignition Coil Primary Driver 1 (Front) (MAG)	Voltage Above Normal, Or Shorted To High Source	1268	3
Ignition Coil Primary Driver 2 (Rear) (PTO)	Voltage Above Normal, Or Shorted To High Source	1269	3
PWM Fuel Pump	Voltage Above Normal, Or Shorted To High Source	1347	3

## FEATURES AND CONTROLS

<b>ENGINE CONTROL MODULE</b>			
<b>COMPONENT</b>	<b>CONDITION</b>	<b>SPN</b>	<b>FMI</b>
	Voltage Below Normal, Or Shorted To Low Source		4
	Current Below Normal Or Open Circuit		5
Fuel Pump Module Errors	Abnormal Frequency Or Pulse Width Or Period		8
	Voltage Below Normal, Or Shorted To Low Source		4
Oxygen Sensor Bank 1 Sensor 1	Data Erratic, Intermittent Or Incorrect	3056	2
	Voltage Above Normal, Or Shorted To High Source		3
	Voltage Below Normal, Or Shorted To Low Source		4
	Bad Intelligent Device Or Component		12
ECU Output Supply Voltage 1	Voltage Above Normal, Or Shorted To High Source	3597	3
	Voltage Below Normal, Or Shorted To Low Source		4
ECU Output Supply Voltage 2	Voltage Above Normal, Or Shorted To High Source	3598	3
	Voltage Below Normal, Or Shorted To Low Source		4
ECU Output Supply Voltage 3	Voltage Above Normal, Or Shorted To High Source	3599	3
	Voltage Below Normal, Or Shorted To Low Source		4
Cylinder Misfire	Mechanical System Not Responding Or Out Of Adjustment	65590	7

## FEATURES AND CONTROLS

ENGINE CONTROL MODULE			
COMPONENT	CONDITION	SPN	FMI
Cylinder 1 Misfire	Mechanical System Not Responding Or Out Of Adjustment	65591	7
Cylinder 2 Misfire	Mechanical System Not Responding Or Out Of Adjustment	65592	7
ETC Accelerator Position Sensor Outputs 1 & 2 Correlation	Data Erratic, Intermittent Or Incorrect	65613	2
Fuel Pump Controller	Abnormal Frequency Or Pulse Width Or Period	66028	8
	Bad Intelligent Device Or Component		12
Throttle Position Sensor 2	Voltage Above Normal, Or Shorted To High Source	520198	3
	Voltage Below Normal, Or Shorted To Low Source		4
Canister Purge Valve	Voltage Above Normal, Or Shorted To High Source	520202	3
	Voltage Below Normal, Or Shorted To Low Source		4
	Current Below Normal Or Open Circuit		5
All Wheel Drive Control Circuit	Voltage Above Normal, Or Shorted To High Source	520207	3
	Voltage Below Normal, Or Shorted To Low Source		4
	Current Below Normal Or Open Circuit		5
Chassis Relay	Voltage Above Normal, Or Shorted To High Source	520208	3

## FEATURES AND CONTROLS

<b>ENGINE CONTROL MODULE</b>			
<b>COMPONENT</b>	<b>CONDITION</b>	<b>SPN</b>	<b>FMI</b>
	Voltage Below Normal, Or Shorted To Low Source		4
	Current Below Normal Or Open Circuit		5
Oxygen Sensor Heater 1	Data Erratic, Intermittent Or Incorrect	520209	2
	Voltage Above Normal, Or Shorted To High Source		3
	Voltage Below Normal, Or Shorted To Low Source		4
	Current Below Normal Or Open Circuit		5
Accelerator Position/Brake Position Interaction	Condition Exists	520275	31
Throttle Position Sensor (1 or 2 Indeterminable)	Data Erratic, Intermittent Or Incorrect	520276	2
	Bad Intelligent Device Or Component		12
Throttle Body Control - Power Stage	Data Erratic, Intermittent Or Incorrect	520277	2
	Voltage Above Normal, Or Shorted To High Source		3
	Voltage Below Normal, Or Shorted To Low Source		4
	Abnormal Frequency Or Pulse Width Or Period		8
Throttle Body Control - Adaption Aborted	Condition Exists	520279	31

## FEATURES AND CONTROLS

ENGINE CONTROL MODULE			
COMPONENT	CONDITION	SPN	FMI
Throttle Body Control - Limp Home Position Check Failed	Condition Exists	520280	31
Throttle Body Control - Mechanical Stop Adaptation Failure	Condition Exists	520281	31
Throttle Body Control - Repeated Adaptation Failed	Condition Exists	520282	31
Throttle Body Control	Voltage Above Normal, Or Shorted To High Source	520283	3
	Voltage Below Normal, Or Shorted To Low Source		4
Throttle Body Control - Position Deviation Fault	Condition Exists	520284	31
Brake Switch (1 or 2 Indeterminable)	Data Erratic, Intermittent Or Incorrect	520285	2
ECU Monitoring Error	Condition Exists	520286	31
ECU Monitoring Error (Level 3)	Condition Exists	520287	31
ECU Monitoring of Injection Cut Off (Level 1)	Condition Exists	520288	31
ECU Monitoring of Injection Cut Off (Level 2)	Condition Exists	520289	31
Throttle Body Control - Requested Throttle Angle Not Plausible	Condition Exists	520305	31

## FEATURES AND CONTROLS

<b>ENGINE CONTROL MODULE</b>			
<b>COMPONENT</b>	<b>CONDITION</b>	<b>SPN</b>	<b>FMI</b>
ECU ADC Fault - No Load	Condition Exists	520306	31
ECU ADC Fault - Voltage	Condition Exists	520307	31
Accelerator Sensor Sync Fault - Sensor Diff Exceeds Limit	Condition Exists	520308	31
ECU Fault - ICO	Condition Exists	520309	31
ECU Fault - Hardware Disruption	Condition Exists	520311	31
Knock Sensor Positive Line	Voltage Above Normal, Or Shorted To High Source	520331	3
	Voltage Below Normal, Or Shorted To Low Source		4
Knock Sensor Negative Line	Voltage Above Normal, Or Shorted To High Source	520332	3
	Voltage Below Normal, Or Shorted To Low Source		4
ECU Monitoring (Pedal Map Mismatch)	Condition Exists	520336	31
Wastegate Solenoid Driver	Voltage Above Normal, Or Shorted To High Source	520341	3
	Voltage Below Normal, Or Shorted To Low Source		4
	Current Below Normal Or Open Circuit		5
Adaptive Fuel Correction Bank 1	Data Valid But Above Normal Operating Range - Least Severe Level	520344	15
	Data Valid But Below Normal Operating Range - Least Severe Level		17

## FEATURES AND CONTROLS

ENGINE CONTROL MODULE			
COMPONENT	CONDITION	SPN	FMI
Intercooler Pump Driver Circuit	Voltage Above Normal, Or Shorted To High Source	520496	3
	Voltage Below Normal, Or Shorted To Low Source		4
	Current Below Normal Or Open Circuit		5
Wideband Oxygen Sensor Bank 1 Sensor 1 Pumping Current Trim	Current Below Normal Or Open Circuit	520612	5
Wideband Oxygen Sensor Bank 1 Sensor 1 Positive Current Control	Current Below Normal Or Open Circuit	520613	5
Wideband Oxygen Sensor Bank 1 Sensor 1 Negative Current Control	Current Below Normal Or Open Circuit	520614	5
Wideband Oxygen Sensor Bank 1 Sensor 1 Reference Voltage	Current Below Normal Or Open Circuit	520615	5
Wideband Chip	Bad Intelligent Device Or Component	520679	12
Start Switch	Data Erratic, Intermittent Or Incorrect	521083	2

EPAS MODULE			
COMPONENT	CONDITION	SPN	FMI
Steering Over Current Shut Down	Current Above Normal Or Grounded Circuit	520221	6
Steering Excessive Current Error	Current Above Normal Or Grounded Circuit	520222	6



## FEATURES AND CONTROLS

<b>EPAS MODULE</b>			
<b>COMPONENT</b>	<b>CONDITION</b>	<b>SPN</b>	<b>FMI</b>
Steering Torque Partial Failure	Condition Exists	520223	31
Steering Torque Full Failure	Condition Exists	520224	31
EPAS Inverter Temperature	Data Valid But Above Normal Operational Range - Most Severe	520225	0
	Data Valid But Above Normal Operating Range - Severe		18
EPAS Communications Receive Data Error	Data Erratic, Intermittent Or Incorrect	520226	2
	Condition Exists	520226	31
Position Encoder Error	Root Cause Not Known	520228	11
	Bad Intelligent Device Or Component	520228	12
	Condition Exists	520228	31
EPAS Software Error	Bad Intelligent Device Or Component	520229	12
	Condition Exists	520229	31
EPAS Power Save Condition	Condition Exists	520231	31
EPS SEPIC Voltage Error	Voltage Above Normal, Or Shorted To High Source	524086	3
	Voltage Below Normal, Or Shorted To Low Source	524086	4
Calibration CRC	Checksum/CRC Error	630	13
Steering Torque Full Failure	Torque Sensor Out of Range	520223	31
	Torque Sensor Linearity Error	520224	31

## FEATURES AND CONTROLS

EPAS MODULE			
COMPONENT	CONDITION	SPN	FMI
EPS CAN Communications Receive Error	No RX Message for {{cal parameter}} seconds	520226	2
Tractor Speed	Tractor Speed Too High	84	0
	Tractor Speed Implausible		10
	Received Tractor Speed has Errors		19
Engine Speed	Engine Speed Too High	190	0
	Received Engine Speed has Errors	190	19
Battery Voltage	Too High	188	3
Battery Voltage	Too Low	188	4
Position Encoder Error	Loss of SPI Communication	520228	12
	Encoder Variance Error		31
EPS Software Error	Manufacturing CRC Error	520229	12
	Boot Count Error		31
ICS Communication	Loss of CAN between EPS and Instrument Cluster	520230	31
EPAS Power Save	5 minute time out	520231	31
ECU Memory	EEPROM Communication Error	628	12
	Application CRC Error		13
VGD Low	VGD Low	524086	4
Absolute Position Sensor	Absolute Position Sensor Out of Range	1807	31
	Absolute Position Sensor Not Calibrated	1807	13

## FEATURES AND CONTROLS

<b>SUSPENSION CONTROL MODULE</b>			
<b>COMPONENT</b>	<b>CONDITION</b>	<b>SPN</b>	<b>FMI</b>
Tractor Speed Sensor	Data Drifted High	84	20
	Data Drifted Low		21
Transmission Requested Range Data	Data Erratic, Intermittent Or Incorrect	182	2
Suspension Mode Switch Input	Data Erratic, Intermittent Or Incorrect	518098	2
	Voltage Above Normal, Or Shorted To High Source		3
	Voltage Below Normal, Or Shorted To Low Source		4
Valve Driver Front Left	Voltage Above Normal, Or Shorted To High Source	518106	3
	Voltage Below Normal, Or Shorted To Low Source		4
Valve Driver Front Right	Voltage Above Normal, Or Shorted To High Source	518107	3
	Voltage Below Normal, Or Shorted To Low Source		4
Valve Driver Rear Left	Voltage Above Normal, Or Shorted To High Source	518108	3
	Voltage Below Normal, Or Shorted To Low Source		4
Valve Driver Rear Right	Voltage Above Normal, Or Shorted To High Source	518109	3
	Voltage Below Normal, Or Shorted To Low Source		4
Shock Valve Power Supply Relay Driver	Voltage Above Normal, Or Shorted To High Source	518110	3
	Voltage Below Normal, Or Shorted To Low Source		4

## FEATURES AND CONTROLS

SUSPENSION CONTROL MODULE			
COMPONENT	CONDITION	SPN	FMI
Absolute Shock Current Error - Front Left	Root Cause Not Known	518111	11
Absolute Shock Current Error - Front Right	Root Cause Not Known	518112	11
Absolute Shock Current Error - Rear Left	Root Cause Not Known	518113	11
Absolute Shock Current Error - Rear Right	Root Cause Not Known	518114	11
Internal Inertial Measurement Unit	Bad Intelligent Device Or Component	518115	12
	Data Valid But Above Normal Operating Range - Least Severe Level		15
	Data Valid But Below Normal Operating Range - Least Severe Level		17
CAN Message PGN 65382	Abnormal Update Rate	518118	9
CAN Message PGN 65396	Abnormal Update Rate	518117	9
CAN Message PGN 65314	Abnormal Update Rate	518118	9
SW Version & HW Version Mismatch	Data Erratic, Intermittent Or Incorrect	518119	2
CAN Message PGN 65265	Abnormal Update Rate	518120	9
CAN Message PGN 61445	Abnormal Update Rate	518121	9

## FEATURES AND CONTROLS

<b>SUSPENSION CONTROL MODULE</b>			
<b>COMPONENT</b>	<b>CONDITION</b>	<b>SPN</b>	<b>FMI</b>
Steering Angle Adoption Offset	Data Valid But Above Normal Operating Range - Least Severe Level	518122	15
Tractor Speed Data	Data Erratic, Intermittent Or Incorrect	518123	2
	Data Drifted High		20
Suspension Control Module	Bad Intelligent Device Or Component	518124	12
CAN 1	Root Cause Not Known	518125	11
System Voltage	Data Valid But Above Normal Operational Range - Most Severe Level	518126	0
	Data Valid But Below Normal Operational Range - Most Severe Level		1
	Voltage Above Normal, Or Shorted To High Source		3
	Voltage Below Normal, Or Shorted To Low Source		4
	Data Valid But Above Normal Operating Range - Moderately Severe Level		18
	Data Valid But Below Normal Operating Range - Moderately Severe Level		18
Raw Brake Switch Status	Data Erratic, Intermittent Or Incorrect	520572	2
Normalized Accelerator Pedal Position	Data Erratic, Intermittent Or Incorrect	520574	2

## FEATURES AND CONTROLS

<b>SUSPENSION CONTROL MODULE</b>			
<b>COMPONENT</b>	<b>CONDITION</b>	<b>SPN</b>	<b>FMI</b>
Engine Speed Data	Data Erratic, Intermittent Or Incorrect	524000	2
Steering Angle Input	Data Erratic, Intermittent Or Incorrect	524114	2

# RIDE COMMAND DISPLAY (IF EQUIPPED)

## BEFORE YOU RIDE

Before riding with your new display, do the following:

- Read this and the Ride Command User's Guide in their entirety.
- Familiarize yourself with the features and operations of the Display while the Tractor is stationary.
- Download the Egimotors RIDE COMMAND App from the Apple® App Store® or Google Play® store and create your personalized account.
- Check your display to ensure you have the appropriate maps and trails visible for your area. To change or update maps/trails see page 92.
- Check <https://www.Egimotors.com/en-us/owners-manuals/> for the latest updates to the owner's manual.

### NOTICE

Trails change often, and the trail data file is only considered valid for 90 days after the release date. Please keep your trail data up to date. Download the latest trails at <http://ridecommand.Egimotors.com>.

### NOTICE

Using the display for an extended period of time while the Tractor's engine is off can drain the battery.

## DEVICE OPERATING REQUIREMENTS

Phone functionality is dependent on the capabilities of your cell phone.

### NOTICE

Some cell phones or operating systems will not work as shown in this manual.

## RIDE COMMAND DISPLAY (IF EQUIPPED)

### OVERVIEW

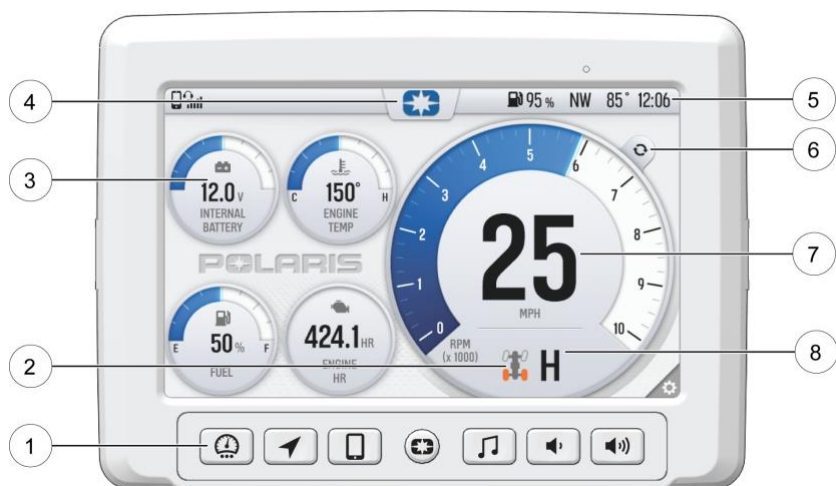

q Ride Command Buttons

w Driveline Mode

e Widgets

r Settings

t Icon Bar

y Gauge View Mode

u Speedometer/Tachometer





i Gear Status

### RIDE COMMAND BUTTONS

BUTTON	DESCRIPTION	FUNCTION
	Menu Button	Press the Menu button to access the settings. To reboot the display, press and hold for 5 seconds.
	Gauge Screen Button	Press the Gauge Screen button to select from available screens.



## RIDE COMMAND DISPLAY (IF EQUIPPED)

BUTTON	DESCRIPTION	FUNCTION
	Map Button	Press the Map button to access the map, manage your rides and waypoints, and to see your friends on the map with Group Ride.
	Phone Button	Press the Phone button to access your Bluetooth® connected phone, including recent calls, contacts, dialer, and messages.
	Audio Button	Press the Audio button to access the Radio, Weather, USB, and connected Bluetooth® music interface
	Volume Decrease Button	Press the Volume Decrease button to decrease the volume. Press and hold to mute volume.
	Volume Increase Button	Press the Volume Increase button to increase the volume.

## RIDE COMMAND DISPLAY (IF EQUIPPED)

---

### **PIN ACTIVATED SECURITY SYSTEM (P.A.S.S.) (IF EQUIPPED) — RIDE COMMAND**

The optional PIN Activated Security System (P.A.S.S.) is to prevent unauthorized use. When enabled, the Tractor cannot be operated until a valid passcode has been entered using the Ride Command display screen.

#### **ENABLE P.A.S.S.**

##### *NOTICE*

After activating P.A.S.S. for the first time you must power down the Tractor and allow the electronic control module (ECM) to fully shutdown before restarting. This may take up to three minutes.

1. Go to the settings menu by pressing the Menu button.
2. Select Tractor Settings from the left toolbar.
3. Select Engine Start Lockout.
4. If this your first time activating P.A.S.S. you will be prompted to enter a new passcode. Enter and verify new passcode.  
Record your passcode for future reference.
5. Turn Engine Start Lockout from No to Yes.
6. Turn off the Tractor using the key ignition switch.

##### *NOTICE*



If the battery becomes low while the P.A.S.S. system is enabled, the gauge may show "New Tractor Detected" after the battery has been recharged/replaced. Leave the key in the ON position to allow system reconfirmation.

#### **DISABLE P.A.S.S.**

1. Go to the settings menu by pressing the Menu button.
2. Select Tractor Settings from the left toolbar.
3. Select Engine Start Lockout.
4. Enter passcode to disable P.A.S.S.
5. Turn Engine Start Lockout from Yes to No.

## RIDE COMMAND DISPLAY (IF EQUIPPED)

### DRIVELINE MODE

INDICATOR	DESCRIPTION	FUNCTION
	2WD	When the switch is on 2X4, the Tractor is in two-wheel drive at all times.
	AWD	When in All-Wheel Drive, the demand drive unit will automatically engage any time the rear wheels lose traction. When the rear wheels regain traction, the demand drive unit will automatically disengage. There is no limit to the length of time the Tractor may remain in 4X4. The Tractor automatically engages 4X4 when operating in reverse if the switch is set to 4X4 position.
	Turf Mode (if equipped)	When operating in TURF mode, the inside rear wheel will rotate independently from the outside wheel during turns. Operate in TURF mode only as needed to protect smooth, level surfaces from tire damage. <b>DO NOT</b> operate in TURF mode when climbing or descending hills, when sidehilling, or when operating on uneven, loose, or slippery terrain such as sand, gravel, ice, snow, obstacles, and water crossings. Always operate in AWD on these types of terrain.

## RIDE COMMAND DISPLAY (IF EQUIPPED)

### GAUGE SCREENS

Press the Gauge Screen button to toggle between gauge screens. The display comes loaded with two different gauge screens. Additional gauge screens can be added or deleted.

Each gauge screen is customizable and can be set up in the following configurations:

- Four round widgets
- Two round widgets and a list of three data values
- A list of five data values

To customize your gauge screens, press the gear icon located in the lower right corner of the display.



### SETTINGS

From the setting menu you can view Tractor information, manage Bluetooth® devices, update display software, and more.

To access the Setting menu, press the Menu button  $\mathcal{Q}$ .

You can also navigate to the settings menu by pressing the EGIMOTORS logo at the top of the display screen  $\mathcal{W}$ . This will open the Control Panel. From the Control Panel, select the settings tab, then press the **All Settings** button located in the lower right corner of the display screen.



## RIDE COMMAND DISPLAY (IF EQUIPPED)

### GAUGE VIEW MODE

Press **q** to toggle between the two available gauge view modes, **Analog** and **Digital**.

While in the digital gauge view mode, press **w** to invert the MPH and RPM units.



### DISPLAY MODE

From the Control tab **e**, select the display mode from the available options **y**.

The display mode can be set to Day, Night, or AUTO mode.

#### Day Mode



#### Night Mode



## RIDE COMMAND DISPLAY (IF EQUIPPED)

### ICON BAR



ICON	DESCRIPTION	FUNCTION
q	Headset	Displays icon if headset is connected
w	Signal Strength	Displays current cell signal strength
e	Wireless Internet Signal Strength (if equipped)	Displays current wireless internet signal strength (if equipped)
r	Fuel Level	Displays current fuel capacity percentage
t	Tractor Direction	Displays Tractor direction
y	Ambient Temperature	Displays ambient temperature
u	Clock	Displays current time

### UPDATE SOFTWARE

#### NOTICE

Before updating the Display, always export your existing rides and waypoints to a USB drive to avoid losing them.

To update the software, do the following:

#### ON YOUR PERSONAL COMPUTER

1. Go to [ridecommand.Egimotors.com/update](http://ridecommand.Egimotors.com/update).
2. Log into your account, or create a new account.
3. Using the Tractor Identification Number (VIN), add your new Egimotors Tractor to your Garage.
4. Locate and download the latest software to a USB flash drive (8+ GB).

#### ON YOUR TRACTOR

1. Connect the USB flash drive to the USB cable and power up your Tractor.
2. On the RIDE COMMAND display, select the Settings menu on your display by pressing the EGIMOTORS icon at the top of the screen.
3. Select General Settings, then Update Software.
4. Select the file you wish to load (use date listed in the file name to determine most recent file).
5. Select Yes to restart display (restart required).

#### ERROR MESSAGES

If an error occurs while updating your software, perform one or all of the following actions to resolve the issue:

1. Remove and reconnect the USB flash drive securely.
2. Make sure the display files are not inside a folder on the flash drive.
3. Make sure only display files are on the flash drive. Remove any other files if necessary.
4. Try using a different USB flash drive.

## RIDE COMMAND DISPLAY (IF EQUIPPED)

---

### UPDATE MAPS

To update the maps on your display, do the following:

1. Go to [ridecommand.Egimotors.com/update](http://ridecommand.Egimotors.com/update) and download the map update to a USB flash drive.
2. Insert USB flash drive into the USB port on your Tractor.
3. Press the Update maps in the General Settings.
4. Select the file you want to install by pressing the corresponding down arrow icon.
5. This will update the display's map which will automatically restart the display once the update is complete. Do not remove the USB flash drive until the display has fully restarted.

### USB HARDWARE

#### SOFTWARE UPDATES

For software update, EGIMOTORS recommends using a SanDisk® or similar USB flash drive with a minimum of 4GB in available memory, formatted using the FAT32 or exFAT® file systems. For best results remove all files from the flash drive before starting the update process.

#### MAP UPDATES

For Map updates, a 32GB USB drive is required (USB 3.0 drive is highly recommended) USB drive must be formatted to exFAT® before copying the map file onto it.

#### TRAIL UPDATES

For Trail updates, a 4GB drive formatted to FAT32 can be used.



## OPERATION

### TRACTOR BREAK-IN

#### ENGINE AND DRIVETRAIN BREAK-IN

1. Fill the fuel tank with the recommended fuel. See the Refueling section for details. Always exercise extreme caution whenever handling fuel.
2. Check the oil level. See the Oil Check section for details. Add the recommended oil as needed to maintain the oil level in the safe operating range.
3. Avoid aggressive use of the brakes.
4. Vary throttle positions. Do not operate at sustained idle.
5. Perform regular checks on fluid levels, controls and areas outlined on the daily pre-ride inspection checklist.
6. Carry only light loads.
7. During the break-in period, change both the oil and the filter at 25 hours, one month, or 500 miles, whichever comes first.
8. Check fluid levels of transmission and all gearcases after the first 25 hours of operation and every 50 hours thereafter.

#### BRAKE SYSTEM BREAK-IN

Apply only moderate braking force for the first 50 stops. Aggressive or overly forceful braking when the brake system is new could damage brake pads and rotors.

## OPERATION

---

### **PVT BREAK-IN (CLUTCHES / BELT)**

A proper break-in of the clutches and drive belt will ensure a longer life and better performance. If a belt fails, always clean any debris from the duct and from the engine compartment.

#### ***STANDARD BREAK-IN***

Drive at slower speeds for the first 50 miles (80 km) of operation. Carry only light loads. Avoid aggressive acceleration, high-speed operation and prolonged operation at a specific RPM during this period.

#### ***SAND / DUNE BREAK-IN***

Drive in low gear for the first 5 miles (8 km) of operation. Avoid prolonged low speed operation at high throttle. Avoid aggressive acceleration, high-speed operation and prolonged operation at a specific RPM during this period.

#### ***BELT LIFE***

To extend belt life, use low gear in the following conditions:

- When hauling or towing heavy cargo
- When consistently operating at speeds less than 35 MPH (56 km/h) in hard-pulling terrain, such as mud, rocks or sand/dune environments.

---

## OPERATING GUIDELINES

### STARTING THE ENGINE

#### NOTICE

Operating the Tractor immediately after starting could cause engine damage. Allow the engine to warm up for several minutes before operating the Tractor.

1. Position the Tractor on a level surface outdoors or in a well-ventilated area.
2. Sit in the driver's seat and fasten the seat belt. Always make sure all cab doors are closed and latched when riding in this Tractor.
3. Place the transmission in PARK.
4. Apply the brakes. Do not press the throttle pedal while starting the engine.
5. Turn the ignition key past the ON/RUN position and release immediately to START. The engine will turn over for a maximum five seconds until the Tractor has started.
6. If the engine does not start within five seconds, return the ignition switch to the OFF position and wait five seconds. Repeat steps 5 and 6 until the engine starts.
7. After starting the engine, wait 10 seconds before applying throttle.

### BRAKING

1. Release the throttle pedal completely.

#### TIP

When the throttle pedal is released completely and engine speed slows to near idle, the Tractor has no engine braking.

2. Press on the brake pedal evenly and firmly.
3. Practice starting and stopping (using the brakes) until you're familiar with the controls.

## OPERATION

---

### DRIVING IN REVERSE

 WARNING

Before shifting into reverse, use extra care to make sure the area is clear of people or obstacles. When it's safe to proceed, back slowly.

Follow these precautions when operating in reverse:

1. Always check for obstacles or people behind the Tractor.
2. Apply the throttle *lightly*. Never open the throttle suddenly.
3. Back slowly.
4. Apply the brakes *lightly* for stopping.
5. Avoid making sharp turns.

### STOPPING THE ENGINE AND PARKING THE TRACTOR

 WARNING

When leaving the Tractor on an incline is unavoidable, use extra care. Tractor rollaway can cause serious injury or death. This Tractor can roll whenever the gear selector is not in the PARK (P) position. Always shift to PARK (P) when stopping the engine or leaving the Tractor. If leaving the Tractor unattended, block the rear wheels on the downhill side and keep children, pets, and others away from the gear selector.

To park the Tractor:

1. Stop the Tractor on a level surface.
2. Place the transmission in PARK (P). This Tractor can roll whenever the transmission is not in the PARK (P) position.
3. Stop the engine.
4. Engage the park brake (if equipped).
5. Remove the ignition key to prevent unauthorized use.

---

## WINCH GUIDE

### WINCH SAFETY

These safety warnings and instructions apply if your Tractor came equipped with a winch or if you choose to add an accessory winch to your Tractor.

 **WARNING**

Improper winch use can result in SEVERE INJURY or DEATH. Always follow all winch instructions and warnings in this manual.

Your winch may have a cable made of either wire rope or specially designed synthetic rope. The term "winch cable" will be used for either unless noted otherwise.

### WINCH SAFETY PRECAUTIONS

1. Read all sections of this manual.
2. Never use alcohol or drugs before or while operating the winch.
3. Never allow children under 18 years of age to operate the winch.
4. Always wear eye protection and heavy gloves when operating the winch.
5. Always keep body, hair, clothing and jewelry clear of the winch cable, fairlead and hook when operating winch.
6. Never attempt to "jerk" a load attached to the winch with a moving Tractor. See the *Shock Loading* section on page 105.
7. Always keep the area around the Tractor, winch, winch cable, and load clear of people (especially children) and distractions while operating the winch.
8. Always turn the Tractor ignition power OFF when it and the winch are not being used.
9. Always be sure that at least five (5) full turns of winch cable are wrapped around the winch drum at all times. The friction provided by this wrapped cable allows the drum to pull on the winch cable and move the load.
10. Always apply your Tractor's park brake and/or park mechanism to hold the Tractor in place during winching. Use wheel chocks if needed.
11. Always align the Tractor and winch with the load directly in front of the Tractor as much as possible. Avoid winching with the winch cable at an angle to the winching Tractor's centerline whenever possible.

## WINCH GUIDE

---

12. If winching at an angle is unavoidable, follow these precautions:
  - a. Look at the winch drum occasionally. Never let the winch cable “stack” or accumulate at one end of the winch drum. Too much winch cable at one end of the winch drum can damage the winch and the winch cable.
  - b. If stacking occurs, stop winching. Follow step 15 of Winch Operation to feed and rewind the cable evenly before continuing the winch operation.
13. Never winch up or down at sharp angles. This can destabilize the winching Tractor and possibly cause it to move without warning.
14. Never attempt to winch loads that weigh more than the winch’s rated capacity.
15. The winch motor may become hot during winch use. If you winch for more than 45 seconds, or if the winch stalls during operation, stop winching and permit the winch to cool down for 10 minutes before using it again.
16. Never touch, push, pull or straddle the winch cable while winching a load.
17. Never let the winch cable run through your hands, even if wearing heavy gloves.
18. Never release the clutch on the winch when the winch cable is under load.
19. Never use the winch for lifting or transporting people.
20. Never use the winch to hoist or suspend a vertical load.
21. Always inspect your winch and winch cable before each use.
22. Never winch the hook fully into the winch. This can cause damage to winch components.
23. Unplug the remote control from the Tractor when the winch is not in use to prevent inadvertent activation and use by unauthorized persons.
24. Never grease or oil the winch cable. This will cause the winch cable to collect debris that will shorten the life of the cable.



## WINCH OPERATION

Read the Winch Safety Precautions in the preceding pages before using your winch.

### TIP

Consider practicing the operation and use of your winch before you actually need to use it in the field.

### ⚠ WARNING

Improper winch use can result in **SEVERE INJURY** or **DEATH**. Always follow all winch instructions and warnings in this manual.

Each winching situation is unique.

- Take your time to think through the winching you are about to do.
  - Proceed slowly and deliberately.
  - Never hurry or rush during winching.
  - Always pay attention to your surroundings.
  - You may need to change your winching strategy if it is not working.
  - Always remember that your winch is very powerful.
  - There are simply some situations that you and your winch will not be able to deal with. Do not be afraid to ask others to help when this happens.
1. Always inspect the Tractor, winch, winch cable and winch controls for any signs of damage or parts in need of repair or replacement before each use. *Pay particular attention to the first 3 feet (1 meter) of winch cable if the winch is being used (or has been used) for lifting an accessory plow assembly.* Promptly replace any worn or damaged cable.
  2. Never operate a winch or a Tractor in need of repair or service.
  3. Always apply your Tractor's park brake and/ or park mechanism to hold the Tractor in place during winching. Use wheel chocks if needed.
  4. Always use the hook strap when handling the hook.

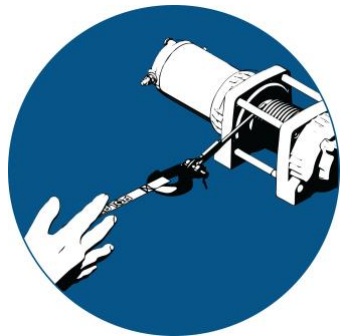

## WINCH GUIDE

### ⚠ WARNING

Never put your fingers into the hook. This could lead to SEVERE INJURY.

- Attach the hook itself onto the load or use a tow strap or chain to secure the load to the winch cable.



### TIP

A “tow strap” is NOT intended to stretch. A “recovery strap” is designed to stretch.

### ⚠ WARNING

Never use a recovery strap when winching due to the excessive energy that can be released if the winch cable breaks. This can result in SEVERE INJURY or DEATH. See the *Shock Loading* section on page 105.

- Never hook the winch cable back onto itself. This will damage the winch cable and may result in winch cable failure.

### ⚠ WARNING

Replace the winch cable at the first sign of damage to prevent SEVERE INJURY or DEATH in the event of failure. For your safety, always replace EGIMOTORS winch parts (including the cable) with genuine EGIMOTORS replacement parts available at your authorized EGIMOTORS dealer, or other qualified dealer.



- If possible, keep the winch cable aligned with the centerline of the winching Tractor. This will help the spooling of the winch cable and reduce the load on the fairlead.
- If freeing a stuck Tractor by attaching to a tree, use an item such as a tow strap to avoid damaging the tree during winch operation. Sharp cables and chains can damage and even kill trees. Please remember to TreadLightly<sup>SM</sup> (treadlightly.org).
- Before operating the winch, be sure that the safety latch on the winch cable hook is fully seated when the load is attached.
- Never operate your winch with a damaged hook or latch. Always replace damaged parts before using the winch.

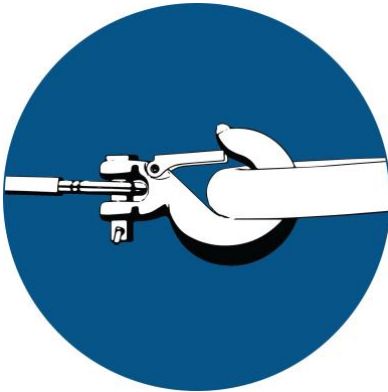

5. Never remove the hook strap from the hook.
6. Release the winch clutch and pull out the winch cable.
7. Pulling out as much cable as possible maximizes the winch's pulling capacity. Always be sure that at least five (5) full turns of winch cable are wrapped around the winch drum at all times. The friction provided by this wrapped cable allows the drum to pull on the winch cable and move the load.
8. Read and adhere to the following information for winch damping to ensure safe winch use.
  - a. In order to absorb energy that could be released by a winch cable failure, always place a "damper" on the winch cable. A damper can be heavy jacket, tarp, or other soft, dense object. A damper can absorb much of the energy released if a winch cable breaks when winching. Even a tree limb can help as a damper if no other items are available to you.
  - b. Lay the damper on top of the mid-point of the winch cable length that is spooled out.

## WINCH GUIDE

---

- c. On a long pull, it may be necessary to stop winching so that the damper can be repositioned to the new mid-point of the winch cable. Always release the tension on the winch cable before repositioning the damper.
  - d. Avoid being directly in line with the winch cable whenever possible. Also, never permit others to stand near or in line with the winch cable during winch operation.
9. Never hook the winch cable back onto itself. This will damage the winch cable and may result in winch cable failure.
10. Never use straps, chains or other rigging items that are damaged or worn.
11. The ONLY time a winch-equipped Tractor should be moving when using the winch is when that Tractor itself is stuck. The winch equipped Tractor should NEVER be in motion to “shock” load the winch cable in an attempt to move a second stuck Tractor. See the Shock Loading section on page 105. For your safety, always follow these guidelines when winching a Tractor free:
- a. Release the winch clutch and spool out the necessary length of winch cable.
  - b. Align the winch cable as close as possible to the winching Tractor’s centerline.
  - c. Attach the winch cable hook to the anchor point or the stuck Tractor’s frame following instructions in this manual.
  - d. Re-engage the clutch on the winch.
  - e. Slowly winch in the slack in the winch cable.
  - f. Select the proper Tractor gear to propel the stuck Tractor in the direction of winching.
  - g. Shift to the lowest gear available on the stuck Tractor.
  - h. Slowly and carefully apply Tractor throttle and winch together to free the Tractor.
  - i. Stop winching as soon as the stuck Tractor is able to propel itself without the help of the winch.
  - j. Detach the winch cable hook.
  - k. Rewind the winch cable evenly back onto the winch drum following the instructions in this manual.
12. Never attempt to winch another stuck Tractor by attaching the winch cable to a suspension component, brush guard, bumper or cargo rack. Tractor damage may result. Instead, attach the winch to a strong portion of the Tractor frame or hitch.

13. Extensive winching will run down the battery on the winching Tractor. Let the winching Tractor's engine run while operating the winch to prevent the battery from running low if winching for long periods.
14. The winch motor may become hot during winch use. If you winch for more than 45 seconds, or if the winch stalls during operation, stop winching and permit the winch to cool down for 10 minutes before using it again.
15. After winching is complete, especially if winching at an angle, it may be necessary to re-distribute the winch cable across the winch drum. You will need an assistant to perform this task.
  - a. Release the clutch on the winch.
  - b. Feed out the winch cable that is unevenly bunched up in one area.
  - c. Re-engage the winch clutch.
  - d. Have an assistant pull the winch cable tightly with about 100 lbs. (45 kg) of tension using the hook strap.
  - e. Slowly winch the cable in while your assistant moves the end of the winch cable back and forth horizontally to evenly distribute the winch cable on the drum.
  - f. Doing this reduces the chances of the winch cable "wedging" itself between lower layers of winch cable.

### WINCH CABLE CARE

#### WARNING

Use of worn or damaged cable could lead to sudden failure and SEVERE INJURY.

For your safety, always replace EGIMOTORS winch parts (including the cable) with genuine EGIMOTORS replacement parts available at your authorized EGIMOTORS dealer, or other qualified person.

1. Always inspect your winch before each use. Inspect for worn or loose parts including mounting hardware. Never use the winch if any part needs repair or replacement.
2. Always inspect your winch cable before each use. Inspect for worn or kinked winch cable.

A kinked winch cable made of wire rope is shown at right. Even after being “straightened out,” this cable has already been permanently and severely damaged. Promptly discontinue use of a winch cable in this condition.

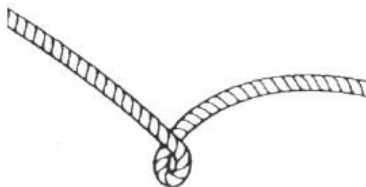

A kinked winch cable made of wire rope that has been “straightened out” is shown at right. Even though it may look usable, the cable has been permanently and severely damaged. It can no longer transmit the load that it could prior to kinking. Promptly discontinue use of a winch cable in this condition.



A winch cable made of synthetic rope should be inspected for signs of fraying. Replace the cable if fraying is observed (shown below). Promptly discontinue use of a winch cable in this condition. Also replace the winch cable if there are fused or melted fibers. Such an area of the synthetic rope will be stiff and appear smooth or glazed. Promptly discontinue use of a winch cable in this condition.



## SHOCK LOADING

### WARNING

Your winch cable is very strong but it is NOT designed for dynamic, or “shock” loading. Shock loading may tension a winch cable beyond its strength and cause the cable to break. The end of a broken winch cable under such high loading can cause SEVERE INJURY or DEATH to you and other bystanders.

*Winch cables are designed to NOT absorb energy. This is true of both wire-rope and synthetic-rope winch cables.*

1. Never attempt to “jerk” a load with the winch. For example, never take up slack in the winch cable by moving the winching Tractor in an attempt to move an object. This is a dangerous practice. It generates high winch cable loads that may exceed the strength of the cable. Even a slowly moving Tractor can create large shock loads in a winch cable.

### WARNING

SEVERE INJURY or DEATH can result from a broken winch cable.

2. Never quickly turn the winch ON and OFF repeatedly (“jogging”). This puts extra load on the winch, winch cable, and generates excessive heat from the motor. This is a form of shock loading.
3. Never tow a Tractor or other object with your winch. Towing an object with a winch produces shock loading of the cable even when towing at slow speeds. Towing from a winch also positions the towing force high on the Tractor. This can cause instability of the Tractor and possibly lead to an accident.
4. Never use recovery straps with your winch. Recovery straps are designed to stretch and can store energy. This stored energy in the recovery strap is released if a winch cable fails making the event even more hazardous. Similarly, never use elastic “bungee” cords for winching.
5. Never use the winch to tie down a Tractor to a trailer or other transportation Tractor. This type of use also causes shock loading that can cause damage to the winch, winch cable, or Tractors used.

**Your winch cable is designed and tested to withstand the loads produced by the winch motor when operated from a stationary Tractor. Always remember that the winch and winch cable are NOT designed for shock loading.**

### WINCH MAINTENANCE AND SERVICE SAFETY

 **WARNING**

Improper or lack of winch maintenance and service could lead to **SEVERE INJURY** or **DEATH**. Always follow all winch instructions and warnings in this manual.

1. Always inspect your winch before each use. Inspect for worn or kinked winch cable. Also inspect for worn or loose parts including mounting hardware.
2. Permit your winch motor to cool down prior to servicing your winch.
3. Never work on your winch without first disconnecting the battery connections to prevent accidental activation of the winch.
4. For your safety, always replace EGIMOTORS winch parts (including the cable) with genuine EGIMOTORS replacement parts available at your authorized EGIMOTORS dealer, or other qualified person.
5. Some winch models use wire rope as the winch cable. Other winches use a specially designed synthetic rope as the winch cable.
6. Never replace a synthetic-rope winch cable with a consumer-grade polymer rope such as can be purchased in a hardware store. Although they may look similar, they are **NOT** alike. A polymer rope not designed for winch use will stretch and store excessive energy when winching.

 **WARNING**

Failure of a stretched rope under winching conditions will release all of the stored energy. This will increase the chances of **SEVERE INJURY** or **DEATH**.

### **EMISSION CONTROL SYSTEMS**

#### **NOISE EMISSION CONTROL SYSTEM**

Do not modify the engine, intake or exhaust components, as doing so may affect compliance with local noise level requirements.

#### **CRANKCASE EMISSION CONTROL SYSTEM**

This engine is equipped with a closed crankcase system. Blow-by gases are forced back to the combustion chamber by the intake system. All exhaust gases exit through the exhaust system.

#### **EXHAUST EMISSION CONTROL SYSTEM**

Exhaust emissions are controlled by engine design. An electronic fuel injection (EFI) system controls fuel delivery. The engine and EFI components are set at the factory for optimal performance and are not adjustable.

The emissions label is located on the left front frame of the Tractor.

#### **ELECTROMAGNETIC INTERFERENCE**

This Tractor complies with EMC requirements of UN ECE Regulation 10 and European directives 97/24/EC and 2004/108/EC.

Non-ionizing Radiation: This Tractor emits some electromagnetic energy. People with active or non-active implantable medical devices (such as heart monitoring or controlling devices) should review the limitations of their device and the applicable electromagnetic standards and directives that apply to this Tractor.





## MAINTENANCE

### PERIODIC MAINTENANCE

 WARNING

Do not attempt any maintenance procedures that are not described in this manual or that you are not comfortable performing. Some maintenance procedures are more extensive and may require special training, tools, and equipment. An authorized EGIMOTORS dealer can perform any service that may be necessary for your Tractor.

 WARNING

Be sure to properly reinstall all components that were removed during any maintenance. For example, some parts are made and positioned to deflect heat, and failing to reinstall heat shields properly can lead to a fire.

 WARNING

Hot parts can cause burns. To avoid burns, do not touch hot components or attempt maintenance before allowing to cool. Surfaces that could be hot during and after operation can include components of the:

- Engine and exhaust
- Brakes
- Shock absorbers

 WARNING

Before service or maintenance, make sure the transmission is in Park and the engine is off with the key removed. Moving parts can contact body parts or clothing. Running the engine while servicing can lead to serious injury, electric shock, burns, fire, carbon monoxide poisoning, and death.

 WARNING

Do not run engine with any covers removed. Contact with exposed belt or moving parts can cause serious injury.

## MAINTENANCE

### WARNING

Tractor fluids such as oil or brake fluid can be hazardous. Wear gloves and avoid skin contact. Always follow the handling and disposal instructions provided by the fluid manufacturer.

## SEVERE USE DEFINITION

Tractors subjected to heavy or severe use patterns must be inspected and serviced more frequently. Tractors subjected to severe use must be serviced at 50% of the stated interval. Examples of severe use include:

- Frequent immersion in mud, water, or sand
- Prolonged low speed, heavy load operation
- Extended idle
- Sustained high-RPM use
- Frequent short trip operation in cold weather (engine frequently does not operate long enough to reach full operating temperature)

### IMPORTANT

Pay special attention to the oil level. A rise in oil level during cold weather can indicate contaminants collecting in the oil sump or crankcase. Change oil immediately if the oil level begins to rise. Monitor the oil level, and if it continues to rise, discontinue use and determine the cause. Your EGIMOTORS dealer or other authorized person can assist.

## EGIMOTORS MAINTENANCE SCHEDULE

The intervals shown are based on Tractors operated under normal conditions.

Each interval is given in hours and miles (kilometers). Items should be serviced at whichever interval comes first following the **Initial Break-In Service**.

Continue to reference the following maintenance schedules at the given intervals as hours and miles (kilometers) increase on the Tractor.

*Tractors subjected to severe use must be serviced at 50% of the stated interval. Examples of Severe Use: Frequent immersion in mud, water, or sand, constant high RPM use, prolonged low-speed heavy load operation, extended idle, and short trip cold weather operation.*

### INITIAL BREAK-IN SERVICE FIRST 25 HOURS / 1 MONTH

Air Filter	Inspect air filter; replace as necessary. Ensure proper installation of filter and airbox cover. Inspect ducts and screens; clean as necessary.
Cooling System	Fluid level inspection; inspect for fluid leaks; add coolant if needed. Inspect coolant strength seasonally; pressure test system yearly.
General Lubrication	Locate all applicable fittings and grease.
Shift Cable / Linkage	Inspect; adjust as needed
Parking Brake (if applicable)*	Inspect and adjust as needed.
Battery	Check terminals; terminals should be tight and free of corrosion. Clean, test, and replace as necessary.
Engine Oil and Filter	Change the engine oil and filter.
Front Gearcase Fluid	Initial fluid level inspection; inspect for fluid leaks; add lubricant if needed.
Transmission Fluid	Initial fluid level inspection; inspect for fluid leaks; add lubricant if needed.
Spark Arrestor	Clean out.
<p>The break-in period consists of the first 25 hours of operation. Careful treatment of a new engine and drive components will result in more efficient performance and longer life for these components. The items outlined in this service interval only need to be performed at the first 25 hours of operation. They do not need to be performed every 25 hours.</p>	
<p>* It is recommended to have an authorized Egimotors dealer perform these services.</p>	

## MAINTENANCE

---

*Tractors subjected to severe use must be serviced at 50% of the stated interval. Examples of Severe Use: Frequent immersion in mud, water, or sand, constant high RPM use, prolonged low-speed heavy load operation, extended idle, and short trip cold weather operation.*

### **EVERY 25 HOURS / (1800 KM) OR YEARLY FOLLOWING INITIAL BREAK-IN SERVICE**

Air Filter	Inspect air filter; replace as necessary. Ensure proper installation of filter and airbox cover. Inspect ducts and screens; clean as necessary.
Battery	Check terminals; terminals should be tight and free of corrosion. Clean, test, and replace as necessary.
Brake System	Fluid level inspection; inspect for fluid leaks; add lubricant if needed. Inspect brake pad wear.
General Lubrication	Locate all applicable fittings and grease.
Radiator	Inspect; Clean external surfaces.
Tires	Inspect; Adjust pressure level as needed; Inspect wear and replace as needed.
* Have an authorized Egimotors dealer or other qualified person perform these services.	

*Tractors subjected to severe use must be serviced at 50% of the stated interval. Examples of Severe Use: Frequent immersion in mud, water, or sand, constant high RPM use, prolonged low-speed heavy load operation, extended idle, and short trip cold weather operation.*

### EVERY 50 HOURS / (3200 KM) OR YEARLY FOLLOWING INITIAL BREAK-IN SERVICE

Air Filter	Inspect air filter; replace as necessary. Ensure proper installation of filter and airbox cover. Inspect ducts and screens; clean as necessary.
Battery	Check terminals; terminals should be tight and free of corrosion. Clean, test, and replace as necessary.
Brake System	Fluid level inspection; inspect for fluid leaks; add lubricant if needed. Inspect brake pad wear.
General Lubrication	Locate all applicable fittings and grease.
Radiator	Inspect; Clean external surfaces.
Tires	Inspect; Adjust pressure level as needed; Inspect wear and replace as needed.
Engine Oil and Filter	Change the engine oil and filter.
Spark Plug	Replace as needed.
Wiring	Inspect for wear, routing, and retention.
Front Gearcase Fluid	Change fluid.
Transmission Fluid	Change fluid.
Drive Belt	Inspect; replace as needed.
Spark Arrestor	Clean out.
Suspension Components / Alignment*	Inspect front and rear suspension bushings, and ball joints for loose or worn components; replace as needed. Inspect shock absorbers for leaks or damage.
Cooling System	Fluid level inspection; inspect for fluid leaks; add coolant if needed. Inspect coolant strength seasonally; pressure test system yearly.

## MAINTENANCE

### EVERY 50 HOURS / (3200 KM) OR YEARLY FOLLOWING INITIAL BREAK-IN SERVICE

Wheel Bearings	Inspect; replace as needed
Parking Brake (if applicable)*	Inspect and adjust as needed.
Fuel System*	Cycle key to pressurize fuel pump; check for leaks at fuel system connections, check for leaks at fill cap.
Throttle Body / Intake Ducts / Flanges	Inspect ducts for proper sealing / air leaks
Shift Cable / Linkage	Inspect; adjust as needed
Steering Components	Inspect; replace as needed.
* Have an authorized Egimotors dealer or other qualified person perform these services.	

*Tractors subjected to severe use must be serviced at 50% of the stated interval. Examples of Severe Use: Frequent immersion in mud, water, or sand, constant high RPM use, prolonged low-speed heavy load operation, extended idle, and short trip cold weather operation.*

### ADDITIONAL MAINTENANCE INTERVALS

<b>Every (3200KM) / 24 months / 2 years</b>	Brake Fluid	Change fluid.
	Clutches*	Inspect bushings, rollers, wearable parts; clean; replace worn parts.
<b>Every (4000KM)</b>	Shock Absorbers*	Inspect; replace or rebuild (if applicable).
<b>Every (6400KM)</b>	Valve Clearance*	Inspect; adjust as needed.
<b>Every (8900KM) / 60 months / 5 years</b>	Coolant	Change fluid.
* Have an authorized Egimotors dealer or other qualified person perform these services.		

## LUBRICATION RECOMMENDATIONS

Check and lubricate all components at the intervals outlined in the Periodic Maintenance Chart section, or more often under severe use, such as wet or dusty conditions. Items not listed in the chart should be lubricated at the general lubrication interval.

ITEM	LUBE	METHOD
Engine Oil	PS-4 5W-50 4-Cycle Oil and PS-4 Extreme 0W-50 4-Cycle Oil	
Brake Fluid	DOT 4 Brake Fluid	Maintain level between fill lines.
Transmission Oil (Main Gearcase)	AGL Gearcase Lubricant & Transmission Fluid	
Front Gearcase Fluid (Demand Drive)	Demand Drive Fluid	
Prop Shaft	Spline Grease	Grease the fitting until fresh grease is seen coming from the joint. Wipe away excess to prevent dirt/debris contamination.
Rear Stabilizer Bar Bushings	All Season Grease or grease conforming to NLGI No. 2	Remove engine access panel and grease 2 fittings (one on each side of Tractor).

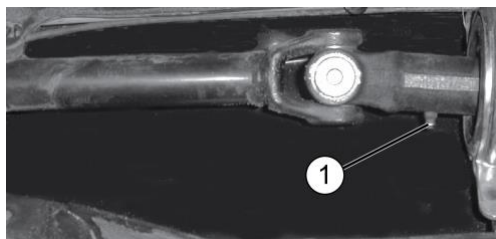

q Middle Prop Shaft Grease Fitting

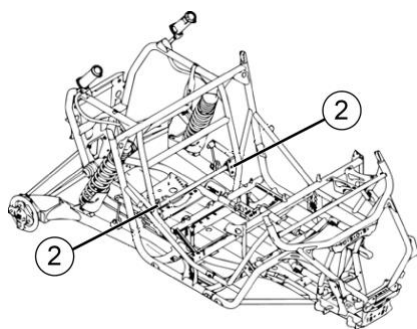

w Rear Stabilizer Bar Bushings (one on each side of Tractor)



## ENGINE OIL

### OIL RECOMMENDATIONS

#### WARNING

Tractor operation with insufficient, deteriorated, or contaminated engine oil will cause accelerated wear and may result in engine seizure, accident, and injury. Always perform the maintenance procedures as outlined in the Periodic Maintenance Chart.

Ambient Temperature Range	Recommended Oil
(-37 °C) to (+38 °C)	PS-4 5W-50 4-Cycle Oil
(-43 °C) to (+54 °C)	PS-4 Extreme 0W-50 4-Cycle Oil

Oil may need to be changed more frequently if POLARIS oil is not used. Do not use automotive oil. Follow the manufacturer's recommendations for ambient temperature operation.

#### NOTICE

Mixing brands or using a non-recommended oil may cause serious engine damage. Always use the recommended oil. Never substitute or mix oil brands.

Always check and change the oil at the intervals outlined in the Periodic Maintenance Chart. Always use the recommended engine oil.

# MAINTENANCE

---

## OIL CHECK

Always check the oil when the engine is cold and on a level surface. If the engine is hot when the oil is checked, the level will appear to be overfull.

Access the oil check dipstick **q** through the right rear wheel well. Access the oil fill cap **w** by removing the cargo box. See the Service Access Panels section for details.

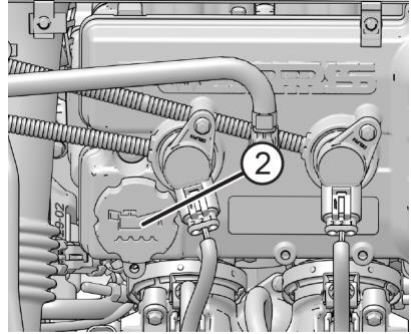
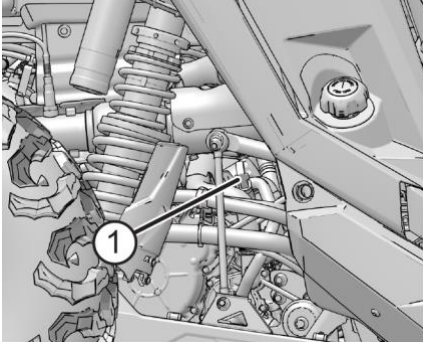

1. Position the Tractor on a level surface.
2. Place the transmission in PARK.
3. Start the engine. Allow the engine to idle for 30 seconds.
4. Stop the engine. Wait two (2) minutes to allow oil to drain back to the sump.
5. Remove the dipstick. Wipe it dry with a clean cloth.
6. Reinstall the dipstick completely. Remove the dipstick and check the oil level.
7. Remove the oil fill cap to add the recommended oil as needed. Maintain the oil level between the minimum and maximum marks on the dipstick. Do not overfill.
8. Reinstall the fill cap. Reinstall the dipstick.

## OIL AND FILTER CHANGE

### WARNING

Spilled oil left on engine components or in the engine area may pose a fire hazard. Use shop rags to clean any spilled oil. If needed, use a non-flammable solvent on the rag to aid the cleaning process. Do not use any device such as pressurized water or air as this may disperse the oil onto engine components and could pose a fire hazard.

Always change the oil and filter at the intervals outlined in the Periodic Maintenance Chart section.

1. Position the Tractor on a level surface. Place the transmission in PARK.
2. Allow engine to cool down before draining oil.
3. Place a drain pan under the engine crankcase and remove the drain plug (1).

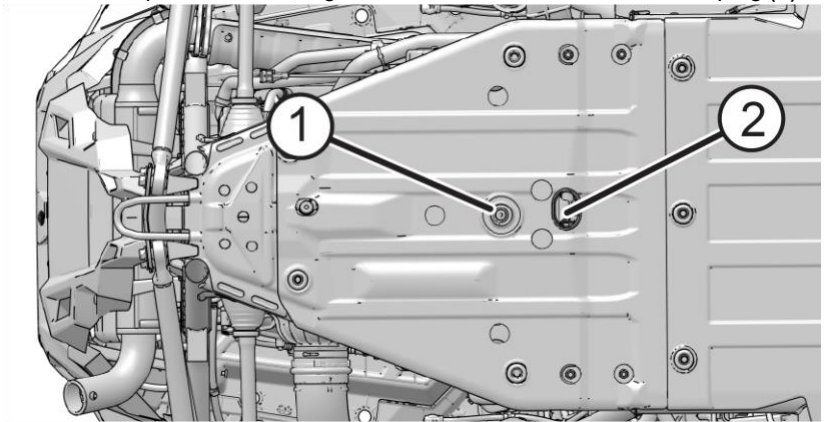

4. Access the oil filter through the access panel behind the seats. See the Service Access Panels section for details.

### NOTE

The engine should be off for at least 2 minutes prior to removing the oil filter.

5. Place drain pan under filter drain (2) to catch any spilled oil during removal. Using the Oil Filter Wrench, turn the oil filter counterclockwise to remove it. Tip the open end of the oil filter up to minimize oil spill.

## MAINTENANCE

---

6. Clean the filter sealing surface on the engine crankcase with a clean rag and ensure the original oil filter o-ring is not stuck to the crankcase.

### WARNING

Do not use a hose/pressure washer to clean up spilled oil on a Tractor. This may spread oil into surfaces that may get hot which may lead to a fire.

7. Lubricate the O-ring on the new oil filter with a film of clean engine oil. Check to make sure the O-ring is in good condition. Tighten to specification (Turn by hand until filter O-ring contacts sealing surface, then turn an additional 3/4 turn.)
8. Inspect the sealing washer on the drain plug for burrs or nicks. Replace the washer if it is damaged.
9. Reinstall the engine crankcase drain plug. Torque drain plug to specification (18 Nm)].
10. Remove the cargo box. See the Service Access Panels section for details. Add engine oil through the oil fill cap (3) located on top of the engine valve cover.

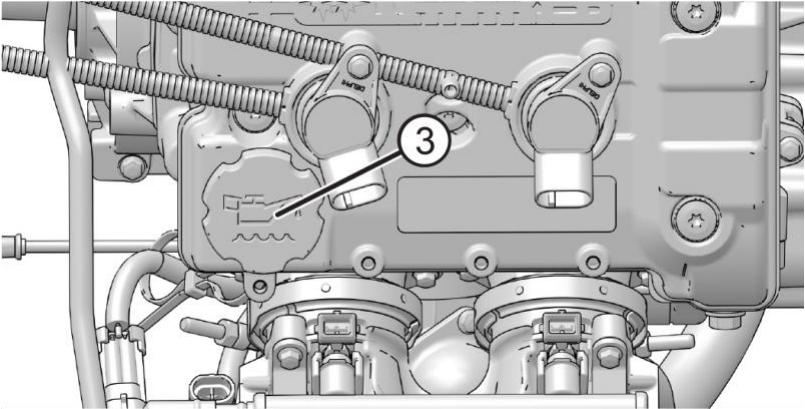

11. Fill the engine to the recommended specification.
12. Start engine and allow it to idle for 30 seconds.
13. Stop the engine and inspect for leaks. Wait at least 15 seconds before removing the oil dipstick.

14. Unlock the dipstick lever (4)r. Remove the dipstick and wipe it dry with a

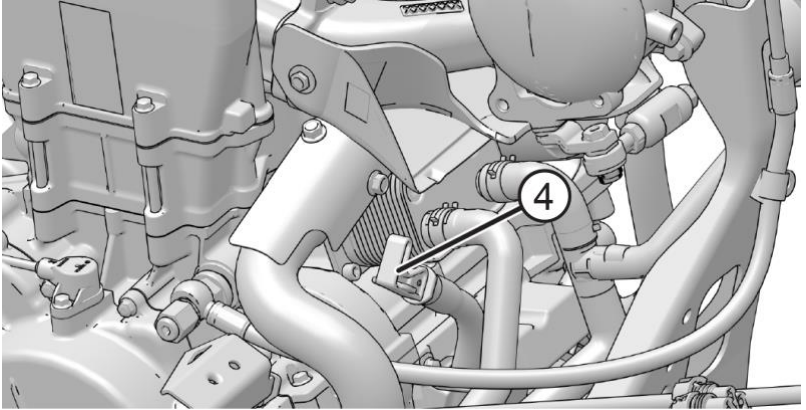

clean rag.

15. Reinstall the dipstick to fully seat it. Do not lock the dipstick.

### NOTE

Make certain the dipstick is inserted all the way down to ensure an accurate reading.

16. Remove the dipstick and check the oil level.
17. Add the recommended oil as necessary to bring the oil level within the SAFE range (between the holes) on the dipstick. Do NOT overfill.

### NOTE

A rising oil level between checks during cold weather operation can indicate contaminants such as gas or moisture collecting in the crankcase. If the oil level is over the upper mark, change the oil immediately.

18. When finished, reinstall dipstick and lock the lever.
19. Reinstall the cargo box.
20. Dispose of used oil, filter, and rags properly.

## MAINTENANCE

---

### TRANSMISSION (MAIN GEARCASE)

Always check and change the fluid at the intervals outlined in the Periodic Maintenance Chart section. Refer to the Gearcase Specifications Chart section for recommended lubricants, capacities and torque specifications.

#### FLUID CHECK

The fill plug (1) is located on the rear of the gearcase. Maintain the fluid level at the bottom of the fill plug hole.

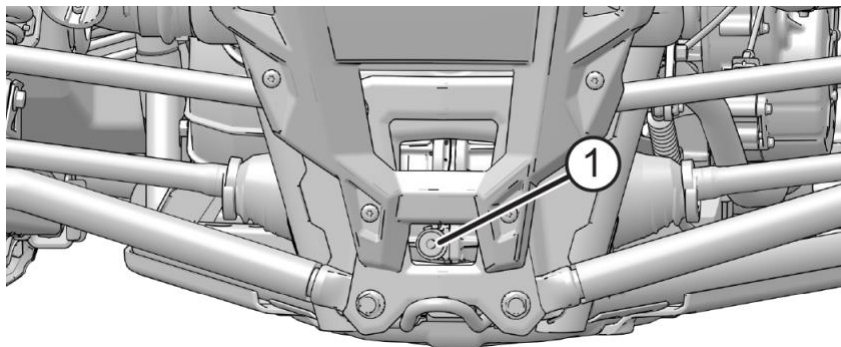

1. Position the Tractor on a level surface.
2. Remove the fill plug.
3. Check the fluid level.
4. Add the recommended fluid to the bottom of the fill plug hole. Do not overfill.
5. Reinstall the fill plug. Torque to specification.

## FLUID CHANGE

The drain plug (1) is located on the bottom of the gearcase. Access the drain plug through the drain hole in the skid plate.

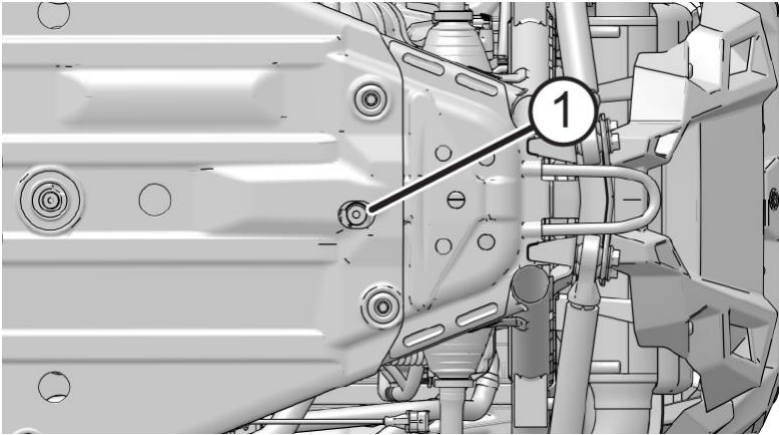

1. Remove the fill plug.
2. Place a drain pan under the drain plug.
3. Remove the drain plug. Allow the fluid to drain completely.
4. Clean the drain plug.
5. Reinstall the drain plug. Torque to specification (listed in the Gearcase Specification Chart of this manual).
6. Add the recommended fluid (listed in the Gearcase Specification Chart) to the bottom of the fill plug hole. Do not overfill.
7. Reinstall the fill plug. Torque to specification (listed in the Gearcase Specification Chart).
8. Check for leaks. Discard used fluid properly.

## MAINTENANCE

---

### DEMAND DRIVE UNIT (FRONT GEARCASE)

Always check and change the fluid at the intervals outlined in the Periodic Maintenance Chart section. Refer to the Gearcase Specifications Chart section for recommended lubricants, capacities and torque specifications.

Fill Plug Location

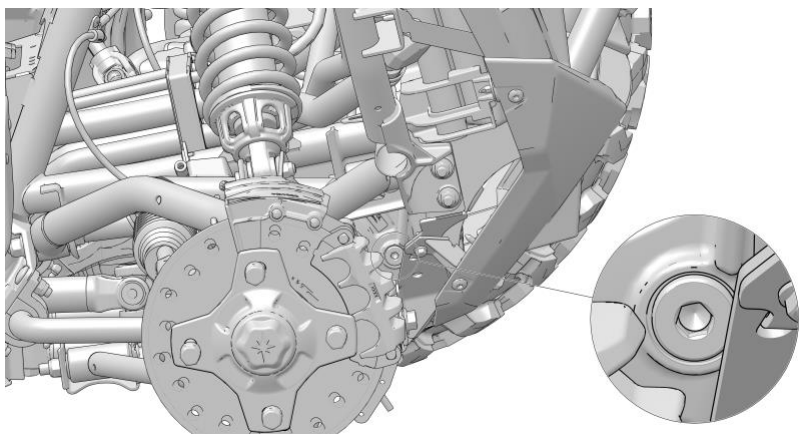

Drain Plug Location

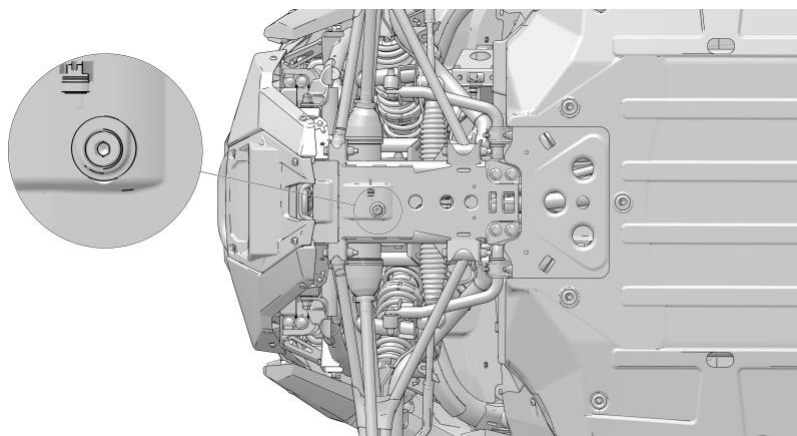



### DEMAND DRIVE FLUID CHECK

The fill plug is located on the bottom right side of the demand drive unit. Maintain recommended fluid volume (280 ml).

1. Position the Tractor on a level surface.
2. Remove the fill plug. Check the fluid level.
3. Add the recommended fluid to reach 280 ml capacity.
4. Reinstall the fill plug. Torque to specification.

### DEMAND DRIVE FLUID CHANGE

The demand drive drain plug w is located on the bottom of the gearcase.

1. Remove the fill plug.
2. Place a drain pan under the drain plug.
3. Remove the drain plug. Allow the fluid to drain completely.
4. Clean the drain plug.
5. Reinstall the drain plug. Torque to specification.
6. Add the recommended fluid (280 ml).
7. Reinstall the fill plug. Torque to specification.
8. Check for leaks. Discard used fluid properly and clean any excess oil residue.

## MAINTENANCE

---

### GEARCASE SPECIFICATION CHART

Use of other fluids may result in improper operation of components. See the Egimotors Products section for the part numbers.

<b>Gearcase</b>	<b>Lubricant</b>	<b>Capacity</b>	<b>Fill Plug Torque</b>	<b>Drain Plug Torque</b>
Transmission (Main Gearcase)	AGL Gearcase Lubricant & Transmission Fluid	(1800 ml)	(14-19 N·m)	(14-19 N·m)
Demand Drive Unit (Front Gearcase)	Demand Drive Fluid	(280 ml)	(11-14 N·m)	(11-14 N·m)

## SPARK PLUGS

### SPARK PLUG GAP / TORQUE

Electrode Gap	Spark Plug Torque
0.7-0.8 mm	(10 Nm)

#### NOTICE

Using non-recommended spark plugs can result in serious engine damage. Always use POLARISS-recommended spark plugs or their equivalent. Refer to the Specifications section for details.

Spark plug condition is indicative of engine operation. The spark plug firing end condition should be read after the engine is warmed up and the Tractor is driven at higher speeds. Immediately check the spark plug for correct color.

#### CAUTION

A hot exhaust system and engine can cause burns. Wear protective gloves when removing a spark plug for inspection.

## SPARK PLUG REMOVAL AND REPLACEMENT

1. Remove the cargo box to access the spark plugs (1).

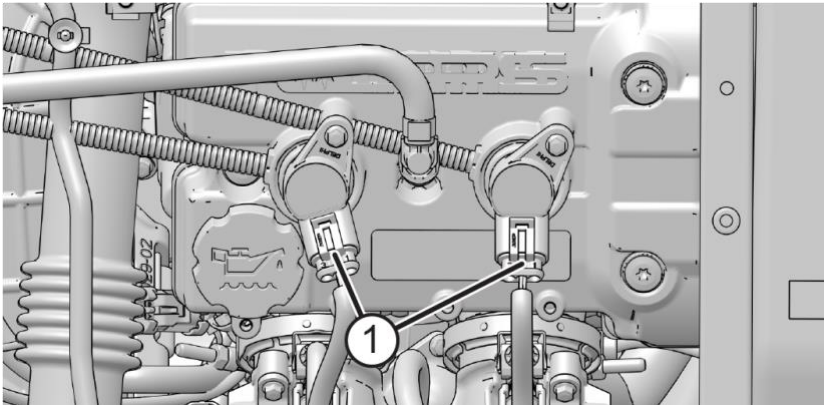

2. Clean the area around the spark plugs before removing the plugs. Unbolt the coils on the plugs.
3. Remove the coil assemblies.

## MAINTENANCE

---

4. Using the spark plug wrench provided in the tool kit, remove the plugs by rotating them counterclockwise.
5. Reverse the procedure for spark plug installation. Torque to specification.

### SPARK PLUG CONDITION

#### ***NORMAL PLUG***

The normal insulator tip is gray, tan or light brown. There will be few combustion deposits. The electrodes are not burned or eroded. This indicates the proper type and heat range for the engine and the service.

#### *NOTICE*

The tip should not be white. A white insulator tip indicates overheating, caused by use of an improper spark plug or incorrect throttle body adjustments.

#### ***WET FOULED PLUG***

The wet fouled insulator tip is black. A damp oil film covers the firing end. There may be a carbon layer over the entire nose. Generally, the electrodes are not worn. Fouling may be caused by excessive oil or by frequent short trips, especially in cold weather.

## FUSE / RELAY CENTER

**⚠ WARNING**

Do not arrange fuses improperly or use replacement fuses with improper amperage values. This could lead to electrical overload, which can result in severe injury or death.

If the engine stops or will not start, if the power steering stops working (if equipped), or if you experience other electrical failures, a fuse may need replacement. Locate and correct any short circuits that may have caused the blown fuse, then replace the fuse.

There are two fuse/relay centers accessible on the Tractor. The primary fuse center(1) is beneath the armrest and can be accessed by removing the bed of the armrest storage compartment.

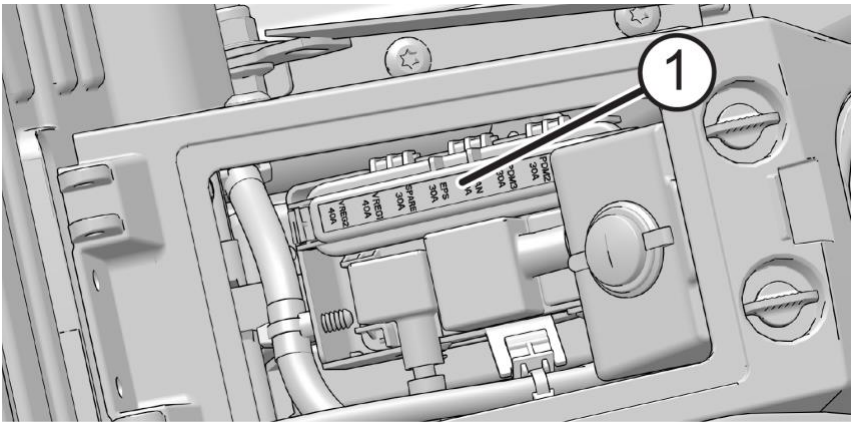

**PRIMARY FUSE CENTER**

LABEL	VALUE	FUNCTION
PDM 1	40A MCASE Fuse Fuse (30A MCASE Fuse for 2-seat Sport models only)	Power to Secondary Fuse Center for Lights, Instrumentation, and Accessory Relay
PDM 2	30A MCASE Fuse	Power to Secondary Fuse Center for Auxiliary Outlets, Chassis, SCM, and Shock Fuse

## MAINTENANCE

PRIMARY FUSE CENTER		
LABEL	VALUE	FUNCTION
PDM 3	30A MCASE Fuse	Power to Secondary Fuse Center for Fuel, LCAC, and EFI Fuse
FAN	30A MCASE Fuse	Engine Cooling Fan
EPS	30A MCASE Fuse	Electronic Power Steering
SPARE	30A MCASE Fuse	Spare fuse
VREG 1	40A MCASE Fuse	Voltage Regulator (Driver)
VREG 2	40A MCASE Fuse	Voltage Regulator (Passenger)
PULSE PWR	200A ZCASE Fuse	Battery Power to Egimotors Pulse and 6AWG Cable

The secondary fuse center (2) is under the dash, near the operator's right knee area.

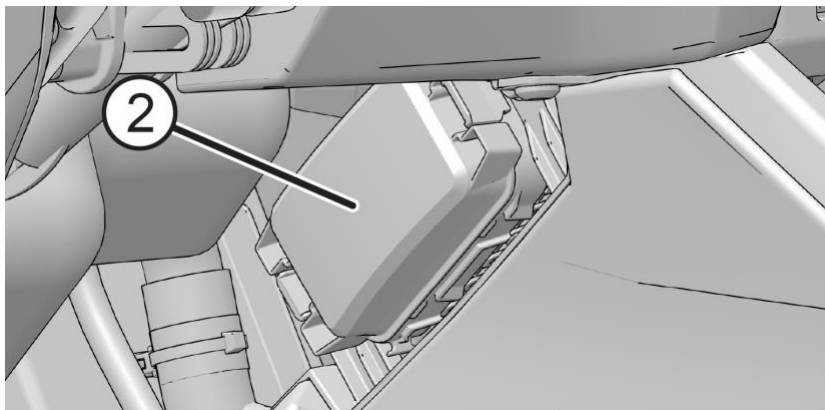

<b>SECONDARY FUSE CENTER</b>		
<b>LABEL</b>	<b>VALUE</b>	<b>FUNCTION</b>
LCAC	7.5A Fuse	Water Pump
FUEL	10A Fuse	Fuel Pump
TERM BLK	10A Fuse	Terminal Block Accessory
INST ACCY	5A Fuse	Diagnostic Accessory, Interior LED Light, Display Accessory (optional)
PWR PT 1	10A Fuse	12V Socket (in front of gear selector)
INST UNSW	7.5A Fuse	Display (optional), Gauge, Diagnostic
LIGHTS	7.5A Fuse	Headlights, Taillights, Accent Lights (optional), Brake Lights
CHASSIS	7.5A Fuse	AWD Switch Light, Oxygen Sensor Heater, EPS Wake-Up, Tractor Speed Sensor, Seat Belt Switch, SCM Wake-Up (optional), SCM Mode Switch (optional), AWD Coil, Gauge, Waste Gate
EFI	10A Fuse	Accessory Relay Coil, ECM Wake-Up, Pump Relay Coil, Chassis Relay Coil, Start Relay Coil, EFI Relay Coil, Injectors, SCM Relay Coil (optional), Lights Relay Coil, Ignition Coil, Starter Solenoid Coil, Brake Relay Coil
COIL	7.5A Fuse	Coil on Plug
<b>DYNAMIX Models</b>		
SCM	5A Fuse	Shock Control Module
SHOCK	5A Fuse	Shock Power
AMP*	30A Fuse	Audio Amplifier
SUB*	40A Fuse	Audio Subwoofer

## MAINTENANCE

---

\*For Tractors equipped with audio amplifiers and subwoofers, the fuses are located underneath the front storage compartment above the center console. Open the storage compartment and unlatch the four clips holding the storage tray in place to access the fuses (3).

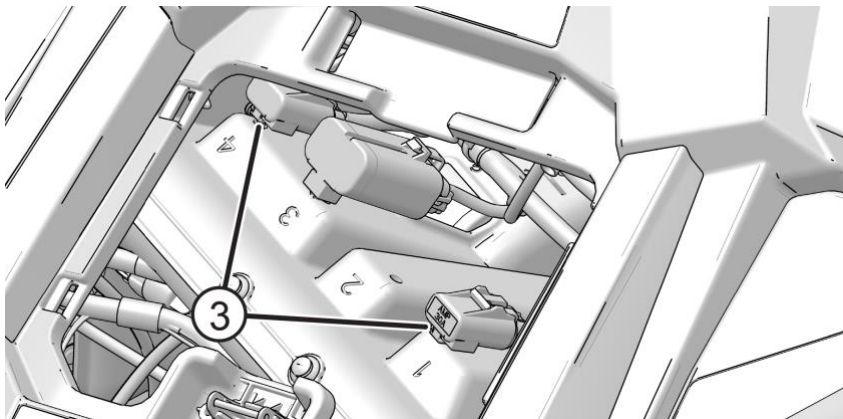



---

## COOLING SYSTEM

 **CAUTION**

Escaping steam can cause burns. Never remove the pressure cap while the engine is warm or hot. Always allow the engine to cool before removing the pressure cap.

The engine coolant level is maintained by a remote pressurized tank system. The remote pressurized tank is connected to both radiators and provides a single pressure cap and fill point for the Tractor.

**NOTICE**

The cooling system can cause audible liquid flowing noises as the Tractor cools down after operation. This is considered normal for the Tractor.

The pressure tank is designed to contain a volume of air above the coolant level. As coolant operating temperature increases the coolant level in the pressure tank will rise and push out air past the pressure cap. As the engine coolant temperature decreases the coolant level in the pressure tank will lower and draw air back into the tank through the pressure cap.

**NOTICE**

Some coolant level drop on new Tractors is normal as the system is purging itself of trapped air. Observe coolant levels and maintain cold coolant level as recommended by adding coolant to the pressure tank.

## MAINTENANCE

### RADIATOR COOLANT LEVEL / CHANGING COOLANT

The changing coolant procedure is required only if the cooling system has been drained for maintenance and/or repair. Ensure Tractor is parked on a level surface before servicing.

#### CAUTION

Escaping steam can cause burns. Never remove the pressure cap while the engine is warm or hot. Always allow the engine to cool before removing the pressure cap.

1. If only needing to check coolant level, there is a view (1) from driver's side rear fender. A flashlight may be needed. The coolant level can also be viewed by removing the cargo box.

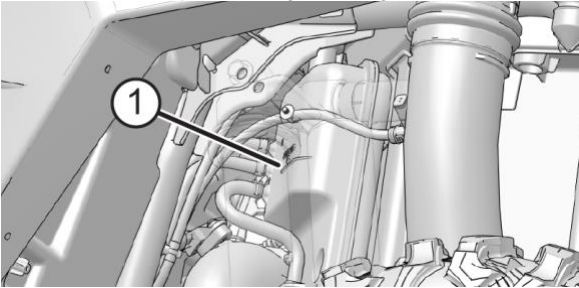

#### TIP

Ensure engine has cooled off prior to checking.

2. To add coolant, begin by removing bottle access cover (2) in rear of Tractor.

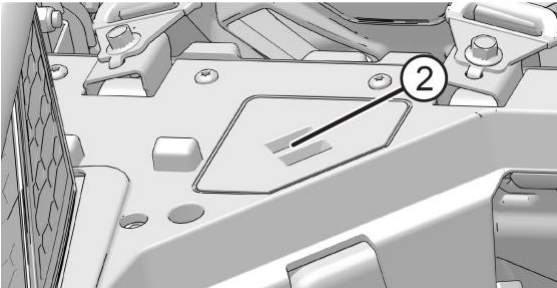

3. Slowly remove the radiator pressure cap (3).

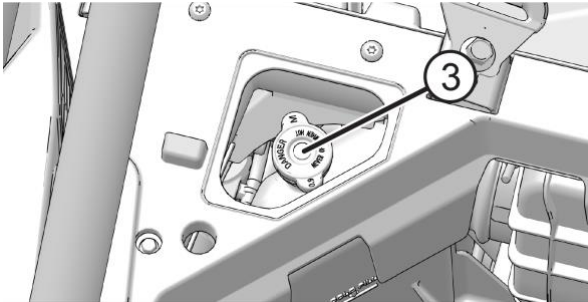

4. Remove the pressure cap and use a funnel to add coolant as needed. Maintain the coolant level within (2.5 cm) of the cold fill mark on the side of the pressure tank (only when the fluid has cooled, if after operation).
5. Reinstall the pressure cap and the bottle access cover.

### TIP

Use of a non-standard pressure cap will not allow the recovery system to function properly. Your authorized dealer can provide the correct replacement part.

### TIP

If coolant must be added often, or if the pressure tank runs completely dry, there may be a leak in the system. Your authorized dealer can inspect the cooling system.

## MAINTENANCE

---

### ADDING OR CHANGING COOLANT

EGIMOTORS recommends the use of POLARIS Antifreeze 50/50 Premix. This antifreeze is already premixed and ready to use. Do not dilute with water. See the Egimotors Products section for the part numbers.

To ensure that the coolant maintains its ability to protect the engine, we recommend that the system be completely drained every five (5) years and fresh Antifreeze 50/50 Premix added.

Any time the cooling system has been drained for maintenance or repair, replace the coolant with fresh Antifreeze 50/50 Premix.

### RADIATORS AND COOLING FAN

Always check and clean the screens and radiator fins at the intervals outlined in the Periodic Maintenance Chart section. Do not obstruct or deflect air flow through the radiators by installing unauthorized accessories in front of the radiators or behind the cooling fan. Interference with radiator air flow can lead to overheating and consequent engine damage.

#### NOTICE

Washing the Tractor with a high-pressure hose could damage radiator fins and impair a radiator's effectiveness. Using a high-pressure system is not recommended.

## POLARIS VARIABLE TRANSMISSION (PVT) SYSTEM

### WARNING

Failure to comply with the instructions in this warning can result in severe injury or death.

Do not modify any component of the PVT system. Doing so may reduce its strength so that a failure may occur at a high speed. The PVT system has been precision balanced. Any modification will cause the system to be out of balance, creating vibration and additional loads on components.

The PVT system rotates at high speeds, creating large amounts of force on clutch components. As the owner, you have the following responsibilities for your own safety and the safety of others:

- Always follow all recommended maintenance procedures. Always look for and remove debris inside and around the clutch and vent system when replacing the belt.
- See your dealer or other qualified service person as recommended in the owner's manual and on safety labels.
- This PVT system is intended for use on EGIMOTORS products only. Do not install it in any other product.
- Always make sure the PVT housing is securely in place during operation.

Belt slip is responsible for creating excessive heat that destroys belts, wears clutch components and causes outer clutch covers to fail. Switch to low range while operating at slower speeds to extend the life of the PVT components (belt, cover, etc.).

## MAINTENANCE

### BELT REPLACEMENT / DEBRIS REMOVAL

If a belt fails, always clean any debris from the outlet duct and from the clutch and engine compartments when replacing the belt.

#### WARNING

Failure to remove ALL debris when replacing the belt could result in Tractor damage, loss of control and severe injury or death.

1. Allow hot components to cool before performing this procedure.
2. Remove the engine access panel and thoroughly clean ALL debris from the engine compartment.

#### NOTE

If the Tractor is on solid ground, removal of the left rear wheel or shock is not necessary for belt replacement. If the Tractor is on a lift, the shock must be removed in order to remove the clutch cover.

3. Loosen the clamp 1 retaining the PVT inlet duct to the outer clutch cover.
4. Remove the fourteen (14) clutch cover screws 2.

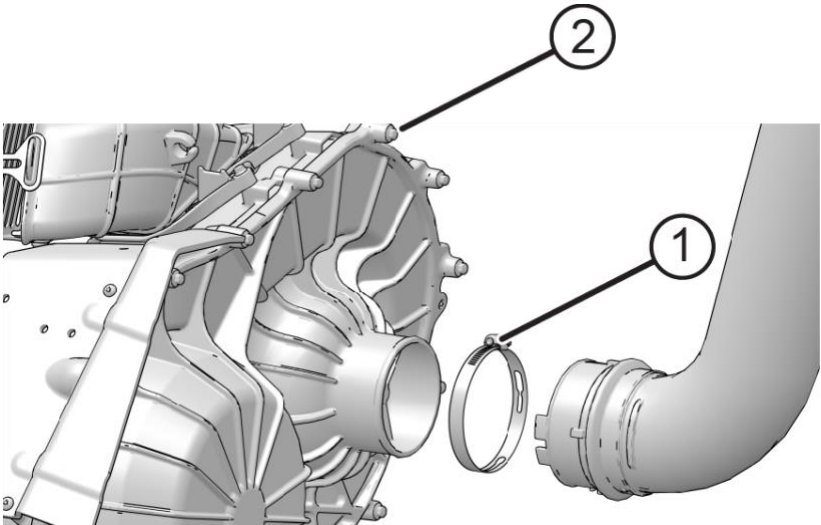

5. Maneuver the outer clutch cover outward to access the drive belt.
6. Mark the drive belt direction of rotation so that it can be installed in the same direction.

7. Insert the clutch spreader tool 3 into the driven clutch. The tool is provided in the tool kit.

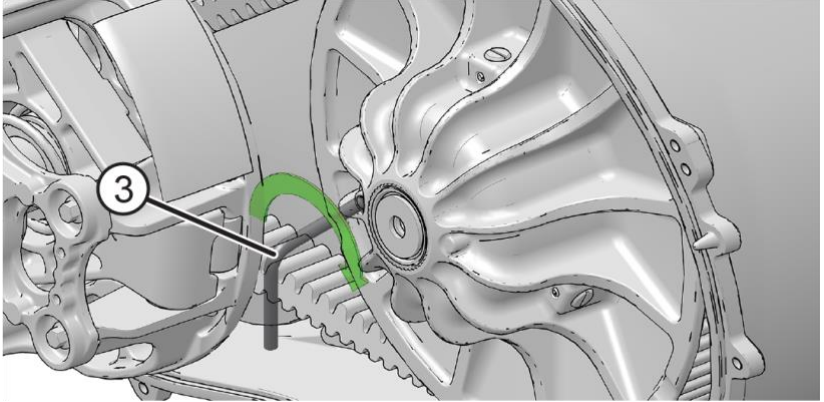

8. Turn the tool clockwise to open the sheaves on the driven clutch.
9. Walk the belt out of the driven and drive clutch. Remove the belt.
10. Remove **ALL** debris wrapped in and around the PVT system.
11. Remove **ALL** debris from the entire clutch air duct passage.
12. Check for signs of damage to seals on the transmission and engine. If any seals appear to be damaged, your Tractor requires prompt service. Your EGIMOTORS dealer can assist.

### TIP

Belt slip is responsible for creating excessive heat that destroys belts, wears clutch components and causes outer clutch covers to fail. Switch to low range while operating at slower speeds to extend the life of the PVT components (belt, cover, etc.). Prolonged operation with heavy loads or at high speeds can shorten belt life.

## MAINTENANCE

---

### PVT DRYING

There may be some instances when water is accidentally ingested into the PVT system. Use the following instructions to dry it out before operating.

#### NOTICE

When washing the Tractor, always avoid spraying water directly toward the PVT intake duct. See the Washing the Tractor section for details.

1. Remove the clutch cover drain plug.
2. Allow the water to drain. Reinstall the drain plug.
3. Place the transmission in PARK. Apply the brakes.
4. Start the engine.
5. Apply varying throttle for 10-15 seconds to expel the moisture and air-dry the belt and clutches. Do not hold the throttle wide open for more than 10 seconds.
6. Allow the engine RPM to settle to idle speed. Apply the brakes. Shift the transmission to the lowest available range.
7. Test for belt slippage. If the belt slips, repeat the process.
8. Your Tractor requires service as soon as possible. Your EGIMOTORS dealer or authorized person can assist.



## FILTER SYSTEMS

### INTAKE PRE-FILTERS

The clutch air intake (1) is located on the left side of the Tractor. The engine intake pre-filter (2) is located on the right side of the Tractor.

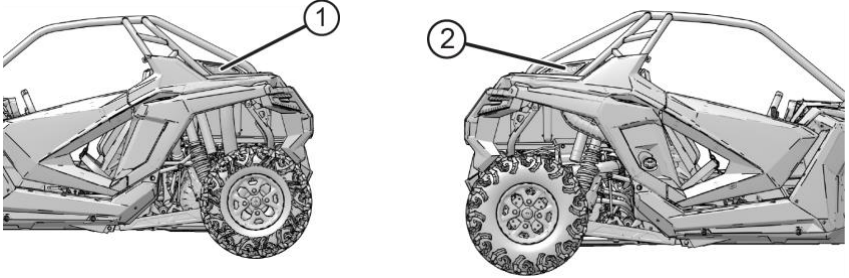

Inspect the engine pre-filter before each use of the Tractor to ensure adequate air flow. If necessary, remove the pre-filter and clean with soapy water. Dry with low pressure compressed air.

Periodically inspect the clutch (PVT) air intake for debris and clean as needed to ensure adequate air flow.

#### TIP

When washing the Tractor, always avoid spraying water directly toward the PVT intake. If water is sprayed into the PVT intake, follow the procedures in the PVT Drying section. See the Washing the Tractor section for recommended washing procedures.

# MAINTENANCE

## AIR FILTER

### WARNING

Be sure to replace all Tractor components as before once finished servicing the air filter. Improper thermal protection creates a fire hazard and can lead to injury or death.

Always change the air filter at the intervals outlined in the Periodic Maintenance Chart.

1. Remove the close-off panel between the seats.
2. Clean all dirt and debris from the air box area.
3. Unlatch the five (5) air box cover clips 1 and carefully remove the air box cover.

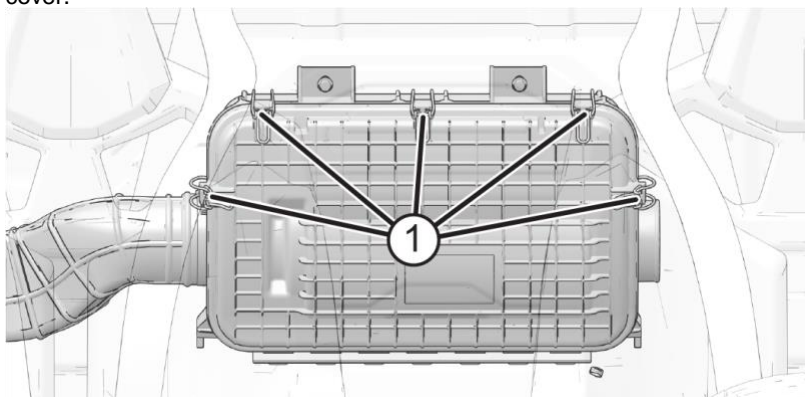

4. Inspect the air filter 2 and air box for dirt, debris or water.

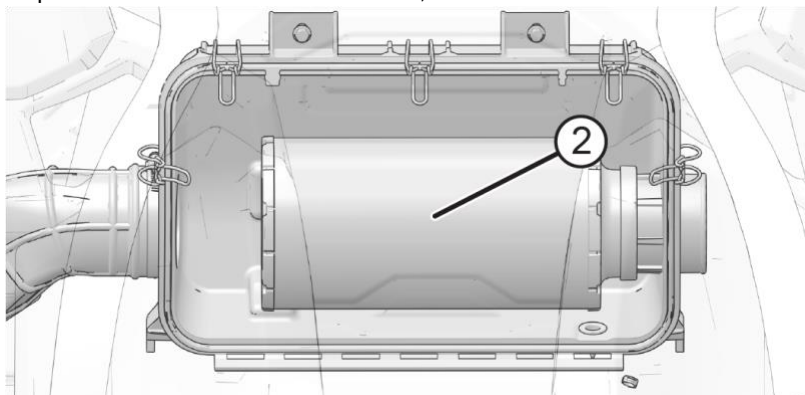

5. To remove the filter, slide the filter toward the passenger's side of the Tractor.
6. With the filter removed, clean the intake tube and air box thoroughly. Wipe well with a clean, dry cloth.

### NOTICE

Dirt or debris in the intake tube could result in severe engine damage. Always clean all dirt and debris from the intake tube before installing the filter.

7. Reinstall the air filter (if clean) or install a new air filter (if soiled). Do not attempt to clean the air filter.

### NOTICE

Use of a non-POLARIS-approved air filter may cause engine damage. Always use a POLARIS-approved replacement filter. Replacement filters are available at your EGIMOTORS dealer.

8. Make sure that there are no gaps between the filter, the filter ring and the stop on the intake tube.
9. Reinstall the air box cover and ensure the alignment tabs are properly positioned.
10. Secure the five (5) cover clips.
11. Reinstall the close-off panel.

## SPARK ARRESTER

### WARNING

- Never operate the Tractor without the spark arrester.
- Remove any combustible materials from the area.

**Failure to heed the following warnings while servicing the spark arrester could result in serious injury or death.**

- Never run the engine in an enclosed area. Exhaust contains poisonous carbon monoxide gas that can cause loss of consciousness or death in a very short time.
- Do NOT perform service on the spark arrester while the system is HOT. Exhaust system temperatures can reach extreme temperatures. Allow components to cool sufficiently before proceeding.
- Do not stand behind or in front of the Tractor while purging the exhaust system.
- Never go under the Tractor while it is inclined.
- Wear eye protection and gloves while servicing.

## MAINTENANCE

---

Periodically clean the spark arrester to remove accumulated carbon. A plugged spark arrester will affect engine performance. Clean daily when driving in mud and water. Replace a cracked or damaged arrester before operating.

1. Remove the arrester retaining bolt (1) and nut (2).
2. Remove the arrester from the end of the muffler (3).
3. Use a non-synthetic brush to clean the arrester screen. A synthetic brush may melt if components are warm. If necessary, blow debris from the screen with compressed air.

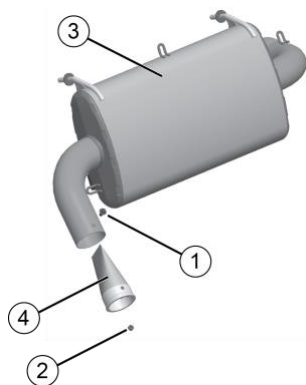

4. Inspect the screen for wear and damage. Replace a worn or damaged screen.
5. Reinstall the arrester. Torque bolt to (9-12 Nm).

---

## BRAKES

 **WARNING**

Operating the Tractor with a spongy brake pedal can result in loss of braking, which could cause an accident resulting in severe injury or death. Never operate the Tractor with a spongy-feeling brake pedal.

The front and rear brakes are hydraulic disc type brakes activated by the brake pedal.

 **CAUTION**

Brake discs can become extremely hot after operation. Allow the discs to cool before performing maintenance to prevent risk of burns.

Always check brake pedal travel and the brake fluid reservoir level before each use of the Tractor. When applied, the brake pedal should feel firm. Any sponginess would indicate a possible fluid leak or low brake fluid level, which must be corrected before riding. See the Brake Fluid section for further details.

If you discover any irregularities in brake system operation, including excessive pedal travel, contact your dealer for proper diagnosis and repairs.

## MAINTENANCE

### BRAKE INSPECTION

#### WARNING

Do not apply WD-40® or any petroleum product to brake discs. These types of products are flammable and may also reduce the friction between the brake pad and caliper.

1. Check the brake system for fluid leaks.
2. Check the brake pedal for excessive travel or a spongy feel.
3. Check the friction pads for wear, damage and looseness.
4. Check brake discs for signs of cracks, excessive corrosion, warping or other damage. Clean any grease using an approved brake cleaner or alcohol.
5. Inspect the brake disc spline and pad wear surface for excessive wear. Change pads when worn to 4.6 mm (1).

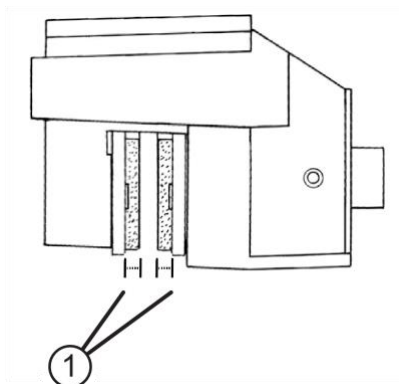

## BRAKE FLUID

**⚠ WARNING**

After opening a bottle of brake fluid, always discard any unused portion. Never store or use a partial bottle. Brake fluid is hygroscopic, meaning it rapidly absorbs moisture from the air. The moisture causes the boiling temperature of the brake fluid to drop, which can lead to early brake fade and the possibility of accident or severe injury.

Inspect the level of the brake fluid before each operation. If the fluid level is low add DOT 4 brake fluid only. See the Egimotors Products section for the part numbers.

Change the brake fluid every two years and any time the fluid becomes contaminated, the fluid level is below the minimum, or if the type and brand of the fluid in the reservoir are unknown. Access the brake fluid reservoir through the left front wheel well.

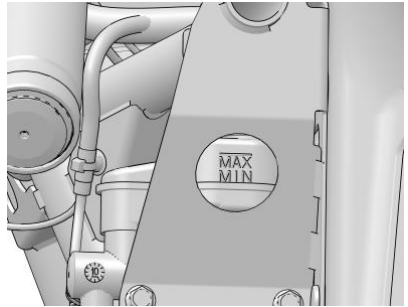

1. Position the Tractor on a level surface.
2. Place the transmission in PARK.
3. View the brake fluid level in the reservoir, located in the front driver-side wheel well. The level should be between the maximum and minimum level lines.
4. If the fluid level is lower than the lower level line, add brake fluid to the upper line.

**⚠ WARNING**

Do not overfill the brake system reservoir. Overfilling can cause pressure build-up leading to brake drag, system degradation, and brake system failure.

5. Apply the brake forcefully for a few seconds and check for fluid leakage around the fittings.

### SUSPENSION SYSTEM

#### FRONT / REAR SHOCK COMPRESSION ADJUSTMENT (IF APPLICABLE)

 **WARNING**

Be advised that the shocks contain nitrogen at high pressure. Damaged shocks could cause injury if not replaced or addressed promptly by qualified personnel.

 **CAUTION**

Keep other individuals away from the Tractor when adjusting the shocks. Boarding the Tractor creates sudden shock compression, which can cause pinched fingers during maintenance.

The compression damping clicker knob is located at the top of the shock reservoir. When the knob is turned fully clockwise, the damping is in the fully closed position.

1. Turn the clicker clockwise to increase compression damping.
2. Turn the clicker counterclockwise to decrease compression damping.

SETTING	COMPRESSION DAMPING
Softest	Position 1
Factory	Position 2
Firmer	Position 3



## FRONT / REAR SPRING PRELOAD ADJUSTMENT

The factory setting is appropriate for nearly all riding conditions. If desired, the suspension may be adjusted to maintain Tractor clearance height when carrying loads. Adjusting the suspension may change Tractor handling.

### IMPORTANT

The distance between the main preload ring (top ring) and the cross-over rings (middle rings) should be constant. If you move the main preload ring, you will need to move the cross-over rings an equal amount. The cross-over rings need to be locked tight after any adjustment is made. To lock the cross-over rings, take a punch and hammer to hit each side so the rings jam together. If the cross-over rings are not locked down tight, damage to the shock may occur.

To adjust the preload, do the following:

1. Elevate the Tractor to allow the suspension to fully extend.
2. Turn the adjusting ring to the left to add preload. Turn the adjusting ring to the right to remove preload.

Uneven adjustment may cause poor handling of the Tractor. Always adjust both the left and right spring preloads equally or have your EGIMOTORS dealer or qualified person perform the adjustments.

### SPRING PRELOAD ADJUSTMENTS

#### RZR PRO XP 4

If weight is added to the center of the unit, split the preload setting accordingly between the front and the rear

(13 mm) per  
(45.4 kg) added to  
**front**

**MAX:** (25 mm)

(13 mm) per  
(45.4 kg) added to **rear**

**MAX:** (25 mm)

## MAINTENANCE

### PRELOAD SETTINGS

Adjusting preload settings can alter Tractor handling.

#### IMPORTANT

Never exceed the MAX allowable preload when adjusting the suspension. Damage to the suspension system may occur if the MAX allowable preload is exceeded.

RZR PRO XP 4		FACTORY DEFAULT PRELOAD SETTINGS	
	Measurements*	Fox® Dynamix	Fox® QS3®
Front Shocks	(1)	(5.08 cm)	(2.06 cm)
	(2)	(7.32 cm)	(7.14 cm)
Rear Shocks	(1)	(15.90 cm)	(14.94 cm)
	(2)	(17.14 cm)	(19.20 cm)

\*See the images in the Front / Rear Spring Preload Adjustment section to view corresponding measurements

**FOX® DYNAMIX SHOCKS (IF EQUIPPED)**

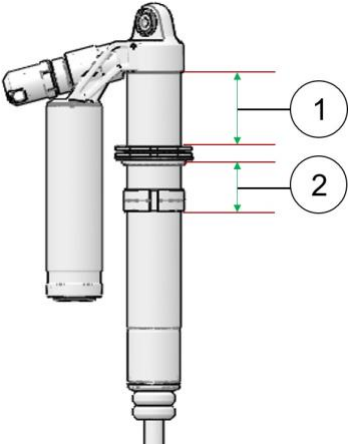
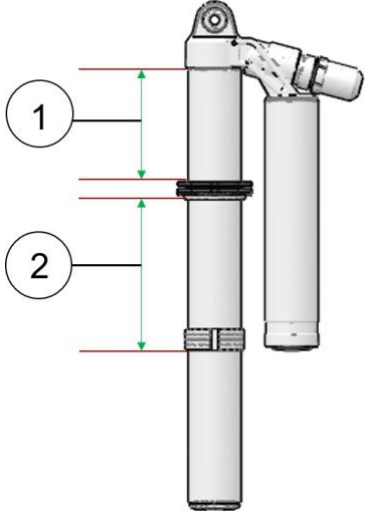
SHOCK LOCATION	MEASUREMENT*
Front Shock	 <p>The diagram shows a front FOX Dynamix shock. Two measurement points are indicated with green double-headed arrows and red horizontal lines. Measurement 1 is the distance from the top of the shock body to the top of the lower cartridge. Measurement 2 is the distance from the top of the lower cartridge to the top of the lower springer.</p>
Rear Shock	 <p>The diagram shows a rear FOX Dynamix shock. Two measurement points are indicated with green double-headed arrows and red horizontal lines. Measurement 1 is the distance from the top of the shock body to the top of the lower cartridge. Measurement 2 is the distance from the top of the lower cartridge to the top of the lower springer.</p>

# MAINTENANCE

## FOX® QS3® SHOCKS (IF EQUIPPED)

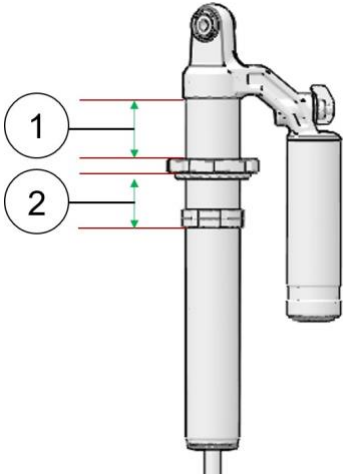
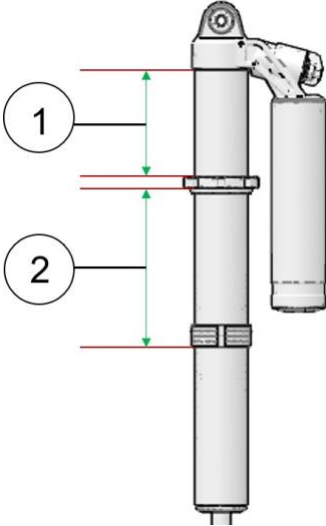
SHOCK LOCATION	MEASUREMENT*
Front Shock	 <p>The diagram shows a front shock absorber assembly. Two measurement points are indicated with green double-headed arrows and red horizontal lines. Point 1 is the distance between the top mounting eye and the upper seal. Point 2 is the distance between the upper seal and the lower seal. A separate cylindrical component, likely a reservoir or seal, is shown to the right of the main assembly.</p>
Rear Shock	 <p>The diagram shows a rear shock absorber assembly. Two measurement points are indicated with green double-headed arrows and red horizontal lines. Point 1 is the distance between the top mounting eye and the upper seal. Point 2 is the distance between the upper seal and the lower seal. A separate cylindrical component, likely a reservoir or seal, is shown to the right of the main assembly.</p>

## TIRES

### WARNING

Operating your Tractor with worn tires will increase the possibility of skidding, loss of control and an accident, which could result in serious injury or death. Always replace tires when the tread depth measures 1/8 in (3 mm) or less.

Improper tire inflation or the use of non-standard size or type of tires may adversely affect Tractor handling, which could result in Tractor damage or personal injury. Always maintain proper tire pressure. Always use EGIMOTORS- approved size and type of tires for this Tractor when replacing tires.

Tires age even if they have not been used or have only been used occasionally. Cracking of the tread and sidewall rubber and/or deformation is evidence of aging. Tires should be inspected for aging before use. If signs of aging or damage are found, see your Egimotors dealer or other qualified

### TIRE TREAD DEPTH

Always replace tires when tread depth is worn to 3 mm (1) or less.

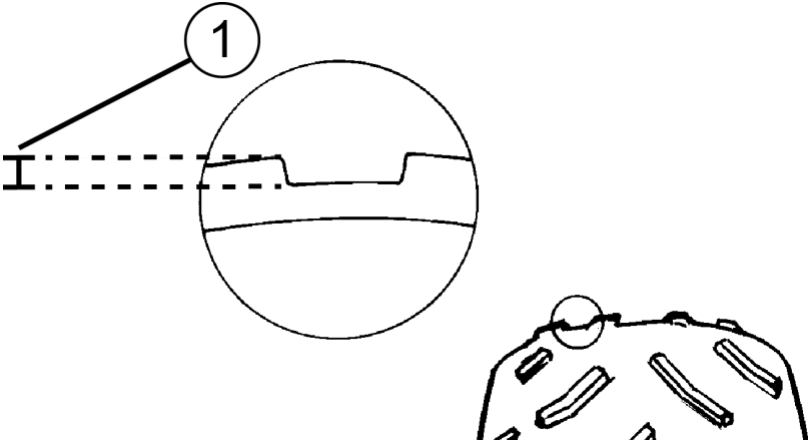

## MAINTENANCE

---

### TIRE ROTATION

Tire rotation is recommended for every (800-km) interval. Perform tire rotation on the Tractor by the strategy as shown.



### AXLE AND WHEEL NUT TORQUE SPECIFICATIONS

Inspect the following items occasionally for tightness, and if they've been loosened for maintenance service. *Do not lubricate the stud or the lug nut.*

Lug Nut (Aluminum Wheels)	Front and Rear	(182.7 Nm)
Hub Retaining Nut	Front and Rear	(244 Nm)

### WHEEL REMOVAL

1. Position the Tractor on a level surface.
2. Place the transmission in PARK.
3. Stop the engine.
4. Loosen the wheel nuts slightly.
5. Elevate the side of the Tractor by placing a suitable stand under the frame.
6. Remove the wheel lug nuts. Remove the wheel.

## WHEEL INSTALLATION

### WARNING

Improperly installed wheels can adversely affect tire wear and Tractor handling, which can result in serious injury or death. Always ensure that all nuts are torqued to specification. Do not service axle nuts that have a cotter pin installed. Your EGIMOTORS dealer or other qualified person can assist.

1. Place the transmission in PARK.
2. Place the wheel in the correct position on the wheel hub. Be sure the valve stem  $q$  is toward the outside and rotation arrows on the tire point toward forward rotation.
3. Attach the wheel nuts and finger tighten.
4. Carefully lower the Tractor to the ground.
5. Torque the wheel nuts to specification. See the Axle and Wheel Nut Torque Specifications section for details.

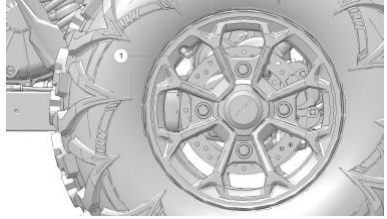

Right Rear Wheel  
(type varies by model)

## MAINTENANCE

---

### LIGHTS

Headlight and taillight lenses become dirty during normal operation. Clean all lights frequently to ensure a clear field of vision as well as visibility to other Tractors.

#### TIP

##### LED LAMPS

If an LED headlamp appears to have moisture or fogging *inside* the lens, disconnect the wiring harness from the headlamp(s) for a few days to allow the moisture to clear out.

#### TIP

##### HALOGEN LAMPS

When servicing a halogen lamp, don't touch the lamp with bare fingers. Oil from your skin leaves a residue, causing a hot spot that will shorten the life of the lamp.

### TAILLIGHT / BRAKE LIGHT REPLACEMENT

The taillight assembly is not serviceable. If the taillight or brake light fails to operate properly, replace the entire taillight assembly.

### HEADLIGHT REPLACEMENT

If a headlight becomes damaged or inoperable, the entire headlight assembly must be replaced. Do not operate this Tractor at night or in low light conditions until the headlight is replaced. Always make sure lights are adjusted properly for best visibility.



## HEADLIGHT BEAM ADJUSTMENT

The headlight beam can be adjusted slightly upward or downward and to the left or right.

1. Position the Tractor on a level surface. The headlight should be approximately 25 ft. (7.6 m) from a wall.

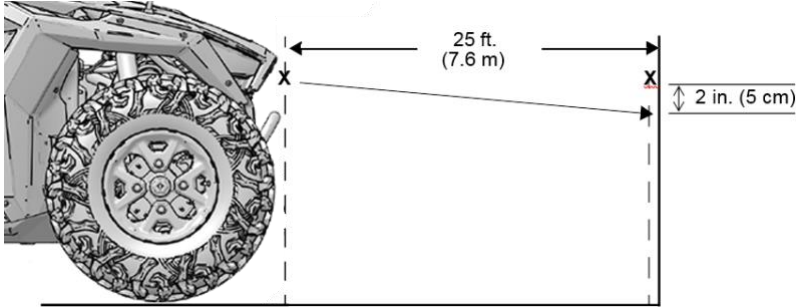

2. Place the transmission in PARK.
3. Measure the distance from the floor to the center of the headlight and make a mark on the wall at the same height.
4. Apply the brakes. Start the engine. Turn the headlights to high beam.
5. Include the weight of a rider on the seat while performing this step. Observe the headlight aim. As a starting point, the most intense part of the headlight beam should be 2 inches (5 cm) below the mark on the wall. Adjust to operator preference.
6. Tighten or loosen the two (2) headlight screws q to adjust the beam upward or downward or to the left or right.

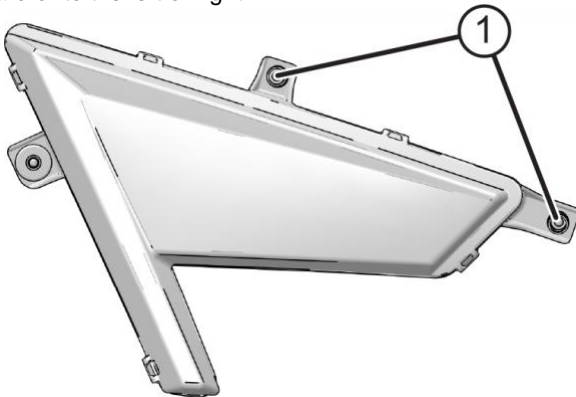

### TRACTOR IMMERSION

#### NOTICE

If your Tractor becomes immersed, major engine damage can result if the machine is not thoroughly inspected. Take the Tractor in for service before starting the engine. Your EGIMOTORS dealer can provide this service.

If it's impossible to take your Tractor to a dealer before starting it, follow the steps outlined below.

1. Move the Tractor to dry land.
2. Check the air box. See the Air Filter section for details. If water is present, dry the air box and replace the filter with a new filter.
3. Remove the fuse/relay center cover. See the Fuse/Relay Center section for details. Allow any moisture to dry, then reinstall the cover.
4. Dry the spark plug wells with a clean cloth, then remove the spark plugs.
5. Turn the engine over several times to expel any water from the engine cylinders.
6. Dry the spark plugs and reinstall them or install new plugs.
7. Attempt to start the engine. If necessary, repeat the drying procedure.
8. Take the Tractor in for service as soon as possible, whether you succeed in starting it or not. Your EGIMOTORS dealer can provide the required service.
9. If water has been ingested into the PVT follow the steps in the EGIMOTORS Variable Transmission (PVT) System section for drying procedures.

### STEERING WHEEL INSPECTION

Check the steering wheel for specified free play and smooth operation at the intervals outlined in the Periodic Maintenance Chart.

1. Position the Tractor on level ground.
2. Lightly turn the steering wheel left and right.
3. There should be (20-25 mm) of free play.
4. If there is excessive free play or strange noises, or if the steering feels rough or "catchy," have the steering system inspected by an authorized EGIMOTORS dealer or other qualified personnel.

## BATTERY

### WARNING

Improperly connecting or disconnecting battery cables can result in an explosion and cause serious injury or death. When removing the battery, always disconnect the negative (black) cable first. When reinstalling the battery, always connect the negative (black) cable last.

Your Tractor has a low-maintenance battery. Always keep battery terminals and connections free of corrosion. If cleaning is necessary, remove the corrosion with a stiff wire brush. Wash with a solution of one tablespoon baking soda and one cup water. Rinse well with tap water and dry off with clean shop towels. Coat the terminals with dielectric grease or petroleum jelly.

### NOTE

If more amperage is required for high electrical loads, an additional battery can be added.

## BATTERY REMOVAL

1. Ensure the key switch is set to OFF position before removing the battery.
2. Remove the driver's seat. See the Seats section for details.
3. Disconnect the black (negative) battery cable first, and secure away from the battery terminals.
4. Disconnect the red (positive) battery cable last.
5. Remove the battery hold-down strap.
6. Lift the battery out of the Tractor.

## BATTERY INSTALLATION

Using a new battery that has not been fully charged can damage the battery and result in a shorter life. It can also hinder Tractor performance. Follow the instructions in the Battery Charging section before installing the battery.

1. Ensure that the battery is fully charged.
2. Place the battery in the battery holder.
3. Coat the terminals with dielectric grease or petroleum jelly.
4. Secure the battery hold-down strap.
5. Connect and tighten the red (positive) cable first.
6. Connect and tighten the black (negative) cable last.

## MAINTENANCE

---

7. Verify that cables are properly routed.
8. Reinstall the seat.

## BATTERY MAINTENANCE AND CHARGING

### WARNING

An overheated battery may explode, causing severe injury or death. Always watch charging times carefully. Stop charging if the battery becomes very warm to the touch. Allow it to cool before resuming charging.

### WARNING

The sealed battery is already filled with electrolyte and has been sealed and *fully charged* at the factory. *Never* pry the sealing strip off or add any other fluid to this battery. It contains sulfuric acid. Serious burns can result from contact with skin, eyes, or clothing.

The single most important thing about maintaining a sealed battery is to keep it fully charged. Check the battery voltage with a voltmeter or multimeter. A fully charged battery will register 12.8 V or higher. If the voltage falls below 12.5V, charge it immediately, or the battery runs the risk of sulfation and reduced battery life.

This Tractor is equipped with a Tractor battery charge port located on the dash. This allows the operator to charge the Tractor battery without needing to access the battery under the driver's seat.

If you do not drive the Tractor for more than TWO WEEKS, Egimotors recommends using a BatteryMINDER® 2012 AGM - 2 AMP charger (PN 2830438), which can be ordered through your dealer.



If you plan to store the Tractor for ONE MONTH or longer, remove the battery from the Tractor, then store the battery in a cool and dry location. Continue to maintain the battery with the BatteryMINDER® 2012 AGM - 2 AMP charger.

When using an automatic charger other than a BatteryMINDER® 2012-AGM - 2 AMP charger, refer to the charger manufacturer's instructions for recharging.

**USING A CONSTANT CURRENT CHARGER**

If you are using a **constant current charger** (instead of BatteryMINDer® 2012 AGM - 2 AMP charger), use the guidelines below. Always verify battery condition before and 1-2 hours after the end of charging.

State of Charge	Voltage (DC)	Action	Charge Time*
100%	12.8-13.0 volts	None, check monthly	None required
75%-100%	12.6-12.8 volts	May need slight charge, if no charge given, check in 2 weeks	3-6 hours
50%-75%	12.3-12.6 volts	Needs charge	5-11 hours
25%-50%	12.0-12.3 volts	Needs charge	At least 13 hours
0%-25%	12.0 volts or less	Needs charge	At least 20 hours
* Using AGM specific charger at standard amps specified on top of battery			

## MAINTENANCE

# CLEANING AND STORAGE

## WASHING THE TRACTOR

Keeping your EGIMOTORS Tractor clean will not only improve its appearance, but it can also extend the life of various components.

### NOTE

All sealed storage compartments in the Tractor are element-resistant but not water-proof. Remove items from storage compartments before cleaning to avoid water damage.

### NOTICE

Water in the PVT system could cause the drive belt to become wet and slip in the clutches. Always avoid spraying water directly toward any intake pre-filters (1). If water is sprayed into the pre-filters, perform the drying procedures described in the PVT Drying section.

High water pressure may damage radiator fins and impair a radiator's effectiveness. High pressure may also damage other Tractor components.

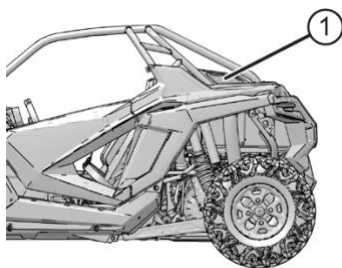

Certain products, including insect repellents and chemicals, will damage plastic surfaces. Do not allow these types of products to contact the Tractor.

The best and safest way to clean your EGIMOTORS Tractor is with a garden hose and a pail of mild soap and water.

1. Use a professional-type washing cloth, cleaning the upper body first and the lower parts last.
2. Rinse with clean water frequently.
3. Dry surfaces with a chamois to prevent water spots.

If a high-pressure water system is used for cleaning (not recommended), exercise extreme caution. The water may damage components and could remove paint and labels. Avoid directing the water stream at the following items:

- Wheel bearings
- Radiators
- Transmission seals
- Brakes
- Cab and body panels
- Labels and decals
- Electrical components and wiring
- Air intake components

If warning and safety labels are damaged, contact your EGIMOTORS dealer for free replacement.

Grease all zerk fittings immediately after washing. Allow the engine to run for a while to evaporate any water that may have entered the engine or exhaust system.

### **WASHING TIPS**

- Avoid the use of harsh cleaners, which can scratch the finish.
- Do not use a power washer to clean the Tractor.
- Do not use medium to heavy duty compounds on the finish.
- Always use clean cloths and pads for cleaning and polishing. Old or reused cloths and pads may contain dirt particles that will scratch the finish.

### **POLISHING THE TRACTOR**

EGIMOTORS recommends the use of common household aerosol furniture polish for polishing the finish on your EGIMOTORS Tractor. Follow the instructions on the container.

### **POLISHING TIPS**

- Avoid the use of automotive products, some of which can scratch the finish of your Tractor.
- Always use clean cloths and pads for cleaning and polishing. Old or reused cloths and pads may contain dirt particles that will scratch the finish.
- Avoid the use of products containing a colorant dye. Test any products on an inconspicuous area of the Tractor before using throughout.

## MAINTENANCE

---

### STORAGE TIPS

#### NOTICE

Starting the engine during the storage period will disturb the protective film created by fogging and damage could occur. Never start the engine during the storage period.

### **CLEAN THE EXTERIOR**

Make any necessary repairs and clean the Tractor as recommended. See the Washing the Tractor section for details.

### **STABILIZE THE FUEL**

1. Fill the fuel tank.
2. Add POLARIS Carbon Clean Fuel Treatment or EGIMOTORS Fuel Stabilizer or equivalent fuel treatments or stabilizers. Follow the instructions on the container for the recommended amount. Carbon Clean removes water from fuel systems, stabilizes fuel and removes carbon deposits from pistons, rings, valves and exhaust systems.
3. Allow the engine to run for 15-20 minutes to allow the stabilizer to disperse through the entire fuel delivery system.

### **OIL AND FILTER**

Change the oil and filter. See the Oil and Filter Change section for details.

### **AIR FILTER / AIR BOX**

Replace the air filter. See the Air Filter section for details. Clean the air box.

### **FLUID LEVELS**

Inspect the fluid levels. Add or change fluids as recommended in the Periodic Maintenance Chart section.

- Demand drive fluid (front gearcase)
- Rear gearcase fluid (if equipped)
- Transmission fluid
- Brake fluid (change every two years and any time the fluid looks dark or contaminated)
- Coolant (test strength/fill)

### **INSPECT AND LUBRICATE**

Inspect all cables and lubricate all areas of the Tractor as recommended in the Periodic Maintenance Chart section.



### **FOG THE ENGINE**

1. Treat the fuel system with EGIMOTORS Carbon Clean or other equivalent fuel treatment. Follow the instructions on the container. Start the engine. Allow it to idle for several minutes so the Carbon Clean reaches the injectors. Stop the engine.
2. Remove the spark plugs and add 2-3 tablespoons of engine oil. To access the plug holes, use a section of clear 1/4" hose and a small plastic squeeze bottle filled with the pre-measured amount of oil. *Do this carefully! If you miss the plug holes, oil will drain from the spark plug cavities into the hole at the front of the cylinder head and appear to be an oil leak.*
3. Reinstall the spark plugs. Torque to specification. See the Spark Plug Gap / Torque section for details.
4. Apply dielectric grease to the inside of each spark plug cap. *Do not reinstall the caps onto the plugs at this step.*
5. Turn the engine over several times. Oil will be forced in and around the piston rings and ring lands, coating the cylinder with a protective film of fresh oil.
6. If EGIMOTORS fuel system additive is not used, fuel tank, fuel lines, and injectors should be completely drained of gasoline.
7. Reinstall the spark plug caps to the spark plugs.

### **BATTERY MAINTENANCE**

See Battery section for storage and charging procedures.

### **FUSE BOX**

Remove the fuse box cover during storage.

### **STORAGE AREA / COVERS**

Be sure the storage area is well ventilated. Cover the Tractor with a genuine EGIMOTORS cover. Do not use plastic or coated materials. They do not allow enough ventilation to prevent condensation and may promote corrosion and oxidation.

### **REMOVAL FROM STORAGE**

1. Charge the battery if necessary.
2. Make sure the spark plug is tight. Reinstall the fuse box cover if it was removed for storage.
3. Fill the fuel tank with fuel.

## MAINTENANCE

---

4. Check all the points listed in the Daily Pre-Ride Inspection section. Tightness of the bolts, nuts and other fasteners should be checked by an authorized EGIMOTORS dealer or other qualified service facility.
5. Lubricate at the intervals outlined in the Periodic Maintenance Chart section.

 **WARNING**

Engine exhaust contains poisonous carbon monoxide and can cause loss of consciousness or death. Never run an engine in an enclosed area.

## TRANSPORTING THE TRACTOR

### WARNING

Cargo and other loose Tractor parts may fly off while transporting this Tractor. Secure or remove all cargo, and inspect the unit for loose parts prior to transport.

If transporting the Tractor in a non-enclosed trailer, then the Tractor must FACE FORWARD, or roof must be removed.

Failure to comply may allow airflow, vibration, or other factors to separate the roof from the Tractor and cause an accident, resulting in serious personal injury or death.

### NOTE

For functional descriptions detailing how to operate the DYNAMIX suspension system on certain Tractor models, consult the *POLARIS RideCommand*

Follow these procedures when transporting the Tractor.

### NOTICE

After a ride, allow the engine to idle for 30 seconds before stopping the engine. This will allow the turbo system to cool down.

1. Place the transmission in PARK.
2. Stop the engine. Turn the key back on to the accessory or ON position without starting the engine. Slowly release the brake pedal and make sure the transmission is in PARK before exiting the Tractor, verifying that the PARK position is shown on the display.
3. Prior to securing the Tractor, the key switch must remain in the ON position, the suspension mode switch must be in the COMFORT setting, and the demo mode timeout must not be active while securing the Tractor. Shock damping settings can be verified on the Suspension visualization screen.
4. Secure the Tractor.

### WARNING

Tractors equipped with DYNAMIX active suspension must be powered on, set to COMFORT mode, and properly functioning in order to ensure the shocks are operating at their minimum compression damping setting prior to securing the Tractor for transport. Failure to ensure the shocks are in their minimum compression damping setting prior to securing the Tractor can potentially lead to a reduction of intended strap tension while trailering.

## MAINTENANCE

---

5. After the Tractor has been secured, verify the gauge indicates PARK, and turn the Tractor power off. Verify also that the suspension compression damping values are still soft after securing the Tractor. If after securing the suspension demo mode has timed out or the suspension has moved to a FIRM setting as indicated on the Suspension control screen, cycle the key switch, place the mode switch in COMFORT mode, and re-tighten the straps per step number 3.
6. Remove the key to prevent loss during transporting. Secure the fuel cap and seats. Ensure that the seats are attached correctly and are not loose.

### WARNING

Cargo and other loose Tractor parts may fly off while transporting this Tractor. Secure or remove all cargo, and inspect the unit for loose parts prior to transport.

7. Always tie the frame of the EGIMOTORS Tractor to the transporting unit securely with suitable straps or rope. Do not attach tie straps to the front control arm bolt pockets.

q Rear Tie-Down (both sides)

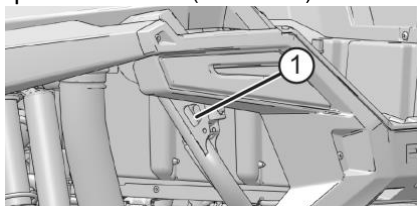

w Front Tow Loop Tie-Down

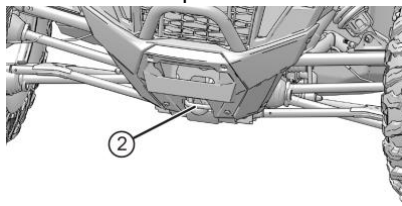

**RZR PRO XP 4**

Dry Weight	944 kg
Rear Cargo Box Capacity	80 kg
Maximum Weight Capacity (Payload)	490 kg
Fuel Capacity	(49 L)
Engine Oil Capacity	(2.6 L)
Coolant Capacity	(11.3 L)
Demand Drive Fluid Capacity	(280 ml)
Transmission Oil Capacity	(1800 ml)
Overall Length/Width/Height	(394 / 182 / 189 cm)
Wheelbase	(318 cm)
Ground Clearance	(36 cm)

## SPECIFICATIONS

---

Engine	4-Stroke DOHC Twin Cylinder
Displacement	925 cc
Bore x Stroke	93mm x 68mm
Alternator Output	900W @ 3000 RPM
Compression Ratio	9.0:1
Starting System	Electric
Fuel System	Electronic fuel injection
Ignition System	ECU
Spark Plug / Gap	NGK® MR9F / 0.7-0.8 mm
Front Suspension	Independent double a-arm with (43.2 cm) travel
Rear Suspension	Independent trailing arms with (50.8 cm) travel
Lubrication System	Wet Sump
Driving System Type	Automatic EGIMOTORS Variable Transmission
Shift Type	Dual Range P/R/N/L/H
Tire Size - Front	30x10 R14
Tire Size - Rear	30x10 R14
Tire Pressure Bar	Front: 1 Rear: 1,8
Brakes, Front/Rear	Foot Activated, 4-wheel hydraulic disc
Headlights	2 dual beam LED cluster
Taillights	2 LED cluster
Brake Lights	2 LED cluster
Instrument Cluster	LCD
Auxiliary DC Outlet	12V

---

**OUTPUT GEAR RATIOS**

<b>Rear</b>	
High Gear	12.51:1
Low Gear	20.36:1
Reverse	26.33:1
<b>Front (including front drive)</b>	
High Gear	13.17:1
Low Gear	21.41:1
Reverse	27.71:1
Drive Ratio - Front	3.17:1

## TROUBLESHOOTING

### DRIVE BELT WEAR / BURN

POSSIBLE CAUSE	SOLUTION
Driving onto a pickup or tall trailer in high range	Use low range during loading.
Starting out going up a steep incline	Use low gear.
Driving at low RPM or ground speed (3-7 MPH/ 5-11 km/h)	Drive at a higher speed or use low range more frequently. See the Gear Selector section for details.
Insufficient warm-up at low ambient temperatures	Warm the engine at least 5 minutes. With the transmission in neutral, advance the throttle to about 1/8 throttle in short bursts, 5 to 7 times. The belt will become more flexible and prevent belt burning.
Slow/easy clutch engagement	Use the throttle quickly and effectively.
Hauling heavy cargo/pushing at low RPM/low ground speed	Use low gear only.
Utility use/plowing	Use low gear only.
Stuck in mud or snow	Shift the transmission to low range and carefully use fast, aggressive throttle application to engage clutch. <b>WARNING!</b> Excessive throttle may cause loss of control and Tractor rollover.
Climbing over large objects from a stopped position	Shift the transmission to low range and carefully use fast, brief, aggressive throttle application to engage clutch. <b>WARNING!</b> Excessive throttle may cause loss of control and Tractor rollover.



## TROUBLESHOOTING

<p>Belt slippage from water or snow ingestion into the PVT system</p>	<p>Dry out the PVT (see the PVT Drying section for details). Prevent water from entering the PVT outlet duct (see page 137). Inspect clutch seals for damage if repeated leaking occurs.</p>
---	--

## TROUBLESHOOTING

---

POSSIBLE CAUSE	SOLUTION
Clutch malfunction	Your EGIMOTORS dealer can assist.
Poor engine performance	Check for fouled plugs or foreign material in gas tank or fuel lines. Your EGIMOTORS dealer can assist.
Slippage from failure to warm up belt	Always warm up the belt by operating below 30 MPH (48 km/h) for one mile (1.5 km) and for 5 miles (8 km) or more when temperature is below freezing.
Wrong or missing belt	Install the recommended belt.
Improper break-in	Always break-in a new belt and/or clutch. See page 94.
Failed belt	Remove the belt and clean away any debris from the clutch box, clutch duct and engine compartment. Install a new belt. <b>WARNING!</b> Failure to remove ALL debris when replacing the belt could result in Tractor damage and severe injury or death. See the Belt Replacement / Debris Removal section for details.

**ENGINE DOESN'T TURN OVER**

<b>POSSIBLE CAUSE</b>	<b>SOLUTION</b>
Low battery voltage	Recharge the battery to 12.8 VDC
Loose battery connections	Check all connections and tighten
Loose solenoid connections	Check all connections and tighten
Loose electronic control box connections	Inspect, clean, reinstall connectors; blow on EFI fuse to remove impurities
Mechanical failure	Your EGIMOTORS dealer or other qualified person can assist.

**ENGINE TURNS OVER, FAILS TO START**

<b>POSSIBLE CAUSE</b>	<b>SOLUTION</b>
Out of fuel	Refuel
Clogged fuel filter	Your EGIMOTORS dealer or other qualified person can assist.
Water is present in fuel	Drain the fuel system and refuel
Old or non-recommended fuel	Replace with fresh recommended fuel
Fouled or damaged spark plugs	Inspect plugs and replace if necessary
No spark to spark plug	Inspect plugs and replace if necessary
Water or fuel in crankcase	Your EGIMOTORS dealer or other qualified person can assist.
Low battery voltage	Recharge the battery to 12.8 VDC
Loose ignition connections	Check all connections and tighten
Mechanical failure	Your EGIMOTORS dealer or other qualified person can assist.

## TROUBLESHOOTING

---

### ENGINE BACKFIRES

POSSIBLE CAUSE	SOLUTION
Out of fuel	Refuel
Weak spark from spark plug	Inspect, clean and/or replace spark plugs
Incorrect spark plug gap or heat range	Set gap to specs or replace plugs
Old or non-recommended fuel	Replace with fresh recommended fuel
Incorrectly installed spark plug wires	Your EGIMOTORS dealer or other qualified person can assist.
Incorrect ignition timing	Your EGIMOTORS dealer or other qualified person can assist.
Loose ignition connections	Check all connections and tighten
Water present in fuel	Replace with fresh recommended fuel
Exhaust leak	Check all connections
Mechanical failure	Your EGIMOTORS dealer or other qualified person can assist.

### ENGINE PINGS OR KNOCKS

POSSIBLE CAUSE	SOLUTION
Poor quality or low octane fuel	Replace with recommended fuel
Incorrect ignition timing	Your EGIMOTORS dealer or other qualified person can assist.
Incorrect spark plug gap or heat range	Set gap to specs or replace plugs

## ENGINE RUNS IRREGULARLY, STALLS OR MISFIRES

POSSIBLE CAUSE	SOLUTION
Loose, missing or kinked boost reference lines	Replace boost reference lines
Loose or missing intake system sensor connections	Inspect connections, tighten or replace as needed
Fouled or defective spark plugs	Inspect, clean and/or replace spark plugs
Worn or defective spark plug wires	Your EGIMOTORS dealer can assist.
Incorrect spark plug gap or heat range	Set gap to specs or replace plugs
Loose ignition connections	Check all connections and tighten
Water present in fuel	Replace with new fuel
Low battery voltage	Recharge battery to 12.8 VDC
Kinked or plugged fuel tank vent line or filter	Inspect and replace
Incorrect fuel	Replace with recommended fuel
Clogged air filter	Inspect and replace clogged/wet air filter, and also check for obstructed intake system, debris or cargo blocking intake vents
Clogged intake pre-filter	Inspect and clean (with soapy water) or replace
Other mechanical failure	Your EGIMOTORS dealer can assist.
Possible Lean Fuel Cause	Solution
Low or contaminated fuel	Add or change fuel, clean the fuel system
Low octane fuel	Replace with recommended fuel
Clogged fuel filter	Your EGIMOTORS dealer can assist.

## TROUBLESHOOTING

Low fuel pressure	Your EGIMOTORS dealer can assist.
Loose, missing, torn or kinked boost reference line from manifold to fuel pressure regulator or blow-off valve	Replace boost reference line

## ENGINE STOPS OR LOSES POWER

POSSIBLE CAUSE	SOLUTION
Out of fuel	Refuel
Kinked or plugged fuel tank vent line or filter	Inspect and replace
Water is present in fuel	Replace with new fuel
Fouled or defective spark plugs	Inspect, clean and/or replace spark plug
Worn or defective spark plug wires	Your EGIMOTORS dealer can assist.
Incorrect spark plug gap or heat range	Set gap to specs or replace plug
Loose ignition connections	Check all connections and tighten
Low battery voltage	Recharge the battery to 12.8 VDC
Incorrect fuel	Replace with fresh recommended fuel
Clogged air filter	Inspect and replace
Clogged intake pre-filter	Inspect and clean (with soapy water) or replace
Other mechanical failure	Your EGIMOTORS dealer can assist.
Overheated engine	Clean radiator screen and core, clean engine exterior, check coolant level. Your EGIMOTORS dealer can assist.
Loose, missing, torn or kinked boost reference line from manifold to fuel pressure regulator or blow-off valve	Replace boost reference line
Loose, missing, torn or kinked boost reference line from turbo compressor to boost control valve	Replace boost reference line



<b>POSSIBLE CAUSE</b>	<b>SOLUTION</b>
Loose intake system connections	Inspect connections, tighten or replace as needed
Worn or defective wastegate actuation system	Your EGIMOTORS dealer can assist.
Overheated intake air system	Inspect intercooler water lines for leaks or kinks, repair or replace as needed



## WARRANTY

### LIMITED WARRANTY

EGIMOTORS gives a TWO-YEAR LIMITED WARRANTY on all components of your Tractor against defects in material or workmanship.

This warranty covers parts and labor charges for repair or replacement of defective parts and begins on the date of purchase by the original retail purchaser.

This warranty is transferable to another owner during the warranty period through a dealer, but any such transfer will not extend the original term of the warranty.

### REGISTRATION

At the time of sale, the Warranty Registration Form must be completed by your dealer and submitted to EGIMOTORS within ten days of purchase. Upon receipt of this registration, EGIMOTORS will record the registration for warranty. No verification of registration will be sent to the purchaser as the copy of the Warranty Registration Form will be your proof of warranty coverage. If you have not signed the original registration and received the customer copy, please contact your dealer immediately. **NO WARRANTY COVERAGE WILL BE ALLOWED UNLESS YOUR VEHICLE IS REGISTERED WITH EGIMOTORS.** Initial

dealer preparation and set-up of your vehicle is very important in ensuring trouble-free operation. Purchasing a machine in the crate or without proper dealer set-up will void your warranty coverage.

## WARRANTY

---

### WARRANTY COVERAGE AND EXCLUSIONS

#### LIMITATIONS OF WARRANTIES AND REMEDIES

This EGIMOTORS limited warranty excludes any failures that are not caused by a defect in material or workmanship. THIS WARRANTY DOES NOT COVER CLAIMS OF DEFECTIVE DESIGN. This warranty also does not cover acts of God, accidental damage, normal wear and tear, abuse or improper handling. This warranty also does not cover any Tractor, component, or part that has been altered structurally, modified, neglected, improperly maintained or used for racing, competition or purposes other than for which it was designed.

This warranty excludes damages or failures resulting from improper lubrication; improper engine timing; improper fuel; surface imperfections caused by external stress, heat, cold or contamination; operator error or abuse; improper component alignment, tension, adjustment or altitude compensation; snow, water, dirt or other foreign substance ingestion/contamination; improper maintenance; modified components; use of aftermarket or unapproved components, accessories, or attachments; unauthorized repairs; or repairs made after the warranty period expires or by an unauthorized repair center.

This warranty excludes damages or failures caused by abuse, accident, fire, or any other cause other than a defect in materials or workmanship and provides no coverage for consumable components, general wear items, or any parts exposed to friction surfaces, stresses, environmental conditions and/or contamination for which they were not designed or not intended, including but not limited to the following items:

- Wheels and tires
- Suspension components
- Brake components
- Seat components
- Clutches and components
- Steering components
- Batteries
- Light bulbs/Sealed beam lamps
- Filters
- Lubricants
- Bushings
- Finished and unfinished surfaces
- Carburetor/Throttle body components
- Engine components
- Drive belts
- Hydraulic components and fluids
- Circuit breakers/Fuses
- Electronic components
- Spark plugs
- Sealants
- Coolants
- Bearings

## LUBRICANTS AND FLUIDS

1. Mixing oil brands or using non-recommended oil may cause engine damage. We recommend the use of EGIMOTORS engine oil.
2. Damage or failure resulting from the use of non-recommended lubricants or fluids is not covered by this warranty.

This warranty provides no coverage for personal loss or expense, including mileage, transportation costs, hotels, meals, shipping or handling fees, product pick-up or delivery, replacement rentals, loss of product use, loss of profits, or loss of vacation or personal time.

THE EXCLUSIVE REMEDY FOR BREACH OF THIS WARRANTY SHALL BE, AT EGIMOTORS' OPTION, REPAIR OR REPLACEMENT OF ANY DEFECTIVE MATERIALS, COMPONENTS, OR PRODUCTS. THE REMEDIES SET FORTH IN THIS WARRANTY ARE THE ONLY REMEDIES AVAILABLE TO ANY PERSON FOR BREACH OF THIS WARRANTY. EGIMOTORS SHALL HAVE NO LIABILITY TO ANY PERSON FOR INCIDENTAL, CONSEQUENTIAL OR SPECIAL DAMAGES OF ANY DESCRIPTION, WHETHER ARISING OUT OF EXPRESS OR IMPLIED WARRANTY OR ANY OTHER CONTRACT, NEGLIGENCE, OR OTHER TORT OR OTHERWISE. THIS EXCLUSION OF CONSEQUENTIAL, INCIDENTAL, AND SPECIAL DAMAGES IS INDEPENDENT FROM AND SHALL SURVIVE ANY FINDING THAT THE EXCLUSIVE REMEDY FAILED OF ITS ESSENTIAL PURPOSE.

THE IMPLIED WARRANTY OF FITNESS FOR A PARTICULAR PURPOSE IS EXCLUDED FROM THIS LIMITED WARRANTY. ALL OTHER IMPLIED WARRANTIES (INCLUDING BUT NOT LIMITED TO THE IMPLIED WARRANTY OF MERCHANTABILITY) ARE LIMITED IN DURATION TO THE ABOVE SIX MONTH WARRANTY PERIOD. EGIMOTORS DISCLAIMS ALL EXPRESS WARRANTIES NOT STATED IN THIS WARRANTY. SOME STATES DO NOT PERMIT THE EXCLUSION OR LIMITATION OF INCIDENTAL OR CONSEQUENTIAL DAMAGES OR ALLOW LIMITATIONS ON THE DURATION OF IMPLIED WARRANTIES, SO THE ABOVE LIMITATIONS MAY NOT APPLY TO YOU IF INCONSISTENT WITH CONTROLLING STATE LAW.

## WARRANTY

---

### HOW TO OBTAIN WARRANTY SERVICE

If your Tractor requires warranty service, you must take it to a EGIMOTORS Servicing Dealer. When requesting warranty service you must present your copy of the Warranty Registration Form to the dealer. (THE COST OF TRANSPORTATION TO AND FROM THE DEALER IS YOUR RESPONSIBILITY.) EGIMOTORS suggests that you use your original selling dealer; however, you may use any EGIMOTORS Servicing Dealer to perform warranty service.

#### ***In the Country where your product was purchased:***

Warranty or Service Bulletin repairs must be done by an authorized EGIMOTORS dealer. If you move or are traveling within the country where your product was purchased, Warranty and Service Bulletin repairs may be requested from any authorized EGIMOTORS dealer that sells the same line as your product.

#### ***Outside the Country where your product was purchased:***

If you are traveling temporarily outside the country where your product was purchased, you should take your product to an authorized EGIMOTORS dealer. You must show the dealer photo identification from the country of the selling dealer's authorized location as proof of residence. Upon residence verification, the servicing dealer will be authorized to perform the warranty repair.

#### ***If you move:***

If you move to another country, be sure to contact EGIMOTORS Customer Assistance and the customs department of the destination country before you move. Product importation rules vary considerably from country to country. You may be required to present documentation of your move to EGIMOTORS in order to continue your warranty coverage. You may also be required to obtain documentation from EGIMOTORS in order to register your product in your new country. You should warranty register your product at a local EGIMOTORS dealer in your new country immediately after you move to continue your warranty coverage and to ensure that you receive information and notices regarding your Tractor.

#### ***If you purchase from a private party:***

If you purchase a EGIMOTORS product from a private party, to be kept and used outside of the country in which the product was originally purchased, all warranty coverage will be denied. You must nonetheless register your product under your name and address with a local EGIMOTORS dealer in your country to ensure that you receive safety information and notices regarding your product.

### **NOTICE**

If your product is registered outside of the country where it was purchased and you have not followed the procedure set above, your product will no longer be eligible for warranty or service bulletin coverage of any kind, other than safety recalls. Products registered to government officials or military personnel on assignment outside of the country where the product was purchased will continue to be covered by the Limited Warranty.

Please work with your dealer to resolve any warranty issues. Dealership contacts can be found via this website, if needed:

[www.Egimotors.it](http://www.Egimotors.it)

Should your dealer require any additional assistance, they will contact the appropriate person at EGIMOTORS.









# Tractor Certificate of Pre-Delivery

Year \_\_\_\_\_ Model \_\_\_\_\_

VIN \_\_\_\_\_

Engine Serial Number \_\_\_\_\_

Key Number \_\_\_\_\_ Km / Hours \_\_\_\_\_

Registration Plate Number \_\_\_\_\_

## ASSEMBLY / SERVICE / INSPECTION

- - SEALED BATTERY – Apply dielectric grease to terminal bolts and install cable. Check Voltage and charge if below 12,8 Volts.
- - BATTERY VOLTAGE – Misuse and record the battery voltage after 30 minutes after charger has been removed \_\_\_\_\_ DCV
- - TIRE PRESSURE – Verify Pressure if set to Specification
- - WHEEL NUT – Torque to specification
- - HANDLEBAR CLAMPS - Torque bolts to specification
- - MASTER CYLINDER – Torque bolts to specification
- - FRONT TOE ALIGMENT – Verify proper toe setting
- - BALL JOINT – Inspect bolts and/or cotter pin
- - STEERING POST – Inspect cotter pin
- - TIE ROD – Inspect jam nuts and cotter pin
- - TRANSMISSION – Add oil if needed
- - GREASE FITTING – Check and Grease all the Fitting if needed
- - ENGINE OIL – Check level of oil, add if needed
- - BRAKE FLUID – Check level of fluid, add if needed in brake master cylinder(s)
- - ENGINE COOLANT – Inspect coolant in recovery bottle. Add if needed.
- - PARK BRAKE – Verify proper operation
- - INTAKE AIRBOX – Inspect hose connection and clamps. Inspect filter condition.
- - LIGHTS – Verify operation of all lights
- - FUEL – Check level of fuel and add if needed
- - WIRE HARNESS / HOSE/ LINES – Inspect wire, hoses, and line from kinks, pinching and sign of abrasion.
- - UNIT INQUIRY – Check in the system and complete applicable Service Bulletins Recalls or factory direct modification(s)
- - COSMETIC INSPECTION – Inspect the quadricycle for damage and proper fit and finish.

DEALERSHIP NAME \_\_\_\_\_ # \_\_\_\_\_

ASSEMBLED BY \_\_\_\_\_

DATE \_\_\_\_\_ / \_\_\_\_\_ / \_\_\_\_\_

SIGNATURE

STAMP

# Tractor Certificate of Pre-Delivery

Year \_\_\_\_\_ Model \_\_\_\_\_

VIN \_\_\_\_\_

Engine Serial Number \_\_\_\_\_

Key Number \_\_\_\_\_ Km / Hours \_\_\_\_\_

Registration Plate Number \_\_\_\_\_

## TEST RIDE

- - ENGINE – Starting acceleration and smoothness.
- - IDLE SPEED – Verify when cold and hot the engine idle properly.
- - TROTTLE – With engine idling and transmission in Neutral, swing the handlebar through entire travel range and verify proper and smooth operation.
- - ETC - Verify proper operation and throttle free play.
- - AUXILIARY SHUT OFF SWITCH - Verify proper operation.
- - BRAKES - Verify proper operation. Torque bolts to specification
- - DRIVELINE – Verify smooth operation
- - CLUTCH / TRANSMISSION – Verify proper shifting and transmission engagement/ indicator lights must correspond with gears.
- - AWD ADC – Verify proper operation.
- - REVERSE SPEED LIMITER – Verify operation and override control.
- - INSTRUMENTATION – Verify operational reading.
- - WHINCH (If equipped) – Verify proper operation.
- - SUSPENSION / STEERING – Verify adjustment, stability and operation.
- - ENGINE COOLANT Inspect coolant in recovery bottle between Min and Max after test ride, add if necessary.
- - DIAGNOSTIC SYSTEM – Run Engine up to full operating temperature. Use digital Wrench to generate and submit a “Service Report” recommended Process.
- - LEAKEAGE – After completing “Diagnostic System “check for leakage and verify proper connection of oil / exhaust / fuel / Coolant / Brake fluid fitting, inspect hoses for sign and abrasion.
- - CLEAN – Wash and clean the quadricycle before delivery.

TEST RIDDEN BY \_\_\_\_\_

DATE \_\_\_\_\_ / \_\_\_\_\_ / \_\_\_\_\_

SIGNATURE

STAMP

# Tractor Certificate of Pre-Delivery

Year \_\_\_\_\_ Model \_\_\_\_\_

VIN \_\_\_\_\_

Engine Serial Number \_\_\_\_\_

Key Number \_\_\_\_\_ Km / Hours \_\_\_\_\_

Registration Plate Number \_\_\_\_\_

## DELIVERY TO CUSTOMER

- - WARRANTY REGISTRATION FORM – Completed and signed.
- - OWNERS MANUAL – Emphasize the importance of reading for customer Safety and Servicing of Quadricycle/ Explain periodic maintenance responsibilities.
- - WARRANTY POLICY – Explanation / Limit / Requirements.
- - KEYS - Record Key Number.
- - Controls – Show location and function.
- - BELT LIFE – Discuss proper operation procedure operating and proper use of High and Low Gear Range.
- - BREAK IN PROCEDURE – Review as outline in Owner's Manual.
- - STORAGE / FUELING / TRANSPORTATION – Review as outline in the owner's manual.
- - TOOL KIT – Show location.
- - Safety Video – Review with Customer.
- - SAFETY FEATURES – Review all safety features of quadricycle operation for new operation.
- - DRIVING PROCEDURE – Review Operator driving procedure outlined in the Owner's Manual.
- - SVIA TRAINING FACT SHEET – Review with customer.
- - SAFETY TRAINING COURSE SVIA – I have instructed the owner on the authorized SVIA Safety training online course.
- - PRE-DELIVERY CERTIFICATION – I certify that pre-delivery inspection and service have been perform on this vehicle in accordance with the instructions issued by Egimotors.

DEALERSHIP NAME \_\_\_\_\_ # \_\_\_\_\_

DELIVERED BY \_\_\_\_\_

DATE \_\_\_\_\_ / \_\_\_\_\_ / \_\_\_\_\_

SIGNATURE

STAMP

# Tractor Certificate of Pre-Delivery

Year \_\_\_\_\_ Model \_\_\_\_\_

VIN \_\_\_\_\_

Engine Serial Number \_\_\_\_\_

Key Number \_\_\_\_\_ Km / Hours \_\_\_\_\_

Registration Plate Number \_\_\_\_\_

## CUSTOMER ACCEPTANCE

- - I have reviewed the Egimotors warranty Policy / Policies
- - I have inspected the Quadricycle and it meets my satisfaction.
- - I understand the importance of following the Owner's Manual and instructions.
- - I understand the importance of using all safety features.

Review with customer.

- - I understand the importance of all operation following the operator driving procedures in the Owner's Manual.
- - I have been instructed on the authorized online SVIA training course by my Dealer \_\_\_\_\_

(Name of dealership and person who inform the Customer)

CUSTOMER NAME \_\_\_\_\_

CUSTOMER SIGNATURE

DATE \_\_\_\_\_ / \_\_\_\_\_ / \_\_\_\_\_

# *Egimotors*

Via Filippo da Desio 49/51  
20832 Desio (MB) ITALY  
info@polarisitalia.com

For more informations  
visit [www.Egimotors.it](http://www.Egimotors.it)

