

Egimotors

2024

OWNER'S MANUAL

TRACTOR

SPORTSMAN 6x6 570

Owner's manual part Number - OM24TRSPME6X6

Read this manual carefully. It contains important safety information. This is an adult Quadricycle only.
Operation is prohibited for those under 18 years of age.

 **WARNING**

This Owner Manual refers to EGIMOTORS TRACTOR
(To be filled in by your Dealer)

This Owner's Manual should always remain inside your TRACTOR.
A digital/printable copy is available on www.egimotors.com

Year _____

Model Type _____

Code number (spare parts use only) _____

VIN Number _____

Engine Serial Number _____

Key Number _____

Registration Plate Number _____



WELCOME

Thank you for purchasing an Egimotors Tractor, and welcome to our world-wide family of enthusiasts. Be sure to visit us online at www.Egimotors.it for the latest news, new product introductions, upcoming events, career opportunities and more.

We proudly produce an exciting line of utility and recreational products. We believe we sets a standard of excellence for all utility and recreational Tractor s manufactured in the world today.

Many years of experience have gone into the engineering, design, and development of your Tractor , making it the finest machine we've ever produced.

For safe and enjoyable operation of your Tractor , be sure to follow the instructions and recommendations in this owner's manual. Your manual contains instructions for minor maintenance, but information about major repairs is outlined in the Service Manual and can be performed by a factory certified Master Service Dealer (MSD) technician.

Your dealer knows your Tractor best and is interested in your total satisfaction. Your dealership can perform all of your service needs during and after the warranty period.

For the most up-to-date owner's manual visit:

<http://egimotors.it/libretto-uso-manuten>

Copyright 2024 Egimotors . All information contained within this publication is based on the latest product information at the time of publication. Due to constant improvements in the design and quality of production components, some minor discrepancies may result between the actual Tractor and the information presented in this publication. Depictions and/or procedures in this publication are intended for reference use only. No liability can be accepted for omissions or inaccuracies. Any reprinting or reuse of the depictions and/or procedures contained within, whether whole or in part, is expressly prohibited.

The original instructions for this Tractor are in English. Other languages are provided as translations of the original instructions

INTRODUCTION

IMPORTANT WARNING ABOUT THIS MANUAL



WARNING

Failure to heed the warnings and safety precautions contained in this manual can result in severe injury or death. A Tractor is not a toy and can be hazardous to operate. This Tractor handles differently than other Tractor, such as motorcycles and cars. A collision or rollover can occur quickly, even during routine maneuvers like turning, or driving on hills or over obstacles, if you fail to take proper precautions.

- Read this owner's manual. Understand all safety warnings, precautions and operating procedures before operating an Egimotors Tractor.
- Keep this manual with the Tractor.
- Never operate a Tractor without proper instruction. Take a certified Tractor safety training course.
- This Tractor is an **ADULT TRACTOR ONLY**. Operation is prohibited for anyone under 18 years of age.
- Never permit a guest to operate the Tractor unless the guest has read this manual and all product labels and has completed a certified safety training course at a training school

SAFETY SYMBOLS AND SIGNAL WORDS

The following signal words and symbols appear throughout this manual and on your Tractor . Your safety is involved when these words and symbols are used. Become familiar with their meanings before reading the manual.

DANGER

DANGER indicates a hazardous situation which, if not avoided, WILL result in death or serious injury.

WARNING

WARNING indicates a hazardous situation which, if not avoided, COULD result in death or serious injury.

CAUTION

CAUTION indicates a hazardous situation which, if not avoided, COULD result in minor to moderate injury.

NOTICE

NOTICE provides key information by clarifying instructions.

IMPORTANT

IMPORTANT provides key reminders during disassembly, assembly, and inspection of components.

The Prohibition Safety Sign indicates an action NOT to take in order to avoid a hazard.



The Mandatory Action Sign indicates an action that NEEDS to be taken to avoid a hazard.



TRACTOR IDENTIFICATION NUMBERS

Record your Tractor's identification numbers and key number in the spaces provided. Remove the spare key and store it in a safe place. An ignition key can be duplicated only by ordering a key blank (using your key number) and making it with one of your existing keys. The ignition switch must be replaced if all keys are lost.

The Tractor serial number ① can be found stamped on lower frame rail on the front right-hand side of the Tractor .

NOTICE

The figures below are for reference only. Your model may be slightly different.

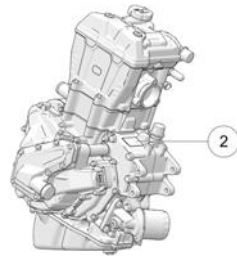

Tractor Model Number	
Tractor Identification Number (VIN) ①	
Engine Serial Number ②	
Key Number	

NEAR-FIELD COMMUNICATION (NFC) (IF EQUIPPED)

Some Tractor s come equipped with a near-field communication (NFC) chip. The NFC chip is embedded in the emblem located at the front of the Tractor and seamlessly connects you to a digital platform of Tractor information and tools. See your dealer for more information.

IMPORTANT

Not all devices are equipped with an NFC reader. Additionally, some devices require third party applications to access NFC content. For questions regarding the NFC reader on your device, refer to the device's user manual.

On models equipped with NFC, place your smartphone directly over the emblem to do the following:

- View Tractor - specific information
- Access your Garage
- Download and view the owner's manual
- View accessory instructions
- Watch how-to videos
- Access warranty information
- Check for service notifications



RIDE COMMAND WITH NFC

Additional NFC features are available when using the Ride Command mobile app. To access these features, do the following:

1. Download the Ride Command mobile app from the Apple App Store® or Google Play® store.
2. Create or log in to an existing account.
3. From the Ride Command mobile app home screen, select **Add Tractor** .
4. On the Tractor , tap the NFC-enabled badge with the phone to scan the Tractor .
5. Confirm information, name your Tractor , and tap add to garage.

SYSTEM REQUIREMENTS

Refer to device manufacturer's instructions to verify NFC read capability, and/or NFC-capable add-ons.

SAFETY

SAFETY WARNING

As the operator of the Tractor , you are responsible for your personal safety, the safety of others (including your passenger), and the protection of our environment. Read and understand your owner's manual, which includes valuable information about all aspects of your Tractor , including safe operating procedures.

Ride responsibly. Know all laws and regulations concerning the operation of this Tractor in your area.

Failure to follow the warnings in this manual can result in serious injury or death. This Tractor is not a toy and can be hazardous to operate. A collision or rollover can occur quickly, even during routine maneuvers, if you fail to take proper precautions.

Read and understand your owner's manual and all warnings before operating this Tractor .

SAFETY TRAINING

Safety training is a top priority. We strongly encourage you and any family members who will be riding this Tractor to take a training course.

For more information about safety, contact an authorized dealer or visit the Egimotors web site at: <https://egimotors.it>.

Your Tractor is considered a Tractor, please familiarize yourself with all laws and regulations concerning the operation of this Tractor in your area.

We strongly advise you to strictly follow the recommended maintenance program outlined in your owner's manual. This preventive maintenance program is designed to ensure that all critical components on your Tractor are thoroughly inspected at specific intervals.

RESTRICTIONS

Towing is approved based on the specification write inside the Owners Manual in the Towing section, read carefully and understand how to operate.

Remember that towing can be dangerous if not done in the proper way.

EQUIPMENT MODIFICATIONS

Your Tractor is designed to provide safe operation when used as directed. Modifications to your Tractor may negatively impact Tractor stability. Failure of critical machine components may result from operation with any modifications, especially those that increase speed or power. This Tractor may become less stable at speeds higher than those for which it is designed. Loss of control may occur at higher speeds.

Do not install any non-approved accessory or modify the Tractor for the purpose of increasing speed or power. Any modifications or installation of non-approved accessories could create a substantial safety hazard and increase the risk of bodily injury.

Egimotors / Polaris limited warranty on your Tractor will be terminated if any non-approved equipment and/or modifications have been added to the Tractor that increase speed or power.

The addition of certain accessories, including (but not limited to) mowers, blades, tires, sprayers, or large racks, may change the handling characteristics of the Tractor. Use only approved accessories, and familiarize yourself with their function and effect on the Tractor.

SAFE RIDING GEAR

Always wear helmet, eye protection, gloves, long-sleeve shirt, long pants, and over-the-ankle boots at all times. Protective gear reduces the chance of injury.

- ① Helmet
- ② Eye Protection
- ③ Long Sleeves
- ④ Gloves
- ⑤ Long Pants
- ⑥ Over-the-Ankle Boots



HELMET

Wearing a helmet can prevent a severe head injury. Whenever riding this Tractor, always wear a helmet that meets or exceeds established safety standards.

Clasp the buckle and pull each strap tight to ensure the helmet is properly secured to the head.

Parents should verify that young operators have a helmet that fits, and should obtain one of proper size if it does not fit before allowing operation.

Use only Approved helmets by the Department of Transportation .

Approved helmets in Europe, show an ECE 22.05 label.

The ECE mark consists of a circle surrounding the letter E, followed by the distinguishing number of the country which has granted approval. The approval number and serial number will also be displayed on the label.

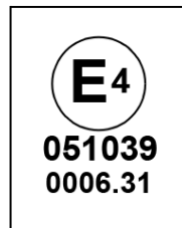

EYE PROTECTION

Do not depend on eyeglasses or sunglasses for eye protection. Whenever riding this Tractor , always wear shatterproof goggles or use a shatterproof helmet face shield.

We recommend wearing approved Personal Protective Equipment (PPE) bearing markings CE. Make sure protective eye wear is kept clean.

GLOVES

Wear gloves for comfort and for protection from sun, cold weather and other elements.

BOOTS

Wear sturdy over-the-ankle boots for support and protection. Never ride one of our Tractor s with bare feet or sandals.

CLOTHING

Wear long sleeves and long pants to protect arms and legs.

SAFETY WARNINGS

WARNING

Failure to operate this Tractor properly can result in a collision, loss of control, accident, or rollover, which may result in serious injury or death.

Heed all safety warnings outlined in this section of the owner's manual. See the operation section of this owner's manual for proper operating procedures.

OPERATING WITHOUT INSTRUCTION

Operating this Tractor without proper instruction increases the risk of an accident. The operator must understand how to operate the tractor properly in different situations and on different types of terrain.

Beginning and inexperienced operators should complete the recommended safety training before operating this Tractor .

Never permit a guest to operate the Tractor unless the guest has read this manual and all product labels and has completed a certified safety training course.



AGE RESTRICTIONS

This Tractor is an **ADULT TRACTOR ONLY**. Operation is prohibited for anyone under 16 years of age without a specific license.

Never allow anyone under 12 years of age to ride as a passenger on a 2-up Tractor.

Even though a child may be within the recommended age group for operating Tractors, they may not have the skills, abilities, or judgment needed to operate or ride on this Tractor safely and could be susceptible to accident or injury.



USING ALCOHOL OR DRUGS

Never consume alcohol or drugs before or while operating this Tractor .

Operating this Tractor after consuming alcohol or drugs could adversely affect operator judgment, reaction time, balance and perception.



FAILURE TO INSPECT BEFORE OPERATING

 **WARNING**

Failure to inspect and verify that the Tractor is in safe operating condition before operating increases the risk of an accident.

Always perform the pre-ride inspection before each use of your Tractor to make sure it's in safe operating condition.

Always follow the inspection and maintenance procedures and schedules described in this owner's manual.

HANDLING GASOLINE

Gasoline is highly flammable and explosive under certain conditions.

- Always exercise extreme caution whenever handling gasoline.
- Always refuel with the engine stopped, and outdoors or in a well ventilated area.
- Never carry fuel or other flammable liquids on this Tractor . Failure to follow this instruction could lead to serious burn injuries or death.
- Do not smoke or allow open flames or sparks in or near the area where refueling is performed or where gasoline is stored.
- Do not overfill the tank. Do not fill the tank neck.
- If gasoline spills on your skin or clothing, immediately wash it off with soap and water and change clothing.
- Always have an extinguisher available when refueling next to you

EXPOSURE TO EXHAUST

 **CAUTION**

Engine exhaust fumes are poisonous and can cause loss of consciousness or death in a short time. Never start the engine or let it run in an enclosed area. Operate this Tractor only outdoors or in well-ventilated areas.

PROTECTIVE APPAREL

Riding in this Tractor without wearing an approved helmet and protective eye wear increases the risk of a serious injuries in the event of an accident.

Always wear a helmet, eye protection, gloves, long-sleeve shirt, long pants and over-the-ankle boots.



CARRYING MORE THAN ONE PASSENGER ON A 2-UP ATV

Carrying more than one passenger on a 2-up Tractor greatly reduces the operator's ability to balance and control the Tractor, which may result in an accident or rollover. Never carry more than one passenger on a 2-up Tractor.



OPERATING ON PUBLIC ROADS

Operating this Tractor on mayor public streets could result in a collision with another Tractor.

Never operate this Tractor on highway see your locals law concerning the category of your Tractor and where you can use it.

Tractor are allowed only on secondary road.

OPERATING AT EXCESSIVE SPEEDS

Operating this Tractor at excessive speeds increases the operator's risk of losing control. Always operate at a speed that's appropriate for the terrain, the visibility and operating conditions and your skills and experience.



PHYSICAL CONTROL OF THE TRACTOR

Removing even one hand or foot can reduce ability to control the Tractor or could cause loss of balance and ejection from the ATV.

If a person's feet are not firmly planted on the footrests, they could come into contact with the wheels or other moving parts and lead to accident or injury.

Always keep both hands on the handlebars and both feet on the footrests of the ATV during operation.

TURNING IMPROPERLY



Turning improperly could cause loss of traction, loss of control, accident or rollover. Always follow proper procedures for turning as described in this owner's manual.

Avoid sharp turns. Never turn while applying heavy throttle. Never make abrupt steering maneuvers. Practice turning at slow speeds before attempting to turn at faster speeds.

JUMPS AND STUNTS

Exhibition driving increases the risk of an accident or rollover. **DO NOT** do power slides, "donuts", jumps or other driving stunts. Avoid exhibition driving.



IMPROPER HILL CLIMBING

Improper hill climbing could cause loss of control or rollover. Always follow proper procedures for climbing hills as described in the owner's manual. Always engage ADC driveline mode (if equipped) before ascending or descending a hill.

DESCENDING HILLS IMPROPERLY

Improperly descending a hill could cause loss of control or rollover. Always follow proper procedures for traveling down hills as described in this owner's manual. See the New Operator Driving Procedures section for details.

CROSSING HILLSIDES

Driving on a sidehill is not recommended. Improper procedure could cause loss of control or rollover. Avoid crossing the side of any hill unless absolutely necessary.

If crossing a hillside is unavoidable, always follow proper procedures as described in this owner's manual. See the New Operator Driving Procedures section for details.

STALLING WHILE CLIMBING A HILL

Stalling, rolling backwards or improperly dismounting while climbing a hill could cause a rollover.

- Always maintain a steady speed when climbing a hill.
- Always engage ADC mode (if equipped) before ascending or descending a hill. If ADC mode is not equipped, apply AWD mode before ascending or descending a hill.



If all forward speed is lost:

- Lean forward to keep body weight uphill. A passenger should also lean uphill.
- Apply the brakes.
- Lock the parking brake when fully stopped.
- Dismount on the uphill side of the Tractor, or on the left if the Tractor is pointing straight uphill. Have a passenger dismount first, then the operator may dismount.
- Turn the Tractor around and remount, following the procedure described in the owner's manual.

If the Tractor begins rolling downhill:

- Keep operator and passenger body weight uphill.
 - Never apply engine power.
 - Apply the brake lever gradually.
 - When fully stopped, apply the auxiliary brake as well, and then lock the parking brake.
 - Dismount on the uphill side of the Tractor, or on the left if the Tractor is pointing straight uphill. Have a passenger dismount first, then the operator may dismount.
 - Turn around and remount, following the procedure described in the owner's manual.
-

OPERATING ON STEEP HILLS

Operating on excessively steep hills could cause an overturn.

Never operate on hills too steep for the ATV or for your abilities.

Never operate this ATV on hills steeper than 15 degrees.



OPERATING ON SLIPPERY TERRAIN

Failure to use extra caution when operating on excessively rough, slippery or loose terrain could cause loss of traction, loss of control, accident or overturn.

Do not operate on excessively rough, slippery or loose terrain until you've learned and practiced the skills necessary to control the Tractor on such terrain.

Always use extra caution on rough, slippery or loose terrain.



OPERATING IN UNFAMILIAR TERRAIN

Failure to use extra caution when operating on unfamiliar terrain could result in an accident or rollover.

Unfamiliar terrain may contain hidden rocks, bumps, or holes that could cause loss of control or rollover.

Travel slowly and use extra caution when operating on unfamiliar terrain. Always be alert to changing terrain conditions.

IMPROPER TIRE MAINTENANCE

Operating this Tractor with improper tires or with improper or uneven tire pressure could cause loss of control or accident.

Always use the size and type of tires specified for your Tractor .

Always maintain proper tire pressure as described in the owner's manual and on safety labels.



OPERATING IMPROPERLY IN REVERSE

Improperly operating in reverse could result in a collision with an obstacle or person. Always follow proper operating procedures as outlined in this manual. See the New Operator Driving Procedures section for details.

Before shifting into reverse gear, always check for obstacles or people behind the Tractor . When it's safe to proceed, back slowly.

OPERATING OVER OBSTACLES

Improperly operating over obstacles could cause loss of control or rollover.

Before operating in a new area, check for obstacles. Avoid operating over large obstacles such as large rocks and fallen trees. Always follow the proper procedures outlined in this manual when operating over obstacles. See the New Operator Driving Procedures section for details.



SKIDDING OR SLIDING

Failure to use extra caution when operating on excessively rough, slippery or loose terrain could cause loss of traction, loss of control, accident or rollover. Do not operate on excessively slippery surfaces. Always slow down and use additional caution when operating on slippery surfaces.

Skidding or sliding due to loss of traction can cause loss of control or rollover (if tires regain traction unexpectedly). Always follow proper procedures for operating on slippery surfaces as described in this owner's manual. See the New Operator Driving Procedures section for details.



OPERATING A DAMAGED TRACTOR

CAUTION

Operating a damaged Tractor can result in an accident. After any rollover or other accident, have a qualified service dealer inspect the entire machine for possible damage, including (but not limited to) brakes, throttle, and steering systems.

OPERATING THROUGH WATER

Operating through deep or fast-flowing water can cause loss of traction, loss of control, rollover or accident. Never operate in fast-flowing water or in water that exceeds the floor level of the Tractor .

Always follow proper procedures for operating in water as described in this owner's manual.

Wet brakes may have reduced stopping ability. After leaving water, test the brakes. Apply them lightly several times while driving slowly. The friction will help dry out the pads.

IMPROPER CARGO LOADING

Overloading the Tractor or carrying cargo improperly may cause changes in stability and handling, which could cause loss of control or an accident.

- Always follow the instructions in this owner's manual for carrying cargo.
- Never exceed the stated load capacity for this Tractor .
- Cargo should be properly distributed and securely attached.
- Reduce speed when carrying cargo or pulling a trailer. Allow a greater distance for braking.

OPERATING ON FROZEN BODIES OF WATER

Severe injury or death can result if the Tractor and/or the operator fall through the ice. Never operate the Tractor on a frozen body of water unless you have first verified that the ice is sufficiently thick to support the weight and moving force of the Tractor , you and your cargo, together with any other Tractor s in your party.

Always check with local authorities and residents to confirm ice conditions and thickness over your entire route. Tractor operators assume all risk associated with ice conditions on frozen bodies of water.

POOR VISIBILITY



Operating this Tractor in darkness or inclement weather could result in a collision or accident, especially if operating on a road or street. Use caution and drive at reduced speeds in conditions of reduced visibility such as fog, rain and darkness. Clean headlights frequently and replace burned out headlamps promptly.

PHYSICAL SKILLS

Safe operation of this rider-active Tractor requires good judgement and physical skills. Persons with cognitive or physical disabilities who operate this Tractor have an increased risk of overturn and loss of control.

HOT EXHAUST SYSTEMS

 **WARNING**

Exhaust system components are very hot during and after use of the Tractor . Hot components can cause burns and fire. Do not touch hot exhaust system components. Always keep combustible materials away from the exhaust system.

Use caution when traveling through tall grass, especially dry grass and when traveling through muddy conditions. Always inspect the underside of the Tractor and areas near the exhaust system after driving through tall grass, weeds, brush, other tall ground cover, and muddy conditions. Promptly remove any grass, debris or foreign matter clinging to the Tractor and pay particular attention to the exhaust system area.

UNAUTHORIZED USE OF THE TRACTOR

Leaving the keys in the ignition can lead to unauthorized use of the Tractor by someone under the age of 16, without a drivers license, or without proper training. This could result in an accident or rollover. Always remove the ignition key when the Tractor is not in use.

TRAILER HITCH WARNING (IF EQUIPPED)

If using a hitch, ensure the receiver does not exceed a two inch drop or raise.

 **WARNING**

When trailering with your Tractor , be aware that the exhaust is located above the hitch ball receiver and the trailer hitch. During operation of the Tractor , the exhaust will produce hot exhaust gas that should not be inhaled and that may elevate the surface temperature of surrounding surfaces, including trailer surfaces (e.g., trailer hitch, trailer tongue, trailer walls, . . . etc.). To reduce the risk of inhaling exhaust gases and to avoid risk of burn or injury, shut off your engine and allow time for the exhaust gases to dissipate and for the surfaces surrounding the exhaust to cool, including the trailer surfaces, before connecting or disconnecting a trailer. To reduce the potential for the trailer hitch or trailer tongue from getting too hot, do not use a receiver hitch with a rise of more than two inches.

SAFETY LABELS AND LOCATIONS

Warning labels have been placed on the Tractor for your protection. Read and follow the instructions of the labels on the Tractor carefully. If any of the labels depicted in this manual differ from the labels on your Tractor, always read and follow the instructions of the labels *on the Tractor*.

If any label becomes illegible or comes off, contact your Egimotors/POLARIS dealer to purchase a replacement. Replacement *safety* labels are provided at no charge. The part number is printed on the label.

NOTE

The images below are for reference only. Your model may differ slightly.

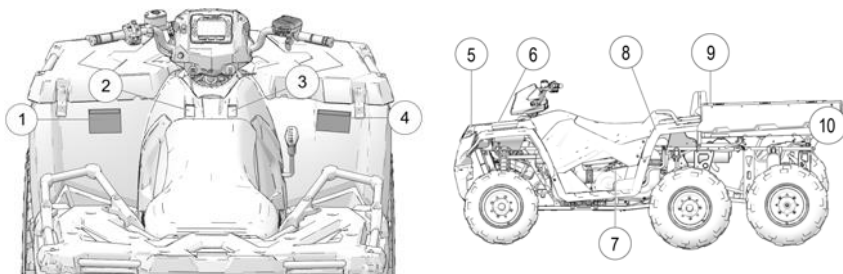

SPORTSMAN 570 6X6 SAFETY LABEL LOCATIONS

- | | |
|------------------------|--|
| ① General Alert | ⑥ Radiator Cap Warning (inside storage area) |
| ② Override Alert | ⑦ Clutch Cover Alert |
| ③ 4X4 (AWD) Alert | ⑧ Tire Pressure/Load Alert |
| ④ Hill Operation Alert | ⑨ Box Alert (inside box) |
| ⑤ Rack Alert | ⑩ Hitch Capacity Alert |

GENERAL ALERT**⚠ WARNING**

Before you operate this Tractor , read the owner's manual.

NEVER allow anyone under 16 years of age to operate this Tractor .

Wear approved helmet, goggles, and protective clothing.

NEVER use alcohol or drugs before or while operating.

NEVER carry more than 1 passenger less than 18 Years of age.

NEVER operate the Tractor on ,highways.

DISCRETIONARY ALERT**⚠ WARNING**

Read and understand your owner's manual. Never operate this Tractor on HILLS steeper than 15°.



4X4 (AWD) ALERT

WARNING

Do not push switch to engage 4X4 (AWD) if the rear wheels are spinning. This may cause severe drive shaft and clutch damage.



OVERRIDE ALERT

WARNING

Improper use of override button can lead to loss of control resulting in severe injury or death. Do not activate override while throttle is engaged. Always apply throttle gradually while in reverse.



CLUTCH COVER ALERT

WARNING

Keep body parts away from belt.



HITCH CAPACITY ALERT**⚠ WARNING**

Read the Owners Manual in the Specific section about Hitch Capacity

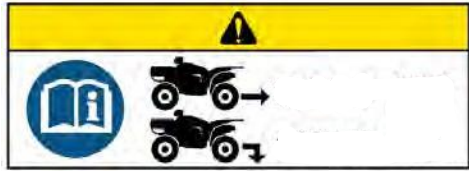
**RACK ALERT****⚠ WARNING**

DO NOT TOW FROM RACK OR BUMPER. Tractor damage or tipover may result causing severe injury or death. Tow only from tow hooks or hitch.

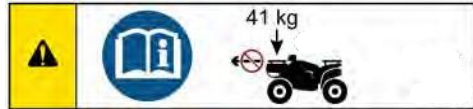
**TIRE PRESSURE ALERT****⚠ WARNING**

Read the owner's manual.
TIRE PRESSURE in Bar :
FRONT – 1 bar
CENTER - 1 bar
REAR – 1 bar

BOX ALERT**WARNING**

Read Owner's Manual. Remove flammable material containers from box before filling. Never carry passengers in cargo box.

RADIATOR CAP WARNING

WARNING

Hot pressurized fluid can cause serious burns. Do not touch radiator cap when hot. Open slowly.



FEATURES AND CONTROLS

MAIN CONTROLS

NOTICE

Image below is for reference only. Your model may differ slightly.

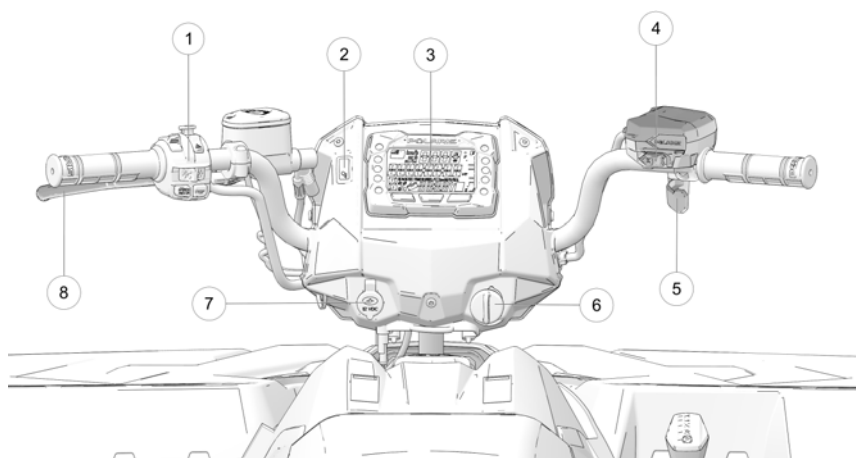



- ① Left Hand Controls
- ② Working Light Switch (if equipped)
- ③ Instrument Cluster
- ④ Driveline Mode Switch
- ⑤ Throttle Switch
- ⑥ Ignition Switch
- ⑦ Auxiliary Outlet
- ⑧ Brake Lever

IGNITION SWITCH

 **WARNING**

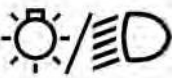
Do not attach a large key fob or key ring to the main switch. It may contact the gas tank cap when turning, causing an interruption to the electrical system and an unexpected engine shut-down during operation. This could result in serious injury or death.

SWITCH POSITION	FUNCTION
	<p>End all electrical power to the Tractor</p>
	<p>The LIGHTS ON position turns the headlights on. The engine stop switch must be in the RUN position.</p>
	<p>Start the engine. The headlights are not on in this position.</p>
	<p>After starting the engine, release the key switch to the PARKING LIGHTS ON position. The parking lights and taillights are on in this position.</p>

LEFT HAND CONTROLS

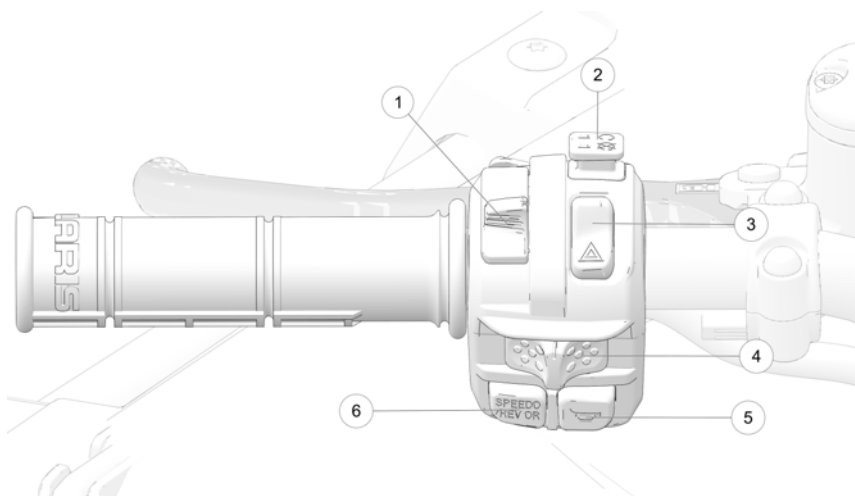

① Light Switch

② Engine Stop Switch

③ Hazard Switch

④ Turn Signal Switch

⑤ Horn Switch

⑥ Override Switch



ENGINE STOP SWITCH

NOTICE

The engine will not start or run when the switch is in the OFF position.

Push the stop switch down to stop the engine quickly. Pull the stop switch up to the RUN position before attempting to start the engine.

Both the main switch and the engine stop switch will shut off all electrical power to the Tractor , including lights.

SWITCH POSITION	FUNCTION
	OFF
	RUN

HAZARD WARNING SWITCH

Push the hazard warning switch to cause all turn signal lights to flash simultaneously. Use this feature to alert others of an emergency or other situation requiring caution.

HORN SWITCH

Press the horn switch to sound the horn.

MODE / REVERSE OVERRIDE SWITCH

This Tractor is equipped with a reverse speed limiter system. To gain additional wheel speed while backing, release the throttle and depress the override switch.

WARNING

Pressing the override switch while the throttle is open can cause loss of control, which may result in serious injury or death. Always release the throttle before pressing the override switch.



The reverse override switch also acts as a MODE button when held down for approximately one half second. The transmission cannot be in reverse when using the override switch as a MODE button.

TURN SIGNAL SWITCH

Push the toggle switch either left or right to activate the corresponding turn signal light. The indicator in the gauge will also flash. Return the toggle to the center position and push it inward to end the signal.

HEADLIGHT AND MOMENTARY HIGH BEAM SWITCH

The lights do not operate unless the main key switch is on and the engine stop switch is in the RUN position.

SWITCH POSITION	FUNCTION
	High Beam
	Low Beam

Press this switch with your left forefinger to activate the headlight high beam. The lights will return to low beam when the switch is released.

RIGHT-HAND CONTROL THROTTLE LEVER

WARNING

Operating a Tractor with sticking or improperly operating throttle controls could cause an accident. Never start or operate the Tractor that has a sticking or improperly operating throttle. Immediately contact your dealer or other qualified person for service if throttle problems arise.

Failure to check or maintain proper operation of the throttle system can result in an accident if the throttle lever sticks during operation. Always check the lever for free movement and return before starting the engine. Also check occasionally during operation.

Engine speed and Tractor movement are controlled by pressing the throttle lever . The throttle lever is spring loaded. Engine speed returns to idle when the lever is released.

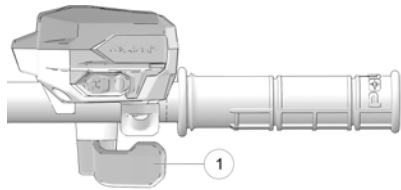

WARNING

Modifications to the electronic throttle control could result in failure to perform as designed, which could result in an accident. Do not attempt to modify the throttle control system or replace it with any after market throttle mechanisms.

DRIVELINE MODE SWITCH

The driveline mode switch  controls the All Wheel Drive (AWD) system. Use this switch to change the driveline modes between Turf Mode, 2WD, AWD, and ADC. The Tractor automatically engages AWD when operating in reverse if the driveline mode is set to AWD.

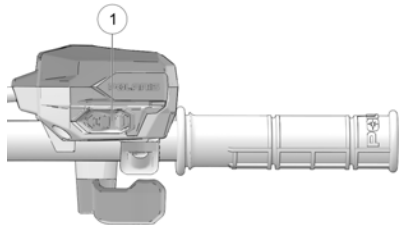

BRAKE LEVER

WARNING

Operating the ATV with a spongy brake lever can result in loss of braking, which could cause an accident. Never operate the ATV with a spongy-feeling brake lever. Always contact your dealer for service before operating the Tractor .

Squeeze the brake lever ① toward the handlebar to apply the front and rear brakes. These brakes are hydraulically activated disc type brakes that are activated by only one lever. Always test brake lever travel and master cylinder fluid level before riding. When squeezed, the lever should feel firm. Any sponginess would indicate a possible fluid leak or low master cylinder fluid level, which must be corrected before riding. Contact your dealer or other qualified service facility for proper diagnosis and repairs.

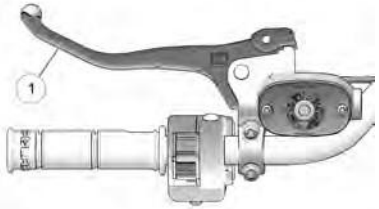

PARKING BRAKE

LOCKING THE PARKING BRAKE

WARNING

Operating the Tractor while the parking brake is engaged could result in an accident or fire. Always check to be sure the parking brake is disengaged before operating.

1. Place the transmission in PARK.
2. Squeeze and release the brake lever ① two or three times, then squeeze and hold.
3. Push the parking brake lock ② forward to engage the lock.
4. Release the brake lever.
5. To release the parking brake lock, squeeze and release the brake lever. It will return to its unlocked position.

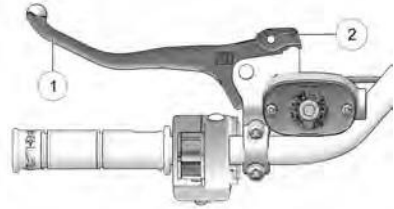

The parking brake may relax if left on for a long period of time. Always block the wheels to prevent rolling. Always block the wheels on the downhill side of the Tractor if leaving it parked on a hill. Another option is to park the Tractor in a sidehill position. Never depend on the parking brake alone if the Tractor is parked on a hill. Always block the wheels to prevent rolling.

AUXILIARY FOOT BRAKE

WARNING

Never back down a hill. Applying the auxiliary brake when backing down a hill may cause rear tipover, which could result in serious injury or death. Use caution when applying the auxiliary brake.

The auxiliary brake system is intended to be used as a backup for the main brake system. Should the main system fail, use the auxiliary foot brake. The auxiliary foot brake ① is located on the inside of the right footrest. Operate this brake with your right foot. If the rear wheels slide while using the auxiliary brake, *reduce* brake pedal pressure to brake the rear wheels without skidding.

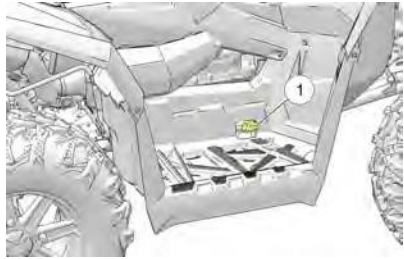

NOTICE

If service brake system is fully functioning, the auxiliary foot brake will brake on all wheels. The auxiliary brake can be used when starting the Tractor . To start the Tractor using the auxiliary foot brake, depress the foot brake and turn the ignition key to the start position.

BRAKE FLUID LEVEL

Check the brake fluid level frequently for the auxiliary brake system. The reservoir is located under the seat.

Maintain the fluid level between the maximum and minimum marks. Use DOT 4 brake fluid only.

MIRRORS (IF EQUIPPED)

Use the mirrors to assist in traffic maneuvers. Always check and adjust the mirrors before driving the Tractor .

FUEL CAP

This Tractor is equipped with a digital fuel gauge that will indicate a low fuel condition. Refuel when the gauge indicates a low fuel condition.

Always refuel with the engine stopped, and outdoors or in a well ventilated area. Refuel on a level surface.

Have always a fire extinguisher ready for use.

Remove the fuel tank cap to add fuel to the fuel tank.

Do not use fuel with ethanol content greater than 10 percent.



EXTREME USE BATTERY

An optional extreme use battery may be available for your model. If the performance of the factory-installed battery is inadequate due to operation in extreme cold or due to extended use of multiple electrical accessories, your P dealer can assist.

Your dealer can provide any installation procedures that may differ for an extreme use battery.

BATTERY CHARGE PORT

Your Tractor is equipped with a battery charge port ①. The battery charge port allows you to quickly and easily connect a battery charger to your Tractor's battery.



ELECTRONIC POWER STEERING (EPS)

Electronic power steering (EPS), if equipped, engages when the ignition key is turned to the ON position. EPS remains engaged whether the Tractor is moving or idle. See the Instrument Cluster section for EPS Warning Indicator information.

NOTICE

Never switch EPS modes while the Tractor is in motion. Ensure the Tractor is fully stopped and no force is applied to the steering system before switching EPS modes.

EPS has three modes: high, medium, low. To set the EPS mode, do the following.

1. Stop the Tractor and put it in PARK.
2. Press and hold the MODE button to enter the Options Menu. "OPTIONS" will display on the screen for 3 seconds before showing the first menu item.
3. Select "EPS" from the Options Menu by pressing the MODE button.
4. Toggle the Up/Down Buttons to choose between the high, medium, and low modes.
5. Press the MODE button to lock in the EPS setting.



SEAT SEAT REMOVAL

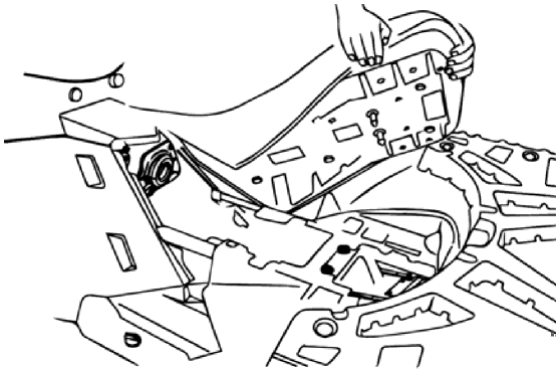

1. Locate the seat removal latch in the center of the seat's rear.
2. Pull on the latch handle to disengage the seat from the Tractor 's frame.
3. Remove the seat.

HITCHES

See the Specifications Section for hitch weight capacities.

NOTICE

Do not tow a Tractor or a trailer with this Tractor unless all instructions have been followed. See the Hauling Cargo section for details.

CAUTION

Whenever the Tractor is towing, always stay clear of the area between the Tractor and the towed object.

HITCH REMOVAL / INSTALLATION

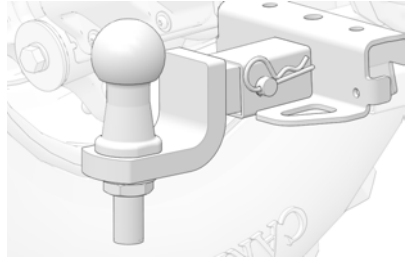
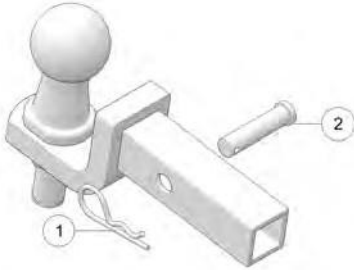

1. To remove the hitch (if equipped), remove the cotter pin ① and hitch pin ②. Remove the hitch, then reinstall the hitch pin ② and secure the cotter pin ①.
2. To install the hitch, remove the cotter pin ① from the hitch pin and remove the hitch pin ②.
3. Install the hitch to the receiver.
4. Reinstall the hitch pin (from the left side of the hitch) through the bore of both the receiver and the hitch.
5. Reinstall the cotter pin. Make sure the hitch assembly is secure at that the cotter pin is properly engaged over the hitch pin.

AUTOMATIC TRANSMISSION GEAR SELECTOR

The transmission gear selector ① is located on the right side of the Tractor . To shift gears, brake to a complete stop. When the engine is idling, move the lever to the desired gear.

- H:** High Gear
- L:** Low Gear
- N:** Neutral
- R:** Reverse
- P:** Park

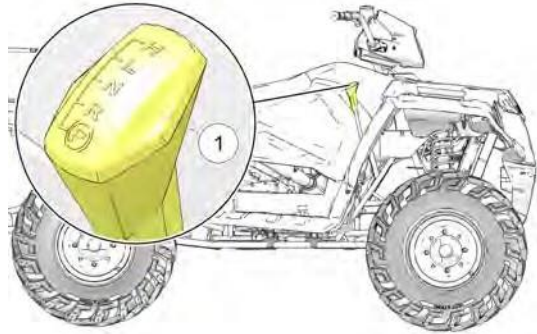

NOTE

Shifting gears with the engine speed above idle or while the Tractor is moving could cause transmission damage.

Whenever the Tractor is left unattended, always place the transmission in PARK and lock the parking brake.

BELT LIFE

To extend belt life, use low forward gear when pulling a heavy load at less than 11 km/h for extended periods and when operating uphill at a slow speed.

INSTRUMENT CLUSTER OVERVIEW

NOTICE

Features and telltales vary by model.

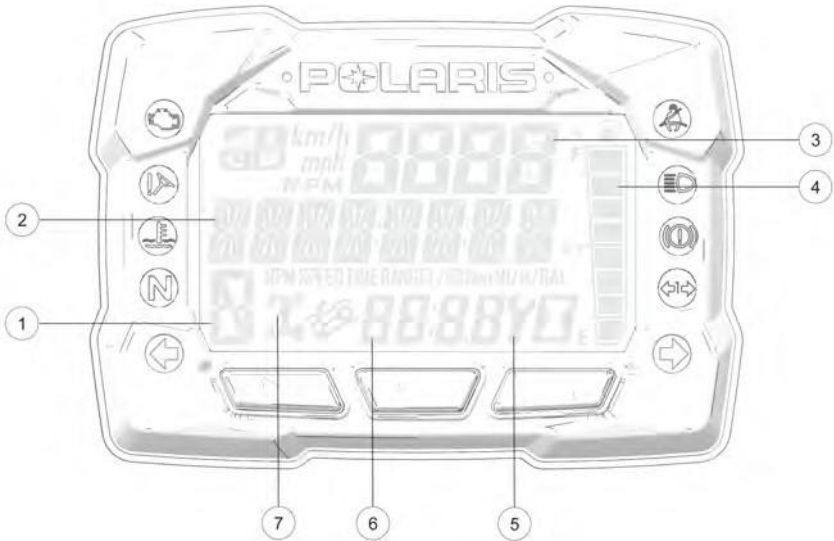





DISPLAY AREA	FUNCTION
① Gear Indicator	H = High Gear L = Low Gear N = Neutral R = Reverse Gear P = Park – = Gear Signal Error (or shifter between gears)
② Display Area 2	This area displays odometer, trip meter, trip meter 2, voltage, engine temperature, engine hour meter, programmable service hour interval, ground speed, or engine RPM.
③ Display Area 1	This area displays engine RPM, ground speed, or coolant temperature.
④ Fuel Gauge	The segments of the fuel gauge show the level of fuel in the fuel tank. When the last segment clears, a low fuel warning is activated. All segments including the fuel icon will flash. Refuel immediately.



FEATURES AND CONTROLS

DISPLAY AREA	FUNCTION
⑤ Service Indicator	A flashing wrench symbol alerts the operator that the preset service interval has been reached. Your POLARIS dealer can provide scheduled maintenance. See page 61 for more information.
⑥ Clock	The clock displays time in a 12-hour or 24-hour format.
⑦ Driveline Mode Indicator	Segments of the indicator illuminate based on driveline mode engaged.

INDICATOR LAMPS

INDICATOR	ICON	FUNCTION
Check Engine		This indicator appears if a fault occurs. Do not operate the Tractor if this warning appears. Serious engine damage could result. Your authorized POLARIS dealer can assist.
EPS Warning (if equipped)		This indicator illuminates when a fault has occurred in the EPS system. Your authorized POLARIS dealer can assist. EPS operation is possible with key on/engine off for up to 5 minutes.
Engine Hot		This lamp illuminates to indicate an overheated engine. If the indicator flashes, a severe overheating condition exists.
Neutral		This lamp illuminates when the transmission is in neutral and the ignition key is in the ON position.
Helmet/Seat Belt		This lamp flashes for several seconds when the key is turned to the ON position. The lamp is a reminder to wear helmet and seat belt (if equipped) before operating.

FEATURES AND CONTROLS

INDICATOR	ICON	FUNCTION
High Beam		This lamp illuminates when the headlamp switch is set to high beam.
Brake Failure (if equipped)		Lamp illuminates when Brake System (if Brake Failure Alarm is equipped) detects low pressure in brake hydraulic system. Verify brake fluid in reservoirs.
Trailer Indicator		The Turn Trailer Indicator is illuminating when the trailer turn signals are active.

DISPLAY AREA 1

Pressing the MODE button will change the information displayed in Area 1 ①.



DISPLAY AREA 1	FUNCTION
Speed	The Tractor 's speed will be displayed in mph, or km/h.
Engine Temperature	The Tractor 's current engine temperature will be displayed.
RPM	The Tractor 's RPM will be displayed.

DISPLAY AREA 2

Toggle the Up/Down buttons to change the information displayed in Area 2 ②.



DISPLAY AREA 2	FUNCTION
Odometer	The Tractor 's odometer reading will be displayed.
Engine Temperature	The Tractor Engine Temperature will be displayed.
Trip 1	The Tractor Trip 1 mileage will be displayed.
Trip 2	The Tractor Trip 2 mileage will be displayed.
RPM	The Tractor RPM will be displayed.
Voltage	The Tractor 's current battery voltage will be displayed.
Speed	The Tractor 's current speed will be displayed.
Engine Hours	The Tractor 's engine hours will be displayed.
Service Hours	The Tractor 's service hours will be displayed.

OPTIONS MENU



Press and hold the MODE button to enter the Options Menu.

OPTIONS MENU	NOTES
Electronic Power Steering (EPS) (if equipped)	Select between low, medium, or high levels of power steering assistance.
Diagnostic Codes	Only displays if fault codes are present or stored
Units - Distance	Select MPH or KPH
Units - Temp	Select between °F and °C
Clock	Select between 12H or 24H, and set time
Backlight Color	Select between Blue or Red
Backlight Level	Set backlight brightness level
Service Hours	View/Set Service hours

FEATURES AND CONTROLS

OPTIONS MENU	NOTES
Bluetooth® Pairing (if equipped)	Pair Bluetooth® device
Exit Menu	Exit

DIAGNOSTIC CODE

Diagnostic Code Screen will show available MIL that has come on during that ignition cycle.

To access the Diagnostic Code Screen, do the following:

1. Press and hold the MODE button to enter the Options Menu. "OPTIONS" will display on the screen for 3 seconds before showing first menu item.



2. Select "Diagnostic Codes" from the Options Menu by pressing the MODE button.

Toggle the Up/Down Buttons to cycle through Code(s).

NOTICE

This option will only be available if a fault code was set or is active during the current ignition key 'on' cycle. Turning off the ignition will clear any save fault codes from the gauge.

- ① Display area 1 will show FMI
- ② Display area 2 will show SPN
- ③ Clock Area will show Count.



NOTICE

When the gauge is displaying a fault code, the warning telltale (check engine or EPS) will blink to indicate which controller set the fault code.

- To exit the Options Menu the user can select Exit Menu function from Options Menu, can hold Mode Button and exit out of Options Menu, or not press any button for 10 seconds, which will exit out of the Options Menu.

UNIT SELECTION DISTANCE

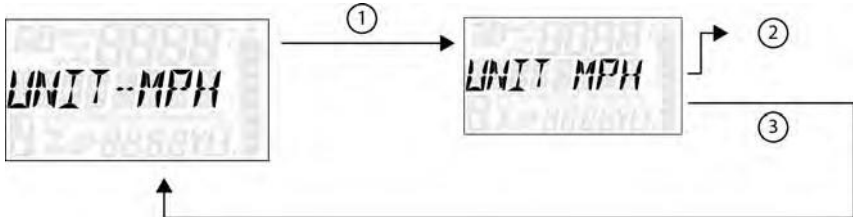

- Press and hold the MODE button to enter the Options Menu.

NOTICE

"OPTIONS" will display on the screen for 3 seconds before showing first menu item.

- Select "Units-Distance" from the Options Menu by pressing the MODE button.

Reference the image shown above:

- Press the MODE button.
 - Toggle the Up/Down Buttons to change the units (MPH or KPH)
 - With the correct unit displayed, Press the mode button which will set the unit and return to the Options Menu.
- To exit the Options Menu the user can select Exit Menu function from Options Menu, can hold Mode Button and exit out of Options Menu, or not press any button for 10 seconds, which will exit out of the Options Menu.

UNIT SELECTION TEMPERATURE

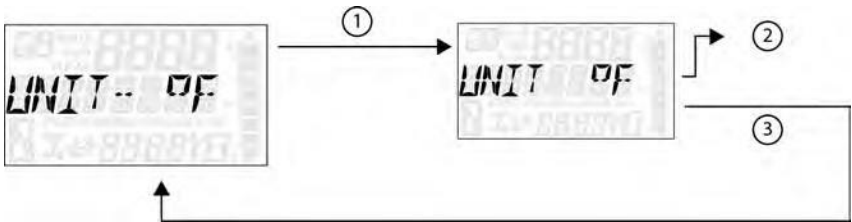

1. Press and hold the MODE button to enter the Options Menu.

NOTICE

"OPTIONS" will display on the screen for 3 seconds before showing first menu item.

2. Select "Units - Temp" from the Options Menu by pressing the MODE button.

Reference the image shown above:

- ① Press the MODE button.
- ② Toggle the Up/Down Buttons to change the units (°F or °C)
- ③ With the correct unit displayed, Press the mode button which will set the unit and return to the Options Menu.

3. To exit the Options Menu the user can select Exit Menu function from Options Menu, can hold Mode Button and exit out of Options Menu, or not press any button for 10 seconds, which will exit out of the Options Menu.

CLOCK

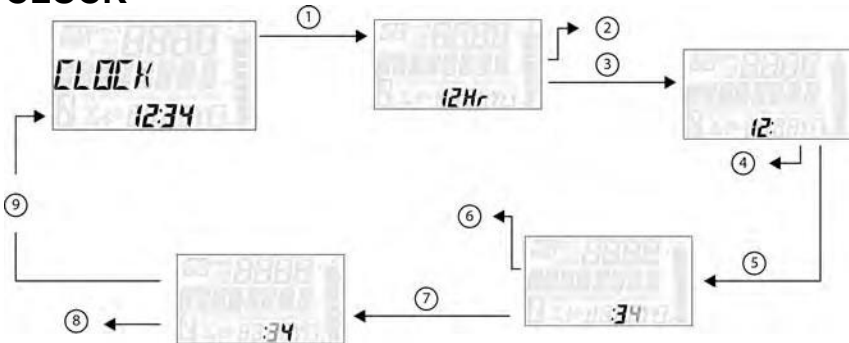

1. Press and hold the MODE button to enter the Options Menu.

NOTICE

"OPTIONS" will display on the screen for 3 seconds before showing first menu item.

2. Select "Clock" from the Options Menu by pressing the MODE button.

Reference the image shown above:

- ① Press the MODE button.
 - ② Toggle the Up/Down Buttons to change the units (12H or 24H)
 - ③ With the correct unit displayed, Press the mode button which will set the unit.
 - ④ Toggle the Up/Down Buttons to change the units (Cycles Hours)
 - ⑤ With the correct unit displayed, Press the mode button which will set the unit.
 - ⑥ Toggle the Up/Down Buttons to change the units (Cycles 10s of Minutes)
 - ⑦ With the correct unit displayed, Press the mode button which will set the unit.
 - ⑧ Toggle the Up/Down Buttons to change the units (Cycles 1s of Minutes)
 - ⑨ With the correct unit displayed. Press the mode button which will set the unit and return to the Options menu.
3. To exit the Options Menu the user can select Exit Menu function from Options Menu, can hold Mode Button and exit out of Options Menu, or not press any button for 10 seconds, which will exit out of the Options Menu.

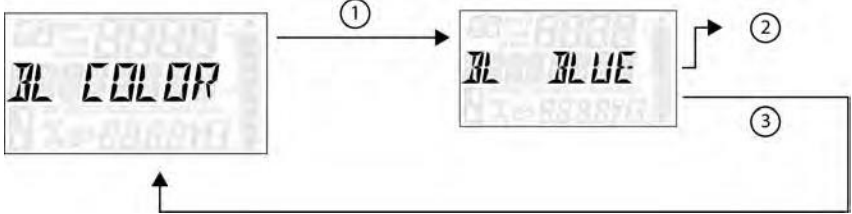
BACK LIGHT COLOR

1. Press and hold the MODE button to enter the Options Menu.

NOTICE

"OPTIONS" will display on the screen for 3 seconds before showing first menu item.

2. Select "Backlight Color" from the Options Menu by pressing the MODE button.

Reference the image shown above:

- ① Press the MODE button.
 - ② Toggle the Up/Down Buttons to change the units (Blue or Red)
 - ③ With the correct unit displayed, Press the mode button which will set the unit and return to the Options Menu.
3. To exit the Options Menu the user can select Exit Menu function from Options Menu, can hold Mode Button and exit out of Options Menu, or not press any button for 10 seconds, which will exit out of the Options Menu.

BACK LIGHT LEVEL

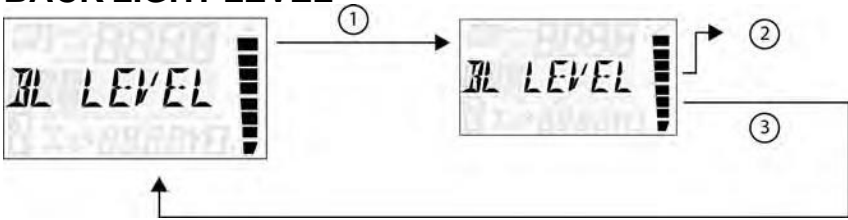

1. Press and hold the MODE button to enter the Options Menu.

NOTICE

"OPTIONS" will display on the screen for 3 seconds before showing first menu item.

2. Select "Backlight Level" from the Options Menu by pressing the MODE button.

Reference the image shown above:

- ① Press the MODE button.
 - ② Toggle the Up/Down Buttons to change the units (Increase or Decrease Level)
 - ③ With the correct unit displayed, Press the mode button which will set the unit and return to the Options Menu.
3. To exit the Options Menu the user can select Exit Menu function from Options Menu, can hold Mode Button and exit out of Options Menu, or not press any button for 10 seconds, which will exit out of the Options Menu.

SERVICE HOURS

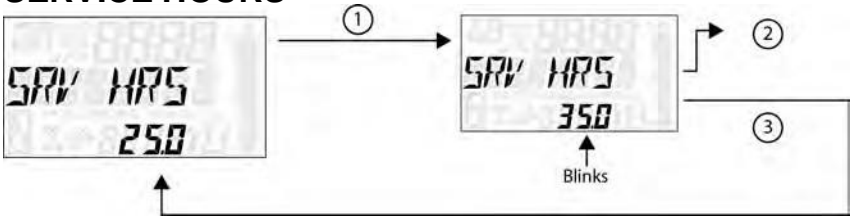

1. Press and hold the MODE button to enter the Options Menu.

NOTICE

“OPTIONS” will display on the screen for 3 seconds before showing first menu item.

2. Select “Service Hours” from the Options Menu by pressing the MODE button.

Reference the image shown above:

- ① Press the MODE button.
- ② Toggle the Up/Down Buttons to change the units (0, 5, 10 - 95, 100)
- ③ With the correct unit displayed, press the MODE button, which will set the unit and return you to the Options Menu.

NOTICE

To reset service hours after they have counted down to "0.0", reselect the existing setpoint or select a new service hour value.

3. To exit the Options Menu the user can select Exit Menu function from Options Menu, can hold Mode Button and exit out of Options Menu, or not press any button for 10 seconds, which will exit out of the Options Menu.

BLUETOOTH® (IF EQUIPPED)

The Bluetooth® functionality allows users to pair their phones with the Tractor's digital gauge. This function allows users to receive call and text alerts while operating the Tractor .

If a text message is received while the Tractor is moving faster than 2 KPH, only the sender's name is shown onscreen.

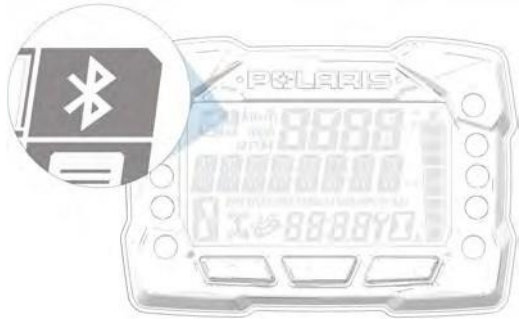

If you are browsing any of the Bluetooth® menus and the Tractor starts to move faster than 2 KPH, the menu will automatically display *TRACTOR MOVING*. If you attempt to access Bluetooth® menus while the Tractor is moving faster than 2 KPH, the screen will display *TRACTOR MOVING* momentarily, and then it will redirect to the options menu.

PAIRING YOUR PHONE TO THE GAUGE

Use the following procedure to pair your phone with the Tractor's digital gauge.

NOTICE

Bluetooth® functionality is compatible with both iOS® and Android® phones. For iOS® phones, you must go to the Settings option and enable notifications. Most Android® phones will prompt the user automatically to enable notifications as part of the pairing process.

1. Make sure Bluetooth® is enabled on your phone.
2. Access the options menu on the Tractor's digital gauge and select *BT PAIR*. The Bluetooth® icon will begin to blink.
3. Find and select *Polaris Gauge* on your phone's Bluetooth® menu or prompt. Pairing should occur momentarily. Pairing mode will continue for up to 90 seconds or if you exit the *BT PAIR* menu.

After successfully pairing the phone, the Tractor's digital gauge will automatically reconnect with the phone each time it is powered on and within range. No further action is required by the user at this point.

ALL WHEEL DRIVE SYSTEM

NOTICE

Switching to AWD while the rear wheels are spinning may cause severe drive shaft and gearcase damage. Always switch to AWD while the rear wheels have traction or are at rest.

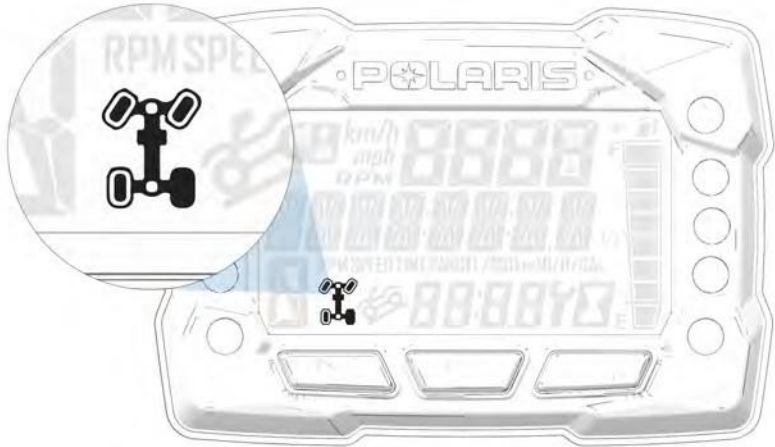

The All Wheel Drive system is controlled by the Driveline switch. See page 40. Engage AWD before getting into conditions where front wheel drive may be needed. If the rear wheels are spinning, release the throttle before switching to AWD.

AWD MODE

Move the momentary Driveline switch to the far right to engage AWD. AWD will engage when engine speed slows to below 3100 RPM. The gauge will display "AWD". There is no limit to the length of time the Tractor may remain in AWD. The Tractor automatically engages AWD when operating in reverse if the switch is set to the AWD position.



Once enabled, AWD remains enabled until the switch is turned off. If the switch is turned off while the demand drive unit is moving, it will not disengage until the rear wheels regain traction.

When in AWD, the demand drive unit will automatically engage any time the rear wheels lose traction. When the rear wheels regain traction, the demand drive unit will automatically disengage.

4X6 MODE

Move the momentary switch to the far left to operate in four-wheel drive. AWD will disengage when engine speed slows to below 3100 RPM. The gauge will display "2X4".



TURF MODE (IF EQUIPPED)

 **WARNING**

Operating in TURF mode when on sloped, uneven, or loose terrain could cause loss of control and result in serious injury or death. One rear wheel may slip and lose traction or may lift up and grab when it touches the ground again.

When operating in TURF mode, the inside rear wheel will rotate independently from the outside wheel during turns. Operate in TURF mode only as needed to protect smooth, level surfaces from tire damage. DO NOT operate in TURF mode when climbing or descending hills, when sidehilling, or when operating on uneven, loose, or slippery terrain such as sand, gravel, ice, snow, obstacles, and water crossings. Always operate in ADC 6X6 or 6X6 on these types of terrain.



FOUR-WHEEL DESCENT CONTROL (IF EQUIPPED)

NOTICE

Switching to 4WDC while the rear wheels are spinning may cause severe drive shaft and gearcase damage. Always switch to 4WDC while the rear wheels have traction or are at rest.

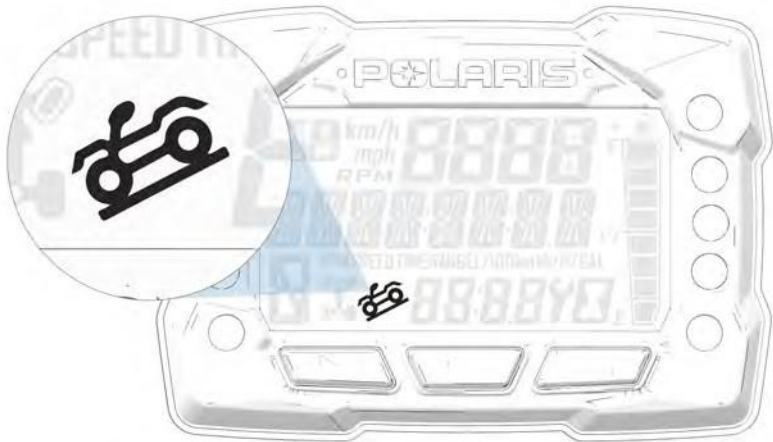

The Six -Wheel Decent Control (6WDC) system allows engine braking to all six wheels when the Tractor descends a hill or incline. Always engage 6WDC mode (if equipped) before ascending or descending a hill.

ENGAGING FOUR-WHEEL DESCENT CONTROL

The 6WDC system will automatically engage when *all* of the following conditions occur:

- 6WDC is engaged
- The throttle must be closed (throttle lever released)
- The transmission must be in gear (high, low or reverse)

DISENGAGING FOUR-WHEEL DESCENT CONTROL

The 6WDC system will automatically disengage if *at least one* of the following conditions occur:

- The 6X6 switch is moved out of the 6WDC position
- The throttle is open (throttle is applied)
- The transmission is shifted to neutral or park
- The Tractor is on flat ground, or not actively descending a hill

OPERATION

SAFE OPERATION PRACTICES

 **WARNING**

Failure to operate the Tractor properly can result in a collision, loss of control, accident or rollover, which may result in serious injury or death. Read and understand all safety warnings outlined in the safety section of this owner's manual.

1. Complete the recommended safety training at your Dealership before operating this Tractor .
2. Do not allow anyone under 16 years of age to operate this Tractor . Do not allow anyone with cognitive or physical disabilities to operate this Tractor .
3. Never carry more than one passenger on a 2-up Tractor
4. Engine exhaust fumes are poisonous. Never start the engine or let it run in an enclosed area.
5. Before operating, learn how to use the auxiliary brake for emergency situations (if service brakes become inoperable).
6. Use caution and drive at reduced speeds in conditions of reduced visibility such as fog, rain and darkness. Clean headlights frequently and replace burned out headlamps promptly.
7. Drive in a manner appropriate for your skills, your passenger's skills and operating conditions. Never operate at excessive speeds. Never attempt wheelies, jumps, or other stunts. Never remove your hands from the handlebars while operating, and always keep both feet on the footrests.
8. Never consume alcohol or drugs before or while operating.
9. Always use the size and type of tires specified for your Tractor . Always maintain proper tire pressure.
10. Never operate a damaged Tractor . After any overturn or accident, have a qualified service dealer inspect the entire machine for possible damage.
11. Never operate the ATV on a frozen body of water unless you have independently verified that the ice is sufficiently thick to support the weight and moving force of the Tractor, you and your cargo, together with any other Tractor s in your party.

12. Do not touch hot exhaust system components. Always keep combustible materials away from the exhaust system.
13. Always remove the ignition key when the Tractor is not in use to prevent unauthorized use.

TRAIL ETIQUETTE

Always practice good etiquette when riding. Allow a safe distance between your Tractor and other Tractors operating in the same area. Communicate to oncoming operators by signaling the number of Tractors in your group. When stopping, move your Tractor to the edge of the trail as far as possible to allow others to pass safely.

KNOW YOUR RIDING AREA/TREAD LIGHTLY

Familiarize yourself with all laws and regulations concerning the operation of this Tractor in your area. Respect the environment in which you ride your Tractor. Find out where the designated riding areas are by contacting your dealer, a local riding club, or local officials.

Help keep our trails open for recreational Tractor use. As an off-road enthusiast, you represent the sport and can set a good example (or a poor example) for others to follow. Operate with respect for the terrain, avoid littering, and always stay on the designated trails.

TRACTOR BREAK-IN PERIOD

The break-in period for your new Tractor is the first 25 hours of operation, or the time it takes to use the first two tanks full of gasoline. No single action on your part is as important as a proper break-in period. Careful treatment of a new engine and drive components will result in more efficient performance and longer life for these components. Perform the following procedures carefully.

NOTICE

Excessive heat build-up during the first three hours of operation will damage close-fitted engine parts and drive components. Do not operate at full throttle or high speeds during the first three hours of use.

Use of any improper oils may cause serious engine damage. POLARIS PS-4 Full Synthetic 5W-50 4-Cycle Oil is specifically formulated for your 4-cycle engine.

ENGINE AND DRIVETRAIN BREAK-IN

1. Fill the fuel tank with gasoline. See the Fuel Tank section for details. Always exercise extreme caution whenever handling gasoline.
2. Check the oil level. See the Oil Check section for reference. Add the recommended oil as needed to maintain the oil level in the safe operating range.
3. Drive slowly at first. Select an open area that allows room to familiarize yourself with Tractor operation and handling.
4. Avoid aggressive use of the brakes.
5. Vary throttle positions. Do not operate at sustained idle.
6. Pull only light loads.
7. Perform regular checks on fluid levels, controls and areas outlined on the daily pre-ride inspection checklist.
8. During the break-in period, change both the oil and the filter at 25 hours or 250 miles.
9. Check fluid levels of transmission and all gearcases after the first 25 hours of operation and every 100 hours thereafter.

BRAKE SYSTEM BREAK-IN

Apply only moderate braking force for the first 50 stops. Aggressive or overly forceful braking when the brake system is new could damage brake pads and rotors.

PVT BREAK-IN (CLUTCHES/BELT)

Always break in the clutches and drive belt of new Tractor s, as well as after a belt replacement.

A proper break-in of the clutches and drive belt will ensure a longer life and better performance. Break in the clutches and belt by operating at slower speeds during the break-in period as recommended. Pull only light loads. Avoid aggressive acceleration and high speed operation during the break-in period.

If a belt fails, always clean any debris from the PVT intake and outlet duct and from the clutch and engine compartments when replacing the belt.

PRE-RIDE CHECKLIST

Failure to inspect and verify that the ATV is in safe operating condition before operating increases the risk of an accident. Always inspect the ATV before each use to make sure it's in safe operating condition.

DRIVING PROCEDURES

NEW OPERATOR DRIVING PROCEDURES

1. Wear protective riding gear. See the Safe Riding Gear section.
2. Perform the pre-ride inspection.
3. Place the transmission in PARK.
4. Lock the brake holding latch.
5. Mount the Tractor from the left side.
6. Sit upright with both feet on the footrests and both hands on the handlebars.
7. Start the engine and allow it to warm up.
8. Shift the transmission into gear.
9. Check your surroundings and determine your path of travel.
10. Release the brake holding latch.
11. Slowly depress the throttle with your right thumb and begin driving.
12. Drive slowly. Practice maneuvering and using the throttle and brakes on level surfaces.



TURNING THE TRACTOR

Both rear wheels drive equally at all times. This means that the outside wheel must travel a greater distance than the inside wheel when turning, and the inside tire must slip traction slightly.

1. Slow down.
2. Never turn quickly when carrying cargo.
3. Steer in the direction of the turn.
4. Keep both feet on the footrests.
5. Lean your upper body to the inside of the turn while supporting your weight on the outer footrest. This technique alters the balance of traction between the rear wheels, allowing the turn to be made smoothly. The same leaning technique should be used for turning in reverse.
6. Practice making turns at slow speeds before attempting to turn at faster speeds.

**WARNING**

Turning improperly can result in Tractor overturn. Never turn abruptly or at sharp angles. Never turn at high speeds.

DRIVING ON SLIPPERY SURFACES

WARNING

Skidding or sliding can cause loss of control or rollover (if tires regain traction unexpectedly). When operating on slippery surfaces such as ice or loose gravel, reduce speed and use extra caution to reduce the chance of skidding or sliding out of control. Do not operate on excessively slippery surfaces.



Whenever riding on slippery surfaces such as wet trails or loose gravel, or during freezing weather, follow these precautions:

1. Do not operate on excessively rough, slippery or loose terrain.
2. Slow down when entering slippery areas.
3. Engage 6X6 before wheels begin to lose traction.

NOTICE

Severe damage to drive train may occur if the 4X4 is engaged while the wheels are spinning. Allow the rear wheels to stop spinning before engaging 6X6, or engage 6X6 before wheels begin to lose traction.

4. Maintain a high level of alertness, reading the trail and avoiding quick, sharp turns, which can cause skids.
5. Never apply the brakes during a skid. Correct a skid by turning the handlebars in the direction of the skid and shifting your body weight forward.

DRIVING UPHILL

Braking and handling are greatly affected when operating in hilly terrain. Improper procedure could cause loss of control or overturn. Whenever traveling uphill, follow these precautions:

1. Always engage 6WDC before ascending or descending a hill.
 2. Drive straight uphill.
 3. Avoid steep hills. **Maximum incline is: 15°**
 4. Always check the terrain carefully before ascending any hill.
 5. Never climb hills with excessively slippery or loose surfaces.
 6. Keep both feet on the footrests.
 7. Shift body weight uphill.
 8. Proceed at a steady rate of speed and throttle opening. Opening the throttle suddenly could cause the ATV to flip over backwards.
 9. Never go over the top of any hill at high speed. An obstacle, a sharp drop, or another Tractor or person could be on the other side of the hill.
 10. Remain alert and be prepared to take emergency action. This may include quick dismounting of the Tractor .
-

DRIVING DOWNHILL



When driving downhill, follow these precautions:

1. Always check the terrain carefully before descending a hill.
 2. Always engage 6WD or 6WDC mode (if equipped) before ascending or descending a hill.
 3. Avoid steep hills. **Maximum incline is 15°**
 4. Always descend a hill with the transmission in forward gear. Do not descend a hill with the transmission in neutral.
 5. Slow down. Never travel down a hill at high speed.
 6. Drive straight downhill. Avoid traveling down a hill at an angle, which would cause the Tractor to lean sharply to one side.
 7. Shift body weight uphill.
 8. Apply the brakes *slightly* to aid in slowing. Applying the brakes too firmly may cause the rear wheels to lock, which could result in loss of control.
-

DRIVING ON A SIDEHILL (SIDEHILLING)



Driving on a sidehill is not recommended. Improper procedure could cause loss of control or overturn. Avoid crossing the side of any hill unless absolutely necessary.

If crossing a sidehill is *unavoidable*, follow these precautions:

1. Slow down.
2. Avoid crossing the side of a steep hill.
3. Lean into the hill, transferring your upper body weight toward the hill while keeping your feet on the footrests.
4. If the Tractor begins to tip, quickly turn the front wheel downhill, if possible, or dismount on the uphill side *immediately!*

TURNING AROUND ON A HILL (K-TURN)

If the Tractor stalls while climbing a hill, never back it down the hill! Use the K-Turn to turn around.

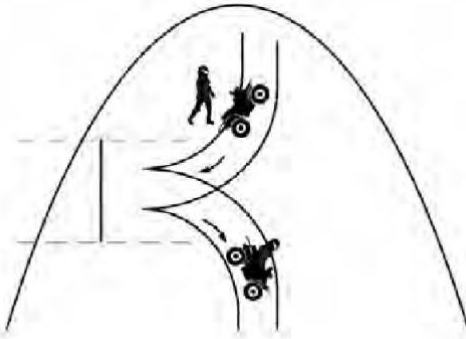

1. Stop the Tractor . Keep your weight uphill.
 2. Always engage ADC mode (if equipped) before ascending or descending a hill. If ADC mode is not equipped, apply AWD mode before ascending or descending a hill.
 3. Lock the hydraulic parking brake.
 4. Leave the transmission in forward gear. Turn the engine off.
 5. Stay uphill of the Tractor and turn the handlebars full left.
 6. Squeeze the brake lever to release the parking brake.
 7. Slowly release the brake lever and allow the Tractor to roll around to your right until it's pointing across the hill or slightly downward.
 8. Lock the hydraulic parking brake.
 9. Remount from the uphill side. Keep your weight uphill. *A passenger should not remount until the Tractor returns to firm, level ground.*
 10. Apply the foot brake.
 11. With the transmission still in forward, start the engine.
 12. Squeeze and release the brake lever to release the parking brake.
 13. Release the foot brake and drive *slowly* downhill. Control speed with either the hand or foot brake until the Tractor is on level ground.
-

DRIVING THROUGH WATER

NOTICE

Major engine damage can result if the Tractor is not thoroughly inspected after operation in water. Perform the services outlined in the Periodic Maintenance Chart. The following areas need special attention: engine oil, transmission oil, demand drive fluid and all grease fittings.

If the Tractor tips or overturns in water, or if the engine stops during or after operating in water, service is required before starting the engine. Your POLARIS dealer can provide this service. If it's impossible to bring the Tractor in before starting the engine, perform the service outlined in the Tractor Immersion section of this manual, and take the Tractor in for service at the first opportunity.

Your Tractor can operate through water with a maximum recommended depth equal to the bottom of the footrests.

Follow these procedures when operating through water:

1. Determine water depths and current before entering water.
2. Choose a crossing where both banks have gradual inclines.
3. Avoid operating through deep or fast-flowing water.



4. After leaving water, test the brakes. Apply them lightly several times while driving slowly. The friction will help dry out the pads.

If it's unavoidable to enter water deeper than the footrest level:

- Proceed slowly. Avoid rocks and obstacles.
 - Balance your weight carefully. Avoid sudden movements.
 - Maintain a steady rate of speed. Do not make sudden turns or stops. Do not make sudden throttle changes.
-

DRIVING OVER OBSTACLES



Follow these precautions when operating over obstacles:

1. Always check for obstacles before operating in a new area.
 2. Look ahead and learn to read the terrain. Be constantly alert for hazards such as logs, rocks and low hanging branches.
 3. Travel slowly and use extra caution when operating on unfamiliar terrain. Not all obstacles are immediately visible.
 4. Never attempt to operate over large obstacles, such as rocks or fallen trees.
 5. Always have a passenger dismount before operating over an obstacle that could cause a fall from the Tractor to tipover.
-

DRIVING IN REVERSE



Follow these precautions when operating in reverse:

1. Always check for obstacles or people behind the Tractor .
2. Always avoid backing downhill.
3. Back slowly.
4. Apply the brakes *lightly* for stopping.
5. Avoid turning at sharp angles.
6. Never open the throttle suddenly.
7. Do not use the override switch unless additional wheel speed is required for Tractor movement. Use the override with caution as rearward Tractor speed is greatly increased. Do not operate at wide open throttle. Operate the throttle just enough to maintain a desired speed.

NOTICE

Excessive throttle operation while in the speed limit mode may cause fuel to build in the exhaust, resulting in engine popping and/or engine damage.

OPERATING IN LIGHTNING

Avoid operating this Tractor when lightning could occur unless the Tractor is equipped with a fully enclosed cab. Rubber tires, rubber handgrips and a foam seat will not protect a rider from lightning strikes. Always seek safe shelter when lightning is imminent.

STARTING THE ENGINE

1. Position the Tractor on a level surface outdoors or in a well-ventilated area.
2. Place the transmission in PARK.
3. Lock the parking brake.

TIP
The starter interlock will prevent the engine from starting if the brake is not engaged.

4. Sit on the Tractor and move the engine stop switch to RUN.

TIP
Do not press the throttle while starting the engine.

5. Turn the ignition key past the ON position to engage the starter. Activate the starter for a maximum of five seconds, releasing the key when the engine starts.
6. If the engine does not start, return the key to the OFF position and wait five seconds before attempting to start again. Activate the starter for another five seconds if necessary. Repeat this procedure until the engine starts.

NOTICE
Operating the Tractor immediately after starting could cause engine damage. Allow the engine to warm up for several minutes before operating the Tractor .

COLD WEATHER OPERATION

If the Tractor is used year-round, check the oil level frequently. A rising oil level could indicate the accumulation of contaminants such as water or excess fuel in the bottom of the crankcase. Water in the bottom of the crankcase can lead to engine damage and must be drained. Water accumulation increases as outside temperature decreases.

See your dealer for engine heater kits, which provide quicker warm-ups and easier starting in colder weather.

STOPPING THE ENGINE

1. Release the throttle pedal completely and brake to a complete stop.
2. Place the transmission in PARK.
3. Turn the key to the OFF position.
4. Slowly release the brake pedal and make sure the transmission is in PARK before exiting the Tractor .

 **WARNING**

A rolling Tractor can cause serious injury. Always place the transmission in PARK before stopping the engine.

WHEN TO USE LOW RANGE AND HIGH RANGE

CONDITION	RANGE TO USE
Operating at speeds less than 11 km/h	Low
Towing heavy loads	Low
Operating in rough or rugged terrain	Low
Operating at speeds greater than 11 km/h	High

HAULING CARGO

WARNING

Overloading the Tractor or carrying or towing cargo improperly can alter Tractor handling and may cause loss of control or brake instability.

Always follow these precautions when hauling cargo.

- Read and understand the load distribution warnings listed on the Tractor warning labels.
- Never exceed the stated load capacity for this Tractor . When determining the weight you are adding , include the weight of the operator, passenger, accessories, loads in the rack or box and the load on the trailer tongue. The combined weight of these items must not exceed the maximum weight capacity.
- **REDUCE SPEED AND ALLOW GREATER DISTANCES FOR BRAKING WHEN HAULING CARGO OR TOWING.** Use extreme caution when applying brakes. Avoid situations that require backing downhill.
- **WEIGHT DISTRIBUTION** on models with front and rear racks should be 1/3 on the front rack and 2/3 on the rear rack. Carrying loads on only one rack increases the possibility of Tractor overturn.
- **CARRY LOADS AS LOW ON THE RACKS AS POSSIBLE.** Carrying loads high on the racks raises the center of gravity of the Tractor and creates a less stable operating condition.
- **SECURE ALL LOADS BEFORE OPERATING.** Unsecured loads can create unstable operating conditions, which could result in loss of control of the Tractor .
- **OPERATE ONLY WITH STABLE AND SAFELY ARRANGED LOADS.** When handling off-centered loads that cannot be centered, securely fasten the load and operate with extra caution. Always attach the tow load to the hitch point designated for your Tractor .
- **HEAVY LOADS CAN CAUSE BRAKING AND CONTROL PROBLEMS.** Use extreme caution when applying brakes with a loaded Tractor . Avoid terrain or situations that may require backing downhill.
- **USE EXTREME CAUTION** when operating with loads that extend over the rack sides. Stability and maneuverability may be adversely affected, causing the Tractor to overturn.
- Towing is approved **OFF-ROAD ONLY** unless your Tractor is approved for on-road operation, with an approved trailer.
- **TOWING SPEED** should never exceed 16 km/h. Never exceed 8 km/h when towing loads in rough terrain, while cornering, or while ascending or descending hills.

1. Always read and understand the load distribution warning labels on the Tractor . Never exceed the weight capacities specified for the Tractor .
2. Always load the cargo box with the load as far forward as possible.

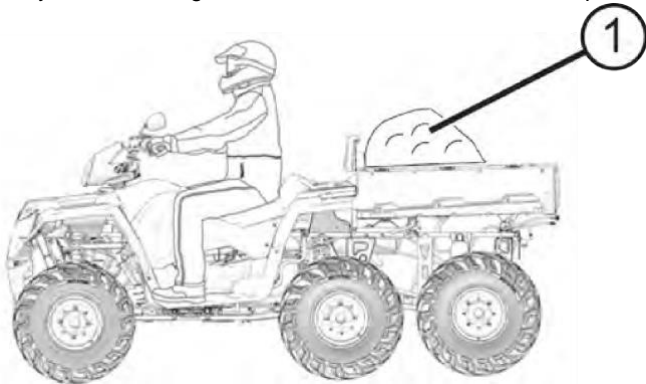

3. Always operate the Tractor with extreme caution whenever hauling or towing loads. Balance, handling and control may be affected.
 4. NEVER exceed 16 km/h when rear cargo loads.
 5. Make sure the cargo box dump latch is securely latched before loading and operating. Unintentional dumping will result if weight is placed in the rear of the box and the latch is not secured.
 6. Always attach a towed load to the hitch point.
-

TOWING LOADS

WARNING

Towing improperly can alter Tractor handling and may cause loss of control or brake instability.

Always follow these precautions when towing:

1. Always shift to low gear for towing.
2. When towing a disabled Tractor, place the disabled Tractor's transmission in neutral. Do not operate the Tractor faster than 16 km/h (10 MPH) when towing.
3. Towing a trailer increases braking distance. Do not operate the Tractor faster than 16 km/h (10 MPH) when towing. Towing a trailer increases braking distance.
4. Do not tow more than the recommended weight for the Tractor. See the towing capacity chart below or the Specifications chapter.
5. Attach a trailer to the approved trailer hitch only.
6. Do not attach a trailer to any other location or you may lose control of the Tractor.
7. Never tow a trailer on a grade steeper than 15°.
8. Always be mindful of the trailer's reaction to Tractor movements when driving off-road.

CAPACITIES	REAR HITCH
Maximum mass towable inertia braked	700 kg
Maximum Vertical Load	50 kg

NOTICE

Using an improper hitch or exceeding the maximum tongue weight capacity can result in serious damage to the Tractor and will void your warranty.

Never install automotive accessories on your POLARIS Tractor. Always install POLARIS-approved (or equivalent) accessories designed for Tractor use.

DUMPING CARGO

WARNING

If cargo weight is placed toward the rear of the cargo box, the load may dump unexpectedly and cause serious injury. When loading cargo, always position the weight as far forward and as low as possible.

1. Select a level site to dump the cargo box. Do not attempt to dump or unload the Tractor while parked on an incline.
2. Place the transmission in PARK.
3. Lock the parking brake.
4. Dismount the Tractor .
5. Check cargo distribution. If cargo has shifted to the rear of the box, exercise caution.
6. Lower the tailgate.
7. Pull one of the cargo box release levers ① forward.



8. Firmly grasp a cargo box handle and slowly lift the front of the cargo box to dump the cargo.

NOTICE

To prevent a crushing injury to hands and fingers, keep hands and fingers away from the lower front edge of the cargo box while lowering the box.

9. Lower the cargo box and make sure the release latch is secured.
10. Secure the tailgate.

NOTICE

Driving with the cargo box in the raised position can cause serious injury and damage to the Tractor . The cargo box could close unexpectedly and injure the driver. The rear tires will also catch the rear of the bed, damaging the Tractor and creating hazardous driving conditions. Never drive this Tractor with the cargo box in the raised position. Never leave this Tractor parked or unattended with the cargo box in the raised position.

TOWING THE TRACTOR

If towing the Tractor is necessary, shift the transmission into neutral for better mobility and to prevent damage to the belt. Always attach the tow cable to the front tow loop of the disabled Tractor . A rider must be on board to steer the disabled Tractor while towing.

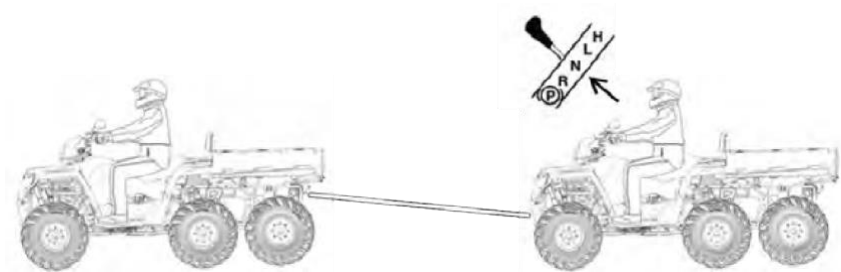

TRAILERING THE TRACTOR

Follow these procedures when transporting the Tractor .



1. Stop the engine.
 2. Place the transmission in PARK.
 3. Secure the fuel cap, oil cap and seat.
 4. Remove the key to prevent loss during transporting.
 5. Always tie the frame of the Tractor to the transporting unit securely with suitable straps or rope. Do not attach tie straps to the front A-arm bolt pockets, racks or handlebars.
-

WINCH GUIDE

WINCH SAFETY IF EQUIPPED

These safety warnings and instructions apply if your Tractor came equipped with a winch or if you choose to add an accessory winch to your Tractor .

 **WARNING**

Improper winch use can result in SEVERE INJURY or DEATH. Always follow all winch instructions and warnings in this manual.

Your winch may have a cable made of either wire rope or specially designed synthetic rope. The term "winch cable" will be used for either unless noted otherwise.

WINCH SAFETY PRECAUTIONS

1. Read all sections of this manual.
 2. Never use alcohol or drugs before or while operating the winch.
 3. Never allow children under 16 years of age to operate the winch.
 4. Always wear eye protection and heavy gloves when operating the winch.
 5. Always keep body, hair, clothing and jewelry clear of the winch cable, fairlead and hook when operating winch.
 6. Never attempt to "jerk" a load attached to the winch with a moving Tractor . See the *Shock Loading* section on page 99.
 7. Always keep the area around the Tractor , winch, winch cable, and load clear of people (especially children) and distractions while operating the winch.
 8. Always turn the Tractor ignition power OFF when it and the winch are not being used.
 9. Always be sure that at least five (5) full turns of winch cable are wrapped around the winch drum at all times. The friction provided by this wrapped cable allows the drum to pull on the winch cable and move the load.
 10. Always apply your Tractor 's park brake and/or park mechanism to hold the Tractor in place during winching. Use wheel chocks if needed.
 11. Always align the Tractor and winch with the load directly in front of the Tractor as much as possible. Avoid winching with the winch cable at an angle to the winching Tractor 's centerline whenever possible.
-

12. If winching at an angle is unavoidable, follow these precautions:
 - a. Look at the winch drum occasionally. Never let the winch cable “stack” or accumulate at one end of the winch drum. Too much winch cable at one end of the winch drum can damage the winch and the winch cable.
 - b. If stacking occurs, stop winching. Follow step 15 of Winch Operation to feed and rewind the cable evenly before continuing the winch operation.
13. Never winch up or down at sharp angles. This can destabilize the winching Tractor and possibly cause it to move without warning.
14. Never attempt to winch loads that weigh more than the winch’s rated capacity.
15. The winch motor may become hot during winch use. If you winch for more than 45 seconds, or if the winch stalls during operation, stop winching and permit the winch to cool down for 10 minutes before using it again.
16. Never touch, push, pull or straddle the winch cable while winching a load.
17. Never let the winch cable run through your hands, even if wearing heavy gloves.
18. Never release the clutch on the winch when the winch cable is under load.
19. Never use the winch for lifting or transporting people.
20. Never use the winch to hoist or suspend a vertical load.
21. Always inspect your winch and winch cable before each use.
22. Never winch the hook fully into the winch. This can cause damage to winch components.
23. Unplug the remote control from the Tractor when the winch is not in use to prevent inadvertent activation and use by unauthorized persons.
24. Never grease or oil the winch cable. This will cause the winch cable to collect debris that will shorten the life of the cable.



WINCH OPERATION

Read the Winch Safety Precautions in the preceding pages before using your winch.

TIP

Consider practicing the operation and use of your winch before you actually need to use it in the field.

⚠ WARNING

Improper winch use can result in SEVERE INJURY or DEATH. Always follow all winch instructions and warnings in this manual.

Each winching situation is unique.

- Take your time to think through the winching you are about to do.
 - Proceed slowly and deliberately.
 - Never hurry or rush during winching.
 - Always pay attention to your surroundings.
 - You may need to change your winching strategy if it is not working.
 - Always remember that your winch is very powerful.
 - There are simply some situations that you and your winch will not be able to deal with. Do not be afraid to ask others to help when this happens.
1. Always inspect the Tractor , winch, winch cable and winch controls for any signs of damage or parts in need of repair or replacement before each use. *Pay particular attention to the first 3 feet (1 meter) of winch cable if the winch is being used (or has been used) for lifting an accessory plow assembly.* Promptly replace any worn or damaged cable.
 2. Never operate a winch or a Tractor in need of repair or service.
 3. Always apply your Tractor 's park brake and/ or park mechanism to hold the Tractor in place during winching. Use wheel chocks if needed.
 4. Always use the hook strap when handling the hook.



WARNING

Never put your fingers into the hook. This could lead to SEVERE INJURY.

- Attach the hook itself onto the load or use a tow strap or chain to secure the load to the winch cable.



TIP

A “tow strap” is NOT intended to stretch. A “recovery strap” is designed to stretch.

WARNING

Never use a recovery strap when winching due to the excessive energy that can be released if the winch cable breaks. This can result in SEVERE INJURY or DEATH. See the *Shock Loading* section

- Never hook the winch cable back onto itself. This will damage the winch cable and may result in winch cable failure.

WARNING

Replace the winch cable at the first sign of damage to prevent SEVERE INJURY or DEATH in the event of failure. For your safety, always replace winch parts (including the cable) with genuine replacement parts available at your authorized dealer, or other qualified dealer.

- If possible, keep the winch cable aligned with the centerline of the winching Tractor . This will help the spooling of the winch cable and reduce the load on the fairlead.
- If freeing a stuck Tractor by attaching to a tree, use an item such as a tow strap to avoid damaging the tree during winch operation. Sharp cables and chains can damage and even kill trees. Please remember to Tread LightlySM
- Before operating the winch, be sure that the safety latch on the winch cable hook is fully seated when the load is attached.
- Never operate your winch with a damaged hook or latch. Always replace damaged parts before using the winch.

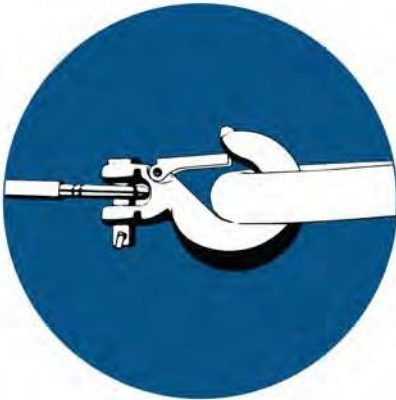

5. Never remove the hook strap from the hook.
 6. Release the winch clutch and pull out the winch cable.
 7. Pulling out as much cable as possible maximizes the winch's pulling capacity. Always be sure that at least five (5) full turns of winch cable are wrapped around the winch drum at all times. The friction provided by this wrapped cable allows the drum to pull on the winch cable and move the load.
 8. Read and adhere to the following information for winch damping to ensure safe winch use.
 - a. In order to absorb energy that could be released by a winch cable failure, always place a "damper" on the winch cable. A damper can be heavy jacket, tarp, or other soft, dense object. A damper can absorb much of the energy released if a winch cable breaks when winching. Even a tree limb can help as a damper if no other items are available to you.
 - b. Lay the damper on top of the mid-point of the winch cable length that is spooled out.
-

- c. On a long pull, it may be necessary to stop winching so that the damper can be repositioned to the new mid-point of the winch cable. Always release the tension on the winch cable before repositioning the damper.
 - d. Avoid being directly in line with the winch cable whenever possible. Also, never permit others to stand near or in line with the winch cable during winch operation.
9. Never hook the winch cable back onto itself. This will damage the winch cable and may result in winch cable failure.
10. Never use straps, chains or other rigging items that are damaged or worn.
11. The ONLY time a winch-equipped Tractor should be moving when using the winch is when that Tractor itself is stuck. The winch equipped Tractor should NEVER be in motion to “shock” load the winch cable in an attempt to move a second stuck Tractor . See the Shock Loading section on page 99. For your safety, always follow these guidelines when winching a Tractor free:
- a. Release the winch clutch and spool out the necessary length of winch cable.
 - b. Align the winch cable as close as possible to the winching Tractor 's centerline.
 - c. Attach the winch cable hook to the anchor point or the stuck Tractor 's frame following instructions in this manual.
 - d. Re-engage the clutch on the winch.
 - e. Slowly winch in the slack in the winch cable.
 - f. Select the proper Tractor gear to propel the stuck Tractor in the direction of winching.
 - g. Shift to the lowest gear available on the stuck Tractor .
 - h. Slowly and carefully apply Tractor throttle and winch together to free the Tractor .
 - i. Stop winching as soon as the stuck Tractor is able to propel itself without the help of the winch.
 - j. Detach the winch cable hook.
 - k. Rewind the winch cable evenly back onto the winch drum following the instructions in this manual.
12. Never attempt to winch another stuck Tractor by attaching the winch cable to a suspension component, brush guard, bumper or cargo rack. Tractor damage may result. Instead, attach the winch to a strong portion of the Tractor frame or hitch.
-

13. Extensive winching will run down the battery on the winching Tractor . Let the winching Tractor 's engine run while operating the winch to prevent the battery from running low if winching for long periods.
 14. The winch motor may become hot during winch use. If you winch for more than 45 seconds, or if the winch stalls during operation, stop winching and permit the winch to cool down for 10 minutes before using it again.
 15. After winching is complete, especially if winching at an angle, it may be necessary to re-distribute the winch cable across the winch drum. You will need an assistant to perform this task.
 - a. Release the clutch on the winch.
 - b. Feed out the winch cable that is unevenly bunched up in one area.
 - c. Re-engage the winch clutch.
 - d. Have an assistant pull the winch cable tightly with about (45 kg) of tension using the hook strap.
 - e. Slowly winch the cable in while your assistant moves the end of the winch cable back and forth horizontally to evenly distribute the winch cable on the drum.
 - f. Doing this reduces the chances of the winch cable "wedging" itself between lower layers of winch cable.
-

WINCH CABLE CARE

WARNING

Use of worn or damaged cable could lead to sudden failure and SEVERE INJURY.

For your safety, always replace POLARIS winch parts (including the cable) with genuine POLARIS replacement parts available at your authorized POLARIS dealer, or other qualified person.

1. Always inspect your winch before each use. Inspect for worn or loose parts including mounting hardware. Never use the winch if any part needs repair or replacement.
2. Always inspect your winch cable before each use. Inspect for worn or kinked winch cable.

A kinked winch cable made of wire rope is shown at right. Even after being “straightened out,” this cable has already been permanently and severely damaged. Promptly discontinue use of a winch cable in this condition.

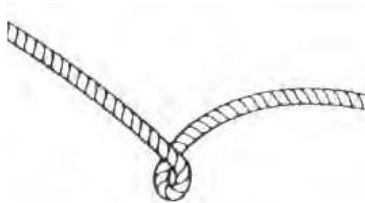

A kinked winch cable made of wire rope that has been “straightened out” is shown at right. Even though it may look usable, the cable has been permanently and severely damaged. It can no longer transmit the load that it could prior to kinking. Promptly discontinue use of a winch cable in this condition.

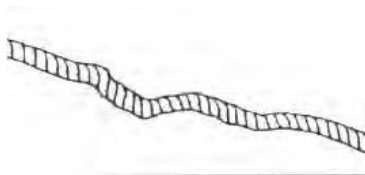

A winch cable made of synthetic rope should be inspected for signs of fraying. Replace the cable if fraying is observed (shown below). Promptly discontinue use of a winch cable in this condition. Also replace the winch cable if there are fused or melted fibers. Such an area of the synthetic rope will be stiff and appear smooth or glazed. Promptly discontinue use of a winch cable in this condition.

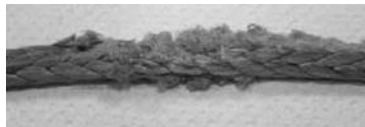

SHOCK LOADING

 **WARNING**

Your winch cable is very strong but it is NOT designed for dynamic, or “shock” loading. Shock loading may tension a winch cable beyond its strength and cause the cable to break. The end of a broken winch cable under such high loading can cause SEVERE INJURY or DEATH to you and other bystanders.

Winch cables are designed to NOT absorb energy. This is true of both wire-ropes and synthetic-rope winch cables.

1. Never attempt to “jerk” a load with the winch. For example, never take up slack in the winch cable by moving the winching Tractor in an attempt to move an object. This is a dangerous practice. It generates high winch cable loads that may exceed the strength of the cable. Even a slowly moving Tractor can create large shock loads in a winch cable.

 **WARNING**

SEVERE INJURY or DEATH can result from a broken winch cable.

2. Never quickly turn the winch ON and OFF repeatedly (“jogging”). This puts extra load on the winch, winch cable, and generates excessive heat from the motor. This is a form of shock loading.
3. Never tow a Tractor or other object with your winch. Towing an object with a winch produces shock loading of the cable even when towing at slow speeds. Towing from a winch also positions the towing force high on the Tractor. This can cause instability of the Tractor and possibly lead to an accident.
4. Never use recovery straps with your winch. Recovery straps are designed to stretch and can store energy. This stored energy in the recovery strap is released if a winch cable fails making the event even more hazardous. Similarly, never use elastic “bungee” cords for winching.
5. Never use the winch to tie down a Tractor to a trailer or other transportation Tractor. This type of use also causes shock loading that can cause damage to the winch, winch cable, or Tractor s used.

Your winch cable is designed and tested to withstand the loads produced by the winch motor when operated from a stationary Tractor. Always remember that the winch and winch cable are NOT designed for shock loading.

WINCH MAINTENANCE AND SERVICE SAFETY

 **WARNING**

Improper or lack of winch maintenance and service could lead to SEVERE INJURY or DEATH. Always follow all winch instructions and warnings in this manual.

1. Always inspect your winch before each use. Inspect for worn or kinked winch cable. Also inspect for worn or loose parts including mounting hardware.
2. Permit your winch motor to cool down prior to servicing your winch.
3. Never work on your winch without first disconnecting the battery connections to prevent accidental activation of the winch.
4. For your safety, always replace winch parts (including the cable) with genuine replacement parts available at your authorized dealer, or other qualified person.
5. Some winch models use wire rope as the winch cable. Other winches use a specially designed synthetic rope as the winch cable.
6. Never replace a synthetic-rope winch cable with a consumer-grade polymer rope such as can be purchased in a hardware store. Although they may look similar, they are NOT alike. A polymer rope not designed for winch use will stretch and store excessive energy when winching.

 **WARNING**

Failure of a stretched rope under winching conditions will release all of the stored energy. This will increase the chances of SEVERE INJURY or DEATH.

EMISSION CONTROL SYSTEMS

NOISE EMISSION CONTROL SYSTEM

Do not modify the engine, intake or exhaust components, as doing so may affect compliance with governmental noise level requirements.

SPARK ARRESTER

Your Tractor has a spark arrester that was designed for on-road and off-road operation. It is required that this spark arrester remain installed and functional when the Tractor is operated.

EXHAUST EMISSION CONTROL SYSTEM

Exhaust emissions are controlled by engine design. An electronic fuel injection (EFI) system controls fuel delivery. The engine and EFI components are set at the factory for optimal performance and are not adjustable.

ELECTROMAGNETIC INTERFERENCE

This Tractor complies with the EMC requirements of European directive 2014/30/EU.

Non-ionizing Radiation: This Tractor emits some electromagnetic energy. People with active or non-active implantable medical devices (such as heart monitoring or controlling devices) should review the limitations of their device and the applicable electromagnetic standards and directives that apply to this Tractor .

CARBON DIOXIDE (CO₂) EMISSION

The CO₂ measurement results from testing the engine over a fixed test cycle under laboratory conditions pass the European laws concerning emission .

The engine guarantee the performance if the program of maintenance is respected.

EUROPEAN VIBRATION AND NOISE

The driver-perceived noise and hand/arm and whole body vibration levels of this machinery is measured per EN 15997.

		Sportsman 570 6X6
Noise	Moving	81 db (a)
	Stationary	93 db (a)
Vibration	Weighted Hand-Arm Vibration Level	<2.5 m/s ²
	Weighted Seat Vibration Level	<0.5 m/s ²

MAINTENANCE

PERIODIC MAINTENANCE

Careful periodic maintenance will help keep your Tractor in the safest, most reliable condition. Inspection, adjustment and lubrication of important components are explained in the periodic maintenance chart.

Inspect, clean, lubricate, adjust and replace parts as necessary. When inspection reveals the need for replacement parts, use genuine parts available from your authorized dealer.

Record maintenance and service in the Maintenance Log section at the end of the manual.

Service and adjustments are important for proper Tractor operation. If you're not familiar with safe service and adjustment procedures, have a qualified dealer perform these operations.

Maintenance intervals in the following chart are based upon average riding conditions and an average Tractor speed of approximately 16 kilometers per hour .

Tractor s subjected to severe use must be inspected and serviced more frequently.

SEVERE USE DEFINITION

- Frequent immersion in mud, water or sand
- Frequent or prolonged operation in dusty environments
- Short trip cold weather operation
- Racing or race-style high RPM use
- Prolonged low speed, heavy load operation
- Extended idle

Pay special attention to the oil level. A rise in oil level during cold weather can indicate contaminants collecting in the oil sump or crankcase. Change oil immediately if the oil level begins to rise. Monitor the oil level, and if it continues to rise, discontinue use and determine the cause. Your dealer can assist.

ELEVATING THE TRACTOR FOR SERVICE

Some service procedures require elevation of the Tractor. Always position the Tractor on a firm, level surface before elevating. Do not position a jack or jack stand under any components other than the frame. Use an appropriate lift or floor jack. This Tractor is not equipped with dedicated jacking points. Place the floor jack at the front (or rear) of the Tractor, directly under the center of the unit. Make sure the floor jack makes contact only with the *frame* of the Tractor while lifting ①. Do not allow the Tractor to remain elevated on a floor jack. After elevating, place jack stands under the *frame* on each side of the floor jack, then lower the floor jack.

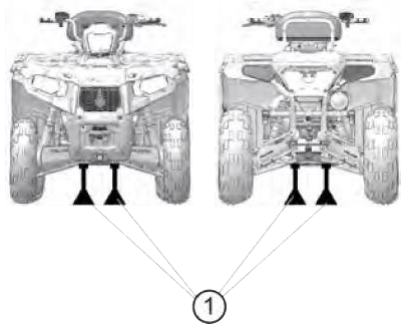

MAINTENANCE CHART

SYMBOL	DESCRIPTION
XU	Perform these procedures more often for Tractor s subjected to severe use.
D	Have an authorized Polaris dealer or other qualified person perform these services.

WARNING

Improperly performing the procedures marked with a **D** could result in component failure and lead to serious injury or death. Have an authorized dealer or other qualified person perform these services.

Perform all services at whichever maintenance interval is reached first. Record maintenance and service in the Maintenance Log.

ITEM	MAINTENANCE INTERVAL (WHICHEVER COMES FIRST)			REMARKS
	HOURS	CALENDAR	MILES (KM)	
Steering		Pre-Ride		Inspect and make adjustments as needed.
Front Suspension				
Rear Suspension				
Tires				
Brake Fluid Level				
Brake Lever Travel				
Brake System				
Wheels / Fasteners				
CV Boot				
Frame Fasteners				
Engine Oil Level				
Winch (if equipped)				
XU Air Filter (Pre-Filter)	-	Daily	-	Inspect; clean often; replace as needed
Coolant	-	Daily	-	Check level daily, change coolant every two years
Head Lights / Tail Lights	-	Daily	-	Check operation; apply dielectric grease if replacing
Power Steering unit (If equipped)	-	Daily		Inspect daily, clean often

MAINTENANCE

ITEM		MAINTENANCE INTERVAL (WHICHEVER COMES FIRST)			REMARKS
		HOURS	CALENDAR	MILES (KM)	
XU	Brake Pad Wear	10 H	Monthly	100 (160)	Inspect periodically
	Battery	20 H	Monthly	200 (320)	Check terminals; clean; test
	Fuel and EVAP System (if equipped)	20 H	Monthly	-	Inspect; cycle key to pressurize fuel pump; check lines and fittings for leaks and abrasion. Replace as needed
XU	Engine Oil Change	25 H	1 M	-	Break-in oil and filter change
	Engine Breather	25 H	1 M	250 (400)	Inspect; replace as needed
XU	Demand Drive Fluid	25 H	1 M	250 (400)	Break-in fluid change
XU	Rear Gearcase Oil	25 H	1 M	250 (400)	Break-in fluid level check
XU	Transmission Fluid	25 H	1 M	250 (400)	Break-in fluid level check
XU	General Lubrication	50 H	3 M	500 (800)	Lubricate all fittings, pivots, cables, etc.
	Shift Linkage	50 H	3 M	500 (800)	Inspect
D	Steering	50 H	6 M	500 (800)	Lubricate
XU	Front/Rear Suspension	50 H	6 M	500 (800)	Lubricate
XU	Throttle Release Switch (if equipped)	50 H	6 M	500 (800)	Inspect; adjust; lubricate; replace if necessary
	Throttle Body Intake Duct	50 H	6 M	500 (800)	Inspect ducts for proper sealing / air leaks
	Drive Belt	50 H	6 M	500 (800)	Inspect; replace as needed
XU	Air Filter (main element)	50 H	6 M	500 (800)	Inspect; replace as needed
	Cooling System	50 H	6 M	1000 (1600)	Inspect coolant strength seasonally; pressure test system yearly
XU	Radiator	50 H	6 M	1000 (1600)	Inspect; clean external surfaces
XU	Cooling Hoses	50 H	6 M	1000 (1600)	Inspect for leaks
XU	Shocks	50 H	-	500 (800)	Inspect for leaks, loose joints, and wear
XU	Oil lines and fasteners	100 H	6 M	1000 (1600)	Inspect for leaks and loose fittings

MAINTENANCE

ITEM		MAINTENANCE INTERVAL (WHICHEVER COMES FIRST)			REMARKS
		HOURS	CALENDAR	MILES (KM)	
XU	Engine oil change	100 H	6 M	1000 (1600)	Change the oil and filter
D	Fuel and EVAP System (if equipped)	100 H	12 M	1000 (1600)	Inspect; cycle key to pressurize fuel pump; check lines and fittings for leaks and abrasion. Replace as needed
XU	Engine Mounts	100 H	12 M	1000 (1600)	Inspect
	Exhaust Pipe / Silencer / Joints	100 H	12 M	1000 (1600)	Inspect; replace worn parts
XU	Spark Plug	100 H	12 M	1000 (1600)	Inspect; replace as needed
XU	Wiring	100 H	12 M	1000 (1600)	Inspect for wear, routing, security; apply dielectric grease to connectors subjected to water, mud, etc.
D	Clutches (Drive/Driven)	100 H	12 M	1000 (1600)	Inspect; clean; replace worn parts
D	Wheel Bearings	100 H	12 M	1000 (1600)	Inspect; replace as needed
D	Brake Fluid	200 H	24 M	2000 (3200)	Change every two years
XU	Demand drive fluid (normal use)	200 H	24 M	2000 (3200)	Change fluid
XU	Rear gearcase oil	200 H	24 M	2000 (3200)	Change fluid
XU	Transmission oil	200 H	24 M	2000 (3200)	Change fluid
XU	Valve Clearance	200 H	-	2000 (3200)	Inspect; adjust as needed
XU D	Shocks	250 H	-	2500 (4000)	Replace shocks
	Spark Arrestor	300 H	36 M	3000 (4800)	Clean out; or remove clean out plug. If driving in mud, service/clean spark arrestor daily.
XU	Coolant	-	60 M	-	Replace coolant (50/50 Extended Life Coolant)
D	Toe Adjustment		-		Inspect periodically; adjust as needed
	Headlight Aim		-		Adjust as needed

LUBRICATION GUIDE

Check and lubricate all components at the intervals outlined in the Periodic Maintenance Chart. Items not listed in the chart should be lubricated at the General Lubrication interval.

The a-arms and upper control arms are lubricated at the factory, and no additional lubrication will be needed. However, if these components are subjected to severe use, grease zerks have been provided for additional lubrication at the user's discretion.

ITEM	RECOMMENDED LUBRICANT	CAPACITY AT FLUID CHANGE	INSPECTION PROCEDURE
Engine Oil	PS-4 5W-50 4-Cycle Oil	1.9 l (2 qt.)	Maintain level in safe range on dipstick. See page 109.
Brake Fluid	DOT 4 Brake Fluid	—	Maintain level between fill lines. See page 118.
Transmission Oil	AGL Gearcase Lubricant & Transmission Fluid	1000 ml (34 oz.)	Maintain level at bottom of fill hole threads. See page 112.
Demand Drive Fluid (Front Gearcase)	Demand Drive Fluid	275-300 ml (9-10 oz.)	Maintain level at bottom of fill hole threads. See page 113.
Rear Gearcase Oil	ATV Angle Drive Fluid (or GL5 80-90 weight gear lube)	150 ml (5 oz.)	See page 115
Front Prop Shaft Yoke	U-Joint Grease	—	Grease fittings (3 pumps maximum) every 800 km (500 miles), before long periods of storage, or after pressure washing or submerging.

① Front Prop Shaft Yoke

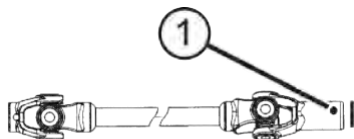

ENGINE OIL

Always check and change the oil at the intervals outlined in the Periodic Maintenance Chart. Always use the recommended engine oil. Always change the oil filter whenever changing oil.

Pay special attention to the oil level. A rise in oil level during cold weather can indicate contaminants collecting in the oil sump or crankcase. Change oil immediately if the oil level begins to rise. Monitor the oil level, and if it continues to rise, discontinue use and determine the cause. Your dealer can assist.

WARNING

Tractor operation with insufficient, deteriorated, or contaminated engine oil will cause accelerated wear and may result in engine seizure, accident and injury. Always perform the maintenance procedures as outlined in the Periodic Maintenance Chart.

OIL RECOMMENDATIONS

Always change the oil filter whenever changing oil.

We recommends the use of PS-4 Full Synthetic 5W-50 4-cycle oil or a similar oil for this engine. Oil may need to be changed more frequently used in stress . Always use 5W-50 4 Cycle oil. Follow the manufacturer's recommendations for ambient temperature operation.

See the Lubrication Guide section for fluid recommendations, capacities and plug torques.

NOTICE

Mixing brands or using a non-recommended oil may cause serious engine damage. Always use the recommended oil. Never substitute or mix oil brands.

OIL SPECIFICATIONS

LUBRICANT	CAPACITY	DRAIN PLUG TORQUE
PS-4 5W-50 4-Cycle Oil	1.9 liter	2 kg

OIL LEVEL

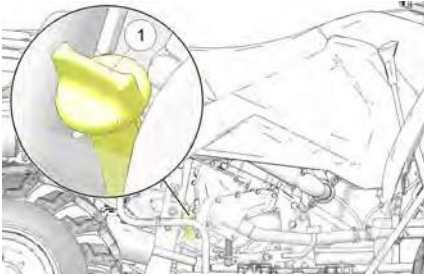

Access the oil dipstick ① under the oil check flap and fill tube from the right side of the Tractor. A rising oil level between checks in cool weather driving can indicate contaminants such as gas or moisture collecting in the crankcase. If the oil level is over the full/safe mark, change the oil immediately.

1. Position the Tractor on a level surface. Place the transmission in PARK.
2. Remove the dipstick. Wipe it dry with a clean cloth.
3. Reinstall and tighten the dipstick.
4. Remove the dipstick and check the oil level.
5. Add the recommended fluid as needed. Maintain the oil level within the safe range ②. Do not overfill.
6. Reinstall and tighten the dipstick.

OIL AND FILTER CHANGE

Always change the oil and filter at the intervals outlined in the Periodic Maintenance Chart. Always change the oil filter ① whenever changing oil.

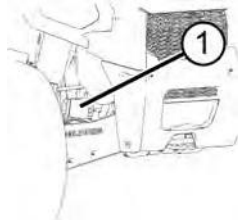

1. Position the Tractor on a level surface.
2. Start the engine. Allow it to warm up at idle for two to three minutes.
3. Stop the engine.

- Clean the area around the drain plug ②.

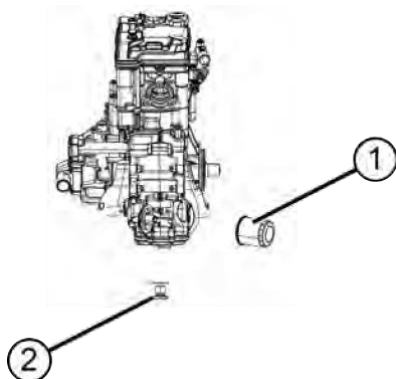

- Place a drain pan under the crank case.
- Remove the drain plug. Allow the oil to drain completely.

⚠ WARNING

Hot oil can cause burns to skin. Do not allow hot oil to contact skin.

- Install a new sealing washer on the drain plug. The sealing surfaces on drain plug and crankcase should be clean and free of burrs, nicks or scratches.
 - Reinstall the drain plug. Torque to 2 kg
 - Using an oil filter wrench (available from your dealer), turn the filter counter-clockwise to remove it.
 - Using a clean, dry cloth, clean the filter sealing surface on the crankcase.
 - Lubricate the o-ring on the new filter with a film of fresh engine oil. Check to make sure the o-ring is in good condition.
 - Install a new filter and rotate it clockwise by hand until the filter gasket contacts the sealing surface, then turn it an additional 3/4 turn.
 - Remove the dipstick.
 - Add 1.9 liters of recommended oil.
 - Place the transmission in PARK.
 - Lock the parking brake.
 - Start the engine. Allow it to idle for one to two minutes.
 - Stop the engine.
-

19. Check for leaks.
20. Check the oil level. Add oil as needed to bring the level to the upper mark on the dipstick.
21. Dispose of used filter and oil properly.

TRANSMISSION OIL

Always check and change the transmission oil at the intervals outlined in the Periodic Maintenance Chart. Maintain the oil level at the bottom of the fill plug ① hole threads. See the products section for the part numbers.

The fill plug is located on the left side of the ATV, under the rear fender, behind the wheel. The drain plug ② is located on the right side of the gearcase, on the right side of the ATV, behind the wheel well.

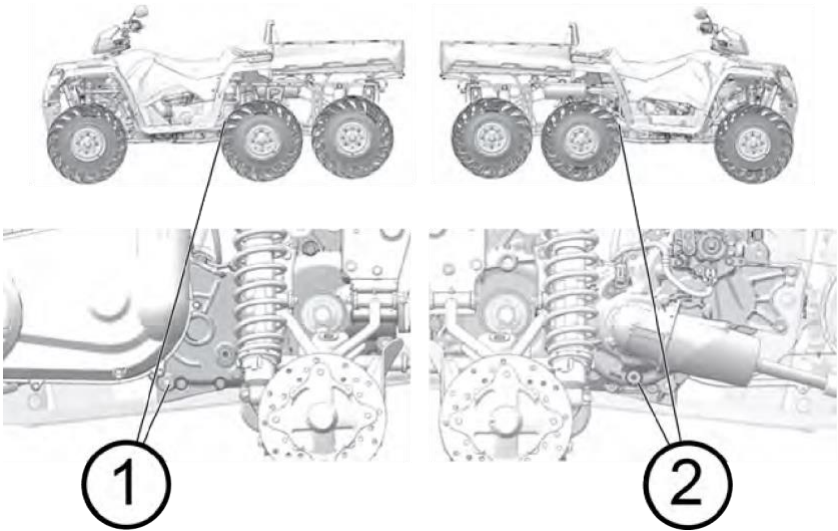

TRANSMISSION OIL RECOMMENDATIONS

LUBRICANT	CAPACITY	FILL PLUG TORQUE	DRAIN PLUG TORQUE
AGL Gearcase Lubricant & Transmission Fluid	1 liter	2,5 kg	2,5 kg

TRANSMISSION OIL CHECK

1. Position the Tractor on a level surface.
2. Remove the fill plug ①. Check the oil level.
3. Add the recommended fluid as needed to bring the level to the bottom of the fill hole threads ②.
4. Reinstall the fill plug. Torque to specification.



TRANSMISSION OIL CHANGE

1. Remove the fill plug.
2. Place a drain pan under the gearcase. Remove the drain plug. Allow the oil to drain completely.
3. Clean and reinstall the drain plug. Torque to specification.
4. Add the proper amount of the recommended oil.
5. Reinstall the fill plug. Torque to specification.
6. Check for leaks.
7. Dispose of used oil properly.

FRONT GEARCASE (DEMAND DRIVE) FLUID

Always check and change the demand drive fluid at the intervals outlined in the Periodic Maintenance Chart. Maintain the fluid level at the bottom of the fill hole threads. See the Products section for part numbers.

Change the front gearcase fluid every 25 hours if the 4WDC unit is exposed to extreme use. Extreme use includes any of the following:

- operation in 6WDC mode for prolonged periods
- constant 6WDC operation on hilly or mountainous terrain
- 6WDC is the primary mode of all-wheel-drive operation

TIP

If the front gearcase makes excessive noise during 6WDC operation, change the demand drive fluid. If the noise continues, please see your dealer for service.

FLUID RECOMMENDATIONS

GEARCASE	LUBRICANT	CAPACITY	FILL PLUG TORQUE	DRAIN PLUG TORQUE
Front Gearcase	Demand Drive Fluid	0,3 liter	1 kg	1,5 kg

Use the recommended fluid. Use of other fluids may result in improper operation of components. Maintain the fluid level at the bottom of the fill hole threads.

The fill plug is located on the right side of the demand drive unit. The drain plug is located on the bottom right side of the unit.

- ① Fill Plug
- ② Drain Plug
- ③ Fill Level

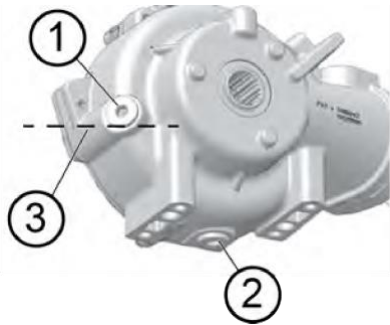

FLUID CHECK

1. Position the Tractor on a level surface. Remove the fill plug. Check the fluid level.
2. Add the recommended fluid as needed to bring the level to the bottom of the fill hole threads.
3. Reinstall the fill plug. Torque to specification.

FLUID CHANGE

1. Position the Tractor on a level surface. Remove the fill plug.
2. Place a drain pan under the demand drive unit. Remove the drain plug. Allow the fluid to drain completely.
3. Clean and reinstall the drain plug. Torque to specification.
4. Add the proper amount of the recommended fluid.
5. Reinstall the fill plug. Torque to specification.
6. Check for leaks. Dispose of used fluid properly.

REAR GEARCASE OIL

- Always check and change the rear gearcase oil at the intervals outlined in the Periodic Maintenance Chart section.
- Maintain the fluid level at the bottom of the fill hole threads. Do not overfill.
- The fill plug ① is located on the rear of the gearcase. The drain plug ② is located on the bottom of the gearcase.

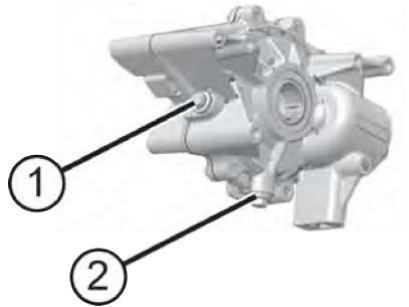

REAR GEARCASE FLUID RECOMMENDATIONS

GEARCASE	LUBRICANT	CAPACITY	FILL PLUG TORQUE	DRAIN PLUG TORQUE
Rear Gearcase	POLARIS ATV Angle Drive Fluid (or GL5 80-90 weight gear lube)	0,15 liter	1,9 kg	1,9 kg

OIL CHECK

1. Position the Tractor on a level surface.
2. Remove the fill plug. Check the oil level.
3. Add the recommended oil as needed to bring the level to the bottom of the fill hole threads. *Do not overfill.*
4. Reinstall the fill plug. Torque to specification.

OIL CHANGE

1. Position the Tractor on a level surface.
2. Place a drain pan under the drain hole.
3. Remove the drain plug. Allow the oil to drain completely.
4. Clean and reinstall the drain plug with a new sealing washer. Torque to specification.
5. Remove the fill plug. Add the proper amount of the recommended oil. *Do not overfill.*
6. Reinstall the fill plug. Torque to specification.
7. Check for leaks.
8. Dispose of used oil properly.

COOLING SYSTEM

The engine coolant level is controlled, or maintained, by the recovery system. The recovery system components are the recovery bottle, the radiator filler neck, the radiator pressure cap and the connecting hose.

As coolant operating temperature increases, the expanding (heated) excess coolant is forced out of the engine, past the pressure cap, and into the recovery bottle. As engine coolant temperature decreases the contracting (cooled) coolant is drawn back up from the bottle, past the pressure cap, and into the radiator.

Some coolant level drop on new Tractor s is normal as the system is purging itself of trapped air. Check the coolant level and maintain as recommended by adding coolant to the recovery bottle.

POLARIS recommends the use of POLARIS Antifreeze 50/50 Premix. This antifreeze is already premixed and ready to use. Do not dilute with water. See the Polaris Products section for the part numbers.

RECOVERY BOTTLE COOLANT

The recovery bottle ① is located on the left side of the Tractor .

1. Remove the left side panel. See the Side Panel Removal section.
2. Maintain the coolant level between the minimum and maximum marks on the bottle (when the fluid is cool).
3. Add coolant as needed.

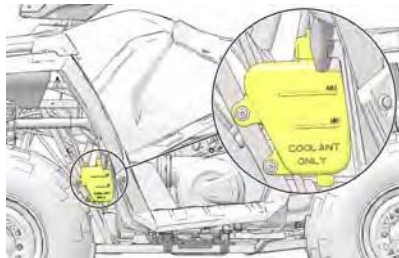

RADIATOR COOLANT

To ensure that the coolant maintains its ability to protect the engine, we recommend that the system be completely drained every five (5) years and fresh Antifreeze 50/50 Premix added.

Any time the cooling system has been drained for maintenance or repair, replace the coolant with fresh Antifreeze 50/50 Premix. If the recovery bottle has run dry, check the level in the radiator. Add coolant as needed.

CAUTION

Escaping steam can cause burns. Never remove the pressure cap while the engine is warm or hot. Always allow the engine to cool before removing the pressure cap.

1. Open the front box cover.
2. Remove the access panel screws. Squeeze the outer edges of the panel inward to remove the panel.
3. Remove the pressure cap ①.

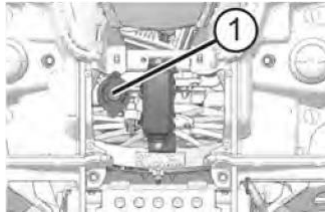

4. Using a funnel, slowly add coolant through the radiator filler neck.
 5. Reinstall the pressure cap. Use of a non-standard pressure cap will not allow the recovery system to function properly. Contact your dealer for the correct replacement part.
 6. Reinstall the access panel and secure the front box cover.
-

BRAKES

BRAKE FLUID

Check brake fluid levels for both brake systems before each ride. Always maintain brake fluid at the recommended level. Do not overfill.

The brakes should feel firm when they're applied. Spongy or weak brakes may indicate a fluid leak or low fluid level. A low fluid level may also mean that brake pads are worn and need to be replaced. Do not operate the Tractor with spongy or weak brakes. See your dealer for service.

 **CAUTION**

Operating the Tractor with a spongy brake can result in loss of braking, which could cause an accident. Never operate the Tractor with spongy-feeling brakes.

If the fluid level is low add DOT 4 brake fluid only. See the Polaris Products section for part numbers.

 **WARNING**

An over-full master cylinder may cause brake drag or brake lock-up, which could result in serious injury or death. Maintain brake fluid at the recommended level. Do not overfill.

Under normal operation, the diaphragm extends into the reservoir as fluid level drops. If the fluid level is low and the diaphragm is not extended, a leak is likely and the diaphragm should be replaced. To ensure proper diaphragm operation, always fill the reservoir as needed whenever the cover is loosened or removed. Do not overfill.

 **WARNING**

Never store or use a partial bottle of brake fluid. Brake fluid is hygroscopic, meaning it rapidly absorbs moisture from the air. The moisture causes the boiling temperature of the brake fluid to drop, which can lead to early brake fade and the possibility of accident or severe injury. After opening a bottle of brake fluid, always discard any unused portion.

HAND BRAKE

The master cylinder ① is located on the left handlebar. Maintain the fluid level 6 mm below the top edge of the master cylinder. Do not overfill.

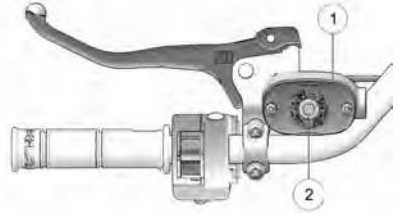

1. Position the Tractor on a level surface. Make sure the handlebars are straight.
2. View the fluid level through the indicator window (eye) ② on the top of the master cylinder.

TIP

The eye will appear dark when the fluid level is full ③. When fluid is low ④, the eye will be clear.

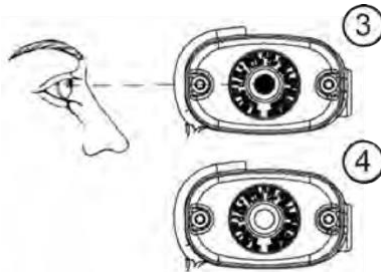

3. If the fluid level is low, remove the cover screws and add fluid to the fill line. *Do not overfill.*
4. Reinstall the cover. Torque screws to 0,8 kg

FOOT BRAKE

Check the brake fluid level frequently for the foot brake system. The foot brake fluid reservoir ① is located under the seat.



1. Position the Tractor on a level surface.
2. Remove the seat.
3. View the fluid level in the reservoir.
4. Remove the cap and add the recommended fluid as needed.
5. Maintain the fluid level between the minimum ③ and maximum ② marks. Do not overfill.

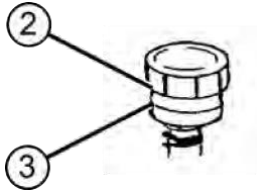

6. Reinstall the reservoir cap.
 7. Reinstall the seat.
-

BRAKE INSPECTION

The front and rear brakes are hydraulic disc brakes, activated by applying the foot brake. The handlebar brake is also hydraulic. Both brake systems are self-adjusting.

Perform the following checks to keep the brake systems in good operating condition. Check more often if brakes are used heavily under normal operation.

1. Always keep brake fluid at an adequate level.
2. Check the brake systems regularly for fluid leaks.
3. Check the brakes for excessive travel or spongy feel.
4. Check the friction pads for wear, damage, and looseness. Replace the pads when the friction material is worn to 0.762 mm.

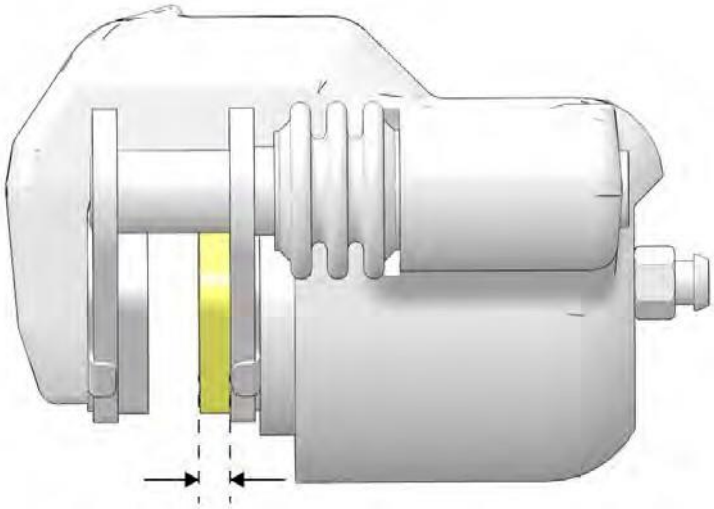

5. Check the security and surface condition of the disc. Clean any grease using a recommended brake cleaner or alcohol. Do not use spray lubricants or other petroleum-based products. If you discover any damage (cracks, excessive corrosion, warping) see your dealer for service before operating.
-

TOE ALIGNMENT

NOTICE

Do not attempt to adjust alignment. All steering adjustments should be performed by an authorized service technician. Your authorized dealer can assist.

Use the following procedure to check the toe alignment of the Tractor . The recommended toe alignment is 3-6 mm toe out.

1. Position the Tractor on a level surface.
2. Place the handlebars in a straight-ahead position.
3. Tie a length of string ③ between two stands as shown in the illustration. Position the stand ④ so that the string is flush with the side of the rear tire.

TIP

If available, you may use a long straight-edge instead of string.

4. Measure the distance from the string to the rim at the front ① and rear ② of the front rim. The rear measurement should be 2-3 mm more than the front measurement on each side of the Tractor to obtain the recommended 3-6 mm toe out alignment.
5. Repeat the measurement procedure on the other side of the Tractor .
6. If you discover improper alignment, service is required. Your authorized dealer can assist.

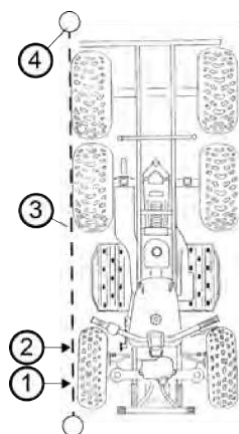

HANDLEBAR ADJUSTMENT

The handlebars can be adjusted for rider preference.

NOTICE

Improper adjustment of the handlebars or incorrect torquing of the adjuster block tightening bolts can cause limited steering or loosening of the handlebars, resulting in loss of control. Follow the adjustment procedures exactly, or see your authorized dealer for service.

1. Remove the upper headlight pod.
2. Loosen the four handlebar bolts.
3. Adjust the handlebar to the desired height.
4. Be sure the handlebars do not contact the gas tank or any other part of the machine when turned fully to the left or right.
5. Torque the front two bolts ① to 14-17 Nm, then torque the rear two bolts. A gap of up to 3 mm will remain at the rear of the clamp blocks.

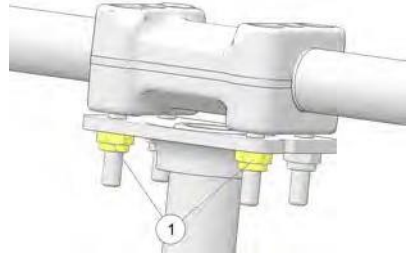

STEERING ASSEMBLY

The steering assembly of the ATV should be checked periodically for loose nuts and bolts. If loose nuts and bolts are found, see your authorized dealer or other qualified service facility before operating the Tractor .

REAR SPRING

The rear shock absorber spring is adjusted by rotating the cam either clockwise or counter-clockwise to increase or decrease spring tension.

- ① Cam
- ② High Tension
- ③ Low Tension

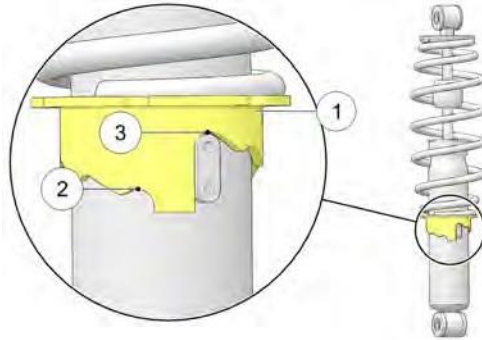

POWER STEERING UNIT

If your model is equipped with power steering, frequently clean the areas around and on the power steering unit to allow proper cooling. Clean these areas thoroughly.

SEAT REMOVAL

1. Grasp one side of the seat near the rear edge.
2. Pull upward abruptly to disengage the under-seat fasteners.
3. Remove the seat.

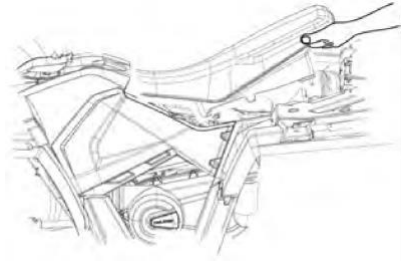

SIDE PANEL REMOVAL

1. Remove the seat.
2. Use a flat screwdriver to remove the plastic rivets securing the side panel.
3. Grasp the rear of the side panel near the rear cab. With a firm motion, pull the side panel outward to disengage the side panel from the grommets.
4. Pull the panel outward and rearward to remove it.

FOOTWELL REMOVAL

1. Remove the screws on the bottom of the footwell.
2. Remove the screws securing the footwell to the rear fender.
3. Use a flat screwdriver to remove the plastic rivets securing the footwell to the front fender.
4. Remove the footwell.

① Torx Head Screws

② Plastic Rivets

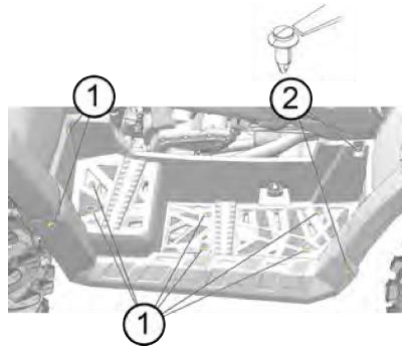

TIRES

⚠ WARNING

Operating your Tractor with worn tires, improperly inflated tires, non-standard tires or improperly installed tires will affect Tractor handling and could cause an accident resulting in serious injury or death. Always follow all tire maintenance procedures as outlined in this manual and on the labels on the Tractor. Always use original equipment size and type when replacing tires.

Refer to the specifications section for recommended tire type, size and pressure.

TIRE TREAD DEPTH

Always replace tires when tread depth is worn to 3 mm (1/8") or less.

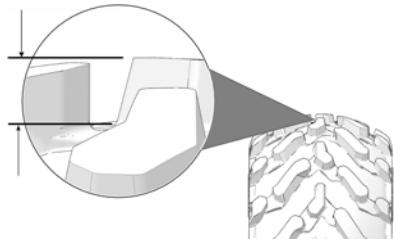



FRONT WHEEL HUB TIGHTENING

Front wheel bearing tightness and spindle nut retention are critical component operations. All service must be performed by your authorized dealer or other qualified service facility.

WHEEL NUT TORQUE SPECIFICATIONS

Check the wheel nut torques occasionally and when they've been loosened for service.

NUT TYPE		
Lug Nut (Aluminum Wheels)		4 KG PLUS 1/4 TURN
2-Piece Flange Nut (Steel Wheels)		3,7 KG

WHEEL REMOVAL / INSTALLATION

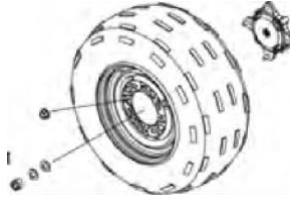

1. Position the Tractor on a level surface.
2. Place the transmission in PARK.
3. Loosen the wheel nuts slightly.
4. Elevate the end of the Tractor . See the Elevating the Tractor for Service section for details.
5. Remove the wheel nuts.
6. Remove the wheel.
7. Place the wheel on the hub.
8. install the wheel nuts finger tight.
9. Lower the Tractor to the ground.
10. Torque the wheel nuts to specification. See the Wheel Nut Torque Specifications section for torque values.

AIR FILTER

1. Remove the seat.
2. Release the air box cover clips and remove the air box cover.
3. Loosen the clamp and remove the filter.
4. Remove the fabric type pre-filter from the main filter. Wash the pre-filter in soapy water, then rinse and let dry.
5. Reinstall the pre-filter over the main filter. Install a new main filter if needed.
6. Reinstall the filter into the air box and tighten the clamp. Do not overtighten the clamp, as filter damage could occur.
7. Reinstall the air box cover and the seat.

- ① Pre-Filter
- ② Main Filter
- ③ Breather Valve
- ④ Breather Line

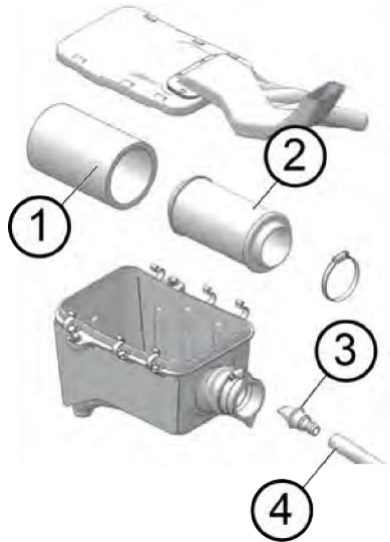

BREATHER VALVE/HOSE

The breather valve is on the hose that runs between the engine and air box.

1. Remove the left side panel.
2. Remove the hose clamps from the valve and pull the valve out of the hoses.
3. Inspect the valve for debris. Blow gently through the valve to check for clogging. Replace a damaged or clogged valve.
4. Check the hoses for cracks, deterioration, abrasion, or leaks. Replace as needed.
5. Reinstall the valve and hose clamps.

NOTICE

Operation of your Tractor without a breather valve can cause engine damage.

Always reinstall the breather valve after removing it for service.

LIGHTS

⚠ CAUTION

Poor lighting can result in reduced visibility when driving. Headlight and taillight lenses become dirty during normal operation. Clean headlights frequently and replace burned out headlamps promptly.

Always make sure lights are adjusted properly for best visibility.

HIGH BEAM ADJUSTMENT

The headlight beam can be adjusted slightly upward or downward. Use the following procedure to make the adjustment.

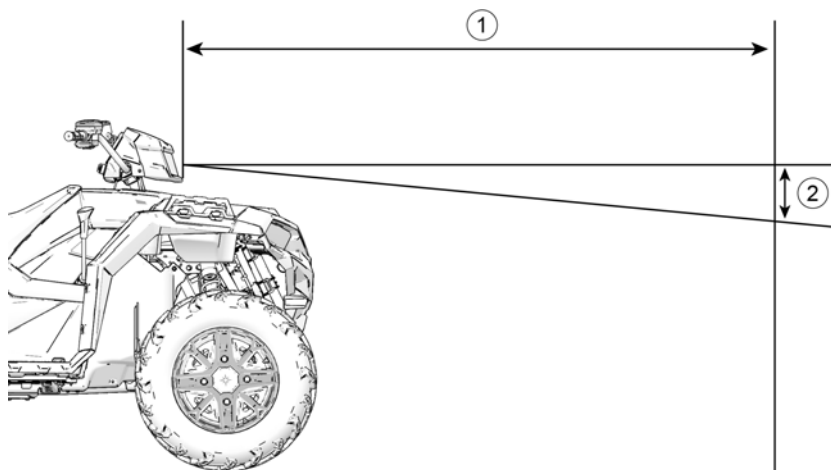

1. Position the Tractor on a level surface with the headlight approximately 7.6 m from a wall ①.
2. Place the transmission in PARK.
3. Measure the distance from the floor to the center of the headlight and make a mark on the wall at the same height.
4. Start the engine. Turn the headlight switch to high beam.

5. Observe the headlight aim on the wall. The most intense part of the headlight beam should be 5 cm below the mark on the wall. Include rider weight on the seat when measuring.
6. If adjustment is needed, the adjustment screw ① is located on the right side of the headlight pod. To adjust the beam, loosen the screw. Adjust the headlamp to the desired position, then tighten the screw.

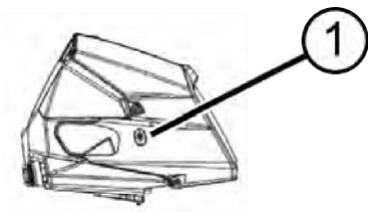

LOW BEAM ADJUSTMENT

To adjust the front headlights, do the following:

1. Place the Tractor on a level surface with the headlight approximately 7 meters from a wall.

NOTICE

Rider weight must be included on the seat while performing this procedure.
--

2. Place the transmission in PARK.
 3. Measure the distance from the floor to the center of the headlight and make a mark on the wall at the same height.
 4. Turn ignition ON and switch the headlight to low beam.
 5. Observe the headlight aim on the wall. The horizontal line, separating the lit-zone from the unlit-zone, should be aimed 20 cm below the mark placed on the wall in step 3.
-

6. Open the front rack.
7. If adjustment is needed, use the torx wrench tool included in the Tractor 's tool kit to adjust the headlight adjustment fasteners. Keep the most intense part of the headlight beam in the middle. When the lights are adjusted insert the compartment plug and close the front rack.

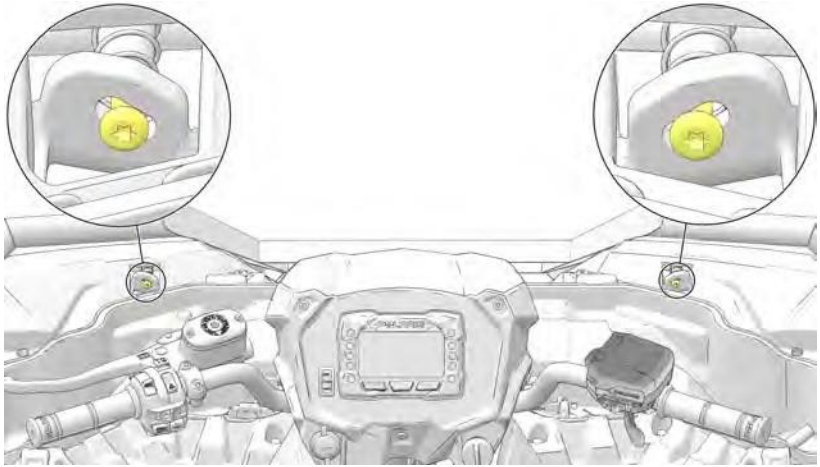

 **WARNING**

Due to the nature of ATVs and where they are operated, headlight lenses can become dirty. Frequent washing is necessary to maintain lighting quality. Riding with poor lighting can result in severe injury or death.

LOWER HEADLAMP REPLACEMENT

1. Turn the back of the headlight harness counter-clockwise and pull the harness assembly away from the headlight assembly.
2. Remove the headlamp and install the new headlamp.
3. Reinstall the harness assembly into the headlight assembly.
4. Turn the headlight harness clockwise to secure the headlamp.

- ① Phillips Screw
- ② Lamp
- ③ Harness

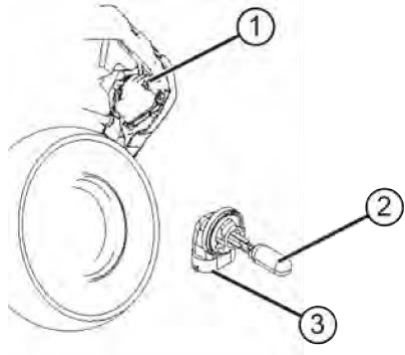

HEADLIGHT HOUSING REPLACEMENT



1. Remove the seven (7) headlight pod screws.
 2. Pull the pod cover forward.
 3. Unplug the headlamp from the wiring harness.
 4. Use a small screwdriver to remove the o-rings from the headlight mounting tabs.
 5. Pull the headlight housing up from the bracket for removal.
 6. Reverse the steps to install the new housing and reassemble the pod.
-

HEADLIGHT / POSITION LIGHT LAMP REPLACEMENT

When servicing a halogen lamp, do not touch the lamp with bare fingers. Oil from your skin leaves a residue, causing a hot spot that will shorten the life of the lamp. Hold the plastic part of the lamp.

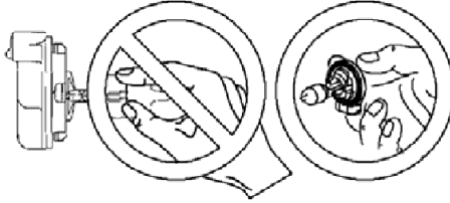

1. Place the transmission in PARK.
2. Open the front rack cover.
3. Remove the plug at the back of the headlight.
4. Pull the harness plug to disconnect it from the back of the headlight.

5. *Position light* ①: Rotate the socket to remove it. Go to step 6.

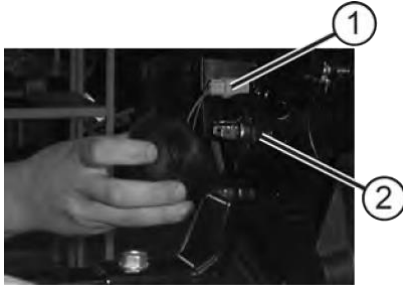

Headlamp ②: Reach under the bumper and remove the rubber cover from the back of the headlight. Turn the collar ③ counter-clockwise and carefully remove the collar and socket ④.

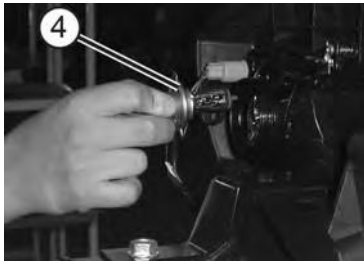
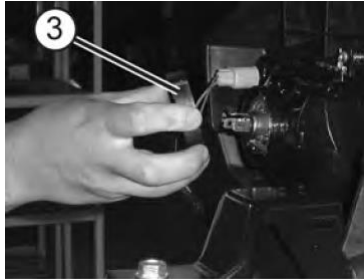

6. Remove the lamp. Apply dielectric grease to the socket and install a new lamp.
7. Reverse all steps to reassemble the headlight.
-

FRONT TURN SIGNAL LAMP REPLACEMENT

If a front turn signal light becomes inoperable, use a Phillips screwdriver to remove the lens cover screws. Remove the lens cover and replace the spent lamp with a new lamp. Always use a P21W (21 watt) lamp.

TAILLIGHT / BRAKELIGHT LAMP REPLACEMENT

1. Remove the harness connector from the back of the light assembly.
2. Turn the lamp counter-clockwise to remove it.
3. Apply dielectric grease to the socket and install the new lamp.
4. Reinstall the harness connector.
5. Test the light for proper operation.

① Taillight

② Harness Connector

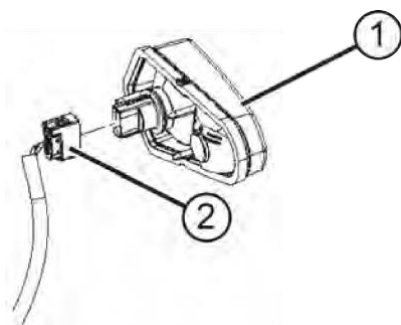

③ Lamp

④ Socket

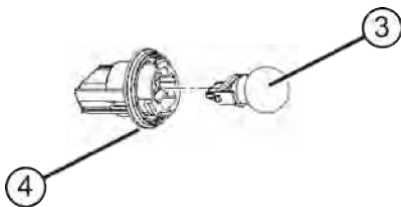

SPARK PLUGS

SPARK PLUG RECOMMENDATIONS

Refer to the Specifications section for the recommended spark plug type and gap for your Tractor .

NOTICE

Using non-recommended spark plugs can result in serious engine damage. Always use recommended spark plugs.

PLUG CONDITION	TORQUE SPECIFICATION
New Spark Plug	1,2 kg
Previously Installed Spark Plug	1,2 kg

SPARK PLUG INSPECTION

Spark plug condition is indicative of engine operation. Check the spark plug firing end condition after the engine has been warmed up and the Tractor has been driven at higher speeds. Immediately check the spark plugs for correct color.

CAUTION

A hot exhaust system and engine can cause burns. Wear protective gloves when removing a spark plug for inspection.

1. Rotate the spark plug cap 1/4 turn and pull it off the spark plug.
2. Rotate the spark plug counter-clockwise to remove it.
3. Reverse the procedure for spark plug installation. Torque to specification.

NORMAL SPARK PLUG

The normal insulator tip is gray, tan or light brown. There will be few combustion deposits. The electrodes are not burned or eroded. This indicates the proper type and heat range for the engine and the service.

The tip should not be flaky and white. A white insulator tip indicates overheating, caused by use of an improper spark plug or incorrect fuel.

WET FOULED SPARK PLUG

The wet fouled insulator tip is black. A damp oil film covers the firing end. There may be a carbon layer over the entire nose. Generally, the electrodes are not worn. General causes of fouling are excessive oil, use of non-recommended oil or incorrect throttle body adjustments.

SPARK PLUG REMOVAL

1. Remove the left-side panel. See the Footwell Removal section for details.
2. Remove the spark plug cap.
3. Use the spark plug wrench to remove the spark plug. Turn the plug counter-clockwise to remove it.
4. Inspect the electrodes for wear and carbon buildup. Replace worn or fouled plugs. Verify that the gap is at specification before installation.
5. Reinstall the spark plug. Torque to specification.
6. Reinstall the spark plug cap.

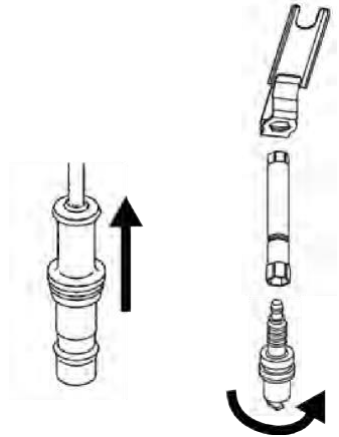

TRACTOR IMMERSION

If your Tractor becomes immersed, major engine damage can result if the machine is not thoroughly inspected. Take the Tractor to your dealer before starting the engine. If it's impossible to take your tractor to a dealer before starting it, follow the steps outlined below.

1. Move the Tractor to dry land or at the very least, to water below the footrests.
2. Check the air box. If water is present, dry the air box and replace the filter with a new filter.
3. Remove the spark plug.
4. Turn the engine over several times using the electric start.
5. Dry the spark plug. Reinstall the plug or install a new plug.
6. Attempt to start the engine. If necessary, repeat the drying procedure.
7. Take the Tractor to your dealer for service as soon as possible, whether you succeed in starting it or not.
8. If water has been ingested into the PVT, follow the procedure for drying out the PVT in the PVT Drying section.

SPARK ARRESTER

WARNING

Do not perform clean out immediately after the engine has been run, as the exhaust system becomes very hot. Serious burns could result from contact with exhaust components.

To reduce fire hazard, make sure that there are no combustibile materials in the area when purging the spark arrestor.
Wear eye protection.

Do not stand behind or in front of the Tractor while purging the carbon from the spark arrestor.

Never run the engine in an enclosed area. Exhaust contains poisonous carbon monoxide gas.

Do not go under the machine while it is inclined. Set the hand brake and block the wheels to prevent roll back.

Failure to heed these warnings could result in serious personal injury or death.

The exhaust pipe must be periodically purged of accumulated carbon as follows:

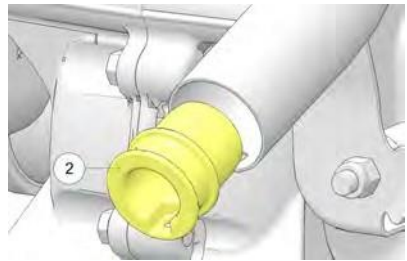
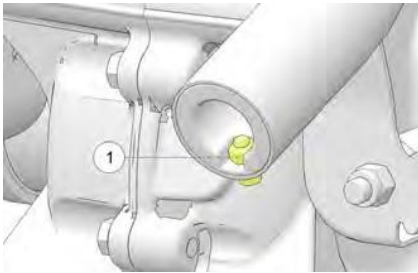

Periodically clean the spark arrester to remove accumulated carbon.

1. Place the transmission in PARK.
2. Remove the arrester retaining bolt and nut ①.
3. Remove the arrester from the end of the muffler ②.
4. Use non-synthetic brush to clean the arrester screen. A synthetic brush may melt if the components are warm. If necessary, blow debris from the screen with compressed air.
5. Inspect the screen for wear and damage. Replace a worn or damaged screen.
6. Reinstall the arrester.
7. Torque the bolt to specification.

TORQUE
1,2 kg

PVT SYSTEM

WARNING

Do not modify any component of the PVT system. Doing so may reduce its strength so that a failure may occur at a high speed. The PVT system has been precision balanced. Any modification will cause the system to be out of balance, creating vibration and additional loads on components.

The PVT system rotates at high speeds, creating large amounts of force on clutch components. Extensive engineering and testing has been conducted to ensure the safety of this product. However, as the owner, you have the following responsibilities to make sure this system remains safe:

- Always follow all recommended maintenance procedures. Always look for and remove debris inside and around the clutch and vent system when replacing the belt.
 - See your dealer as outlined in the owner's manual.
 - This PVT system is intended for use on POLARIS products only. Do not install it in any other product.
 - Always make sure the PVT housing is securely in place during operation.
-

WHEN TO USE LOW AND HIGH RANGE

CONDITION	RANGE TO USE
Operating at speeds less than 11 km/h	Low
Towing heavy loads	Low
Operating in rough terrain (swamps, mountains, etc.)	Low
Operating at speeds greater than 11 km/h	High

PVT DRYING

There may be some instances when water is accidentally ingested into the PVT system. Use the following instructions to dry it out before operating.

1. Position the Tractor on a level surface.
 2. Remove the drain plug. Allow the water to drain completely. Reinstall the drain plug.
 3. Start the engine. Place the transmission in PARK.
 4. Apply varying throttle for 10-15 seconds to expel the moisture and air-dry the belt and clutches. Do not hold the throttle wide open for more than 5 seconds.
 5. Allow the engine RPM to settle to idle speed, then shift the transmission to low range.
 6. Test for belt slippage. If the belt slips, repeat the process. Your Tractor requires service as soon as possible, which your authorized dealer can provide.
-

BATTERY **WARNING**

Improperly connecting or disconnecting battery cables can result in an explosion and cause serious injury or death. When removing the battery, always disconnect the negative (black) cable first. When reinstalling the battery, always connect the negative (black) cable last.

 **WARNING**

Battery electrolyte is poisonous. It contains sulfuric acid. Serious burns can result from contact with skin, eyes or clothing.

Antidote:

External: Flush with water.

Internal: Drink large quantities of water or milk. Follow with milk of magnesia, beaten egg, or vegetable oil. Call physician immediately.

Eyes: Flush with water for 15 minutes and get prompt medical attention.

Batteries produce explosive gases. Keep sparks, flame, cigarettes, etc. away. Ventilate when charging or using in an enclosed space. Always shield eyes when working near batteries. **KEEP OUT OF REACH OF CHILDREN.**

Your Tractor may have either a sealed battery, which requires little maintenance, or a conventional battery. A sealed battery can be identified by its flat covers on the top of the battery. A conventional battery has six filler caps on the top of the battery.

Always keep battery terminals and connections free of corrosion. If cleaning is necessary, remove corrosion with a stiff wire brush. Wash with a solution of one tablespoon baking soda and one cup water. Rinse well with tap water and dry off with clean shop towels. Coat the terminals with dielectric grease or petroleum jelly. Be careful not to allow cleaning solution or tap water into a conventional battery.

BATTERY INSTALLATION

Using a new battery that has not been fully charged can damage the battery and result in a shorter life. It can also hinder Tractor performance. Follow the battery charging instructions in the Battery Charging sections before installing the battery.

An optional extreme use battery may be available for your model. If the performance of the factory-installed battery is inadequate due to operation in extreme cold or due to extended use of multiple electrical accessories, please see your POLARIS dealer. Ask your dealer to provide any installation procedures that may differ for an extreme use battery.

 **WARNING**

Battery gases could accumulate in an improperly installed vent tube and cause an explosion, resulting in serious injury or death. Always ensure that the vent tube is free of obstructions and is securely installed as recommended.

1. Ensure that the battery is fully charged.
 2. Place the battery in the battery holder.
 3. With conventional batteries, install the battery vent tube (sealed batteries do not have a vent tube). The vent tube must be free of obstructions and securely installed. Route the tube away from the frame and Tractor body to prevent contact with electrolyte.
 4. On conventional batteries, coat the terminals with dielectric grease or petroleum jelly.
 5. Connect and tighten the red (positive) cable first.
 6. Connect and tighten the black (negative) cable last.
 7. Install the battery cover (if equipped).
 8. Secure the battery hold-down strap.
 9. Verify that cables are properly routed. Cables should be safely tucked away at the front and rear of the battery.
-

BATTERY REMOVAL

NOTICE

If electrolyte spills, immediately wash it off with a solution of one tablespoon baking soda and one cup water to prevent damage to the Tractor .

1. Disconnect the battery hold-down strap.
2. Remove the battery cover (if equipped).
3. On conventional batteries, remove the battery vent tube.
4. Disconnect the black (negative) battery cable first.
5. Disconnect the red (positive) battery cable last.
6. Lift the battery out of the ATV. Be careful not to tip a conventional battery sideways, which could spill electrolyte.

BATTERY STORAGE

Whenever the Tractor is not used for a period of three months or more, remove the battery from the Tractor , ensure that it's fully charged, and store it out of the sun in a cool, dry place. Check battery voltage each month during storage and recharge as needed to maintain a full charge.

We recommends maintaining battery charge by using a Battery Tender charger or by charging once a month using the battery tender port ①. Battery Tender can be left connected during the storage period, and will automatically charge the battery if the voltage drops below a pre-determined point. See the Products section for the part numbers.



BATTERY FLUID (CONVENTIONAL BATTERY)

A poorly maintained battery will deteriorate rapidly. Check the battery fluid level often. Maintain the fluid level between the upper ① and lower level ② marks.

Add only distilled water. Tap water contains minerals that are harmful to a battery.

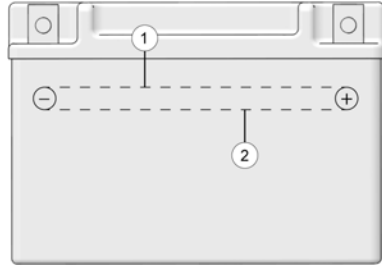

BATTERY CHARGING (CONVENTIONAL BATTERY)

1. Remove the battery from the Tractor to prevent damage from leaking or spilled electrolyte during charging.
2. Charge the battery with a charging output no larger than 1/10 of the battery's amp/hr rating. Charge as needed to raise the specific gravity to 1.270 or greater.
3. Reinstall the battery. Make sure the positive terminal is toward the front of the Tractor .

BATTERY CHARGING (SEALED BATTERY)

The following battery charging instructions apply only to the installation of a sealed battery. Read all instructions before proceeding with the installation of this battery.

The sealed battery is already filled with electrolyte and has been sealed and fully charged at the factory. Never pry the sealing strip off or add any other fluid to this battery.

The single most important thing about maintaining a sealed battery is to keep it fully charged. Since the battery is sealed and the sealing strip cannot be removed, you must use a voltmeter or multimeter to measure DC voltage.

⚠ WARNING

An overheated battery may explode, causing severe injury or death. Always watch charging times carefully. Stop charging if the battery becomes very warm to the touch. Allow it to cool before resuming charging.

For a refresh charge, follow all instructions carefully.

MAINTENANCE

1. Check the battery voltage with a voltmeter or multimeter. A fully charged battery will register 12.8 V or higher.
2. If the voltage is less than 12.8 volts, recharge the battery at 1.2 amps or less until battery voltage is 12.8 or greater.

TIP

When using an automatic charger, refer to the charger manufacturer's instructions for recharging. When using a constant current charger, use the guidelines below for recharging.

Always verify battery condition before and 1-2 hours after the end of charging.

STATE OF CHARGE	VOLTAGE	ACTION	CHARGE TIME*
100%	12.8-13.0 volts	None, check at 3 mos. from date of manufacture	None required
75%-100%	12.5-12.8 volts	May need slight charge, if no charge given, check in 3 months	3-6 hours
50%-75%	12.0-12.5 volts	Needs charge	5-11 hours
25%-50%	11.5-12.0 volts	Needs charge	At least 13 hours, verify state of charge
0%-25%	11.5 volts or less	Needs charge with desulfating charger	At least 20 hours

*(Using constant current charger @ standard amps specified on top of battery)

CLEANING AND STORAGE

WASHING THE TRACTOR

Keeping your POLARIS Tractor clean will not only improve its appearance but it can also extend the life of various components.

NOTICE

High water pressure may damage components. We recommends washing the Tractor by hand or with a garden hose, using mild soap. Certain products, including insect repellents and chemicals, will damage plastic surfaces. Do not allow these types of products to contact the Tractor .

The best and safest way to clean your Tractor is with a garden hose and a pail of mild soap and water.

1. Use a professional-type washing cloth, cleaning the upper body first and the lower parts last.
2. Rinse with clean water frequently.
3. Dry surfaces with a chamois to prevent water spots.

WASHING TIPS

- Avoid the use of harsh cleaners, which can scratch the finish.
- Do not use a power washer to clean the Tractor .
- Do not use medium to heavy duty compounds on the finish.
- Always use clean cloths and pads for cleaning and polishing. Old or reused cloths and pads may contain dirt particles that will scratch the finish.

If a high pressure water system is used for cleaning (not recommended), exercise extreme caution. The water may damage components and could remove paint and decals. Avoid directing the water stream at the following items:

- Wheel bearings
 - Radiator
 - Transmission seals
 - Cab and body panels
 - Electrical components
 - Switches and controls
 - Fuel system components
 - Labels and decals
-

If an informational or graphic label becomes illegible or comes off, contact your dealer to purchase a replacement. Replacement *safety* labels are provided at no charge.

Grease all zerk fittings immediately after washing. Allow the engine to run for a while to evaporate any water that may have entered the engine or exhaust system.

POLISHING THE TRACTOR

We recommends the use of common household aerosol furniture polish for polishing the finish on your Tractor. Follow the instructions on the container.

POLISHING TIPS

- Avoid the use of automotive products, some of which can scratch the finish of your Tractor .
- Always use clean cloths and pads for cleaning and polishing. Old or reused cloths and pads may contain dirt particles that will scratch the finish.

CHROME WHEEL CARE (IF EQUIPPED)

Proper maintenance will protect chrome wheels from corrosion, preserve wheel life and ensure a "like new" appearance for many years. Chrome wheels exposed to road salt (or salt in the air in coastal areas) are more susceptible to corrosion if not properly cleaned. Clean chrome wheels more often if they're exposed to salt or other corrosive elements.

1. Wash chrome wheels frequently. Use a mild detergent. Never use abrasive cleaners on plated or painted surfaces.
2. Rinse well with clear water. Soap, detergents, salt, dirt, mud, and other elements can cause corrosion.
3. Polish the clean chrome wheels periodically. Use an automotive grade chrome polish.
4. Routinely and liberally apply a weather resistant wax to each polished chrome wheel. Choose a product suitable for chrome finishes. Read and follow the product labels and instructions.

REMOVING CORROSION

If light rust is found on the chrome finish, use steel wool to remove it.

Gently rub the affected areas with the steel wool until the corrosion has been removed. Clean and polish the wheel as outlined above.

STORAGE TIPS

NOTICE

Starting the engine during the storage period will disturb the protective film created by fogging and damage could occur. Never start the engine during the storage period.

CLEAN THE EXTERIOR

Make any necessary repairs and clean the Tractor as recommended. See the Washing the Tractor section.

STABILIZE THE FUEL

1. Fill the fuel tank.
2. Add Carbon Clean Fuel Treatment or Fuel Stabilizer or equivalent fuel treatments or stabilizers. Follow the instructions on the container for the recommended amount. Carbon Clean removes water from fuel systems, stabilizes fuel and removes carbon deposits from pistons, rings, valves and exhaust systems.
3. Allow the engine to run for 15-20 minutes to allow the stabilizer to disperse through the entire fuel delivery system.

OIL AND FILTER

Change the oil and filter. See the Engine Oil section.

AIR FILTER / AIR BOX

1. Inspect and clean (or replace) the pre-cleaner and air filter. See the Air Filter section.
2. Clean the air box.

FLUID LEVELS

Inspect the fluid levels. Add or change fluids as recommended in the Periodic Maintenance Chart.

- Demand drive fluid (front gearcase)
 - Rear gearcase fluid (if equipped)
 - Transmission fluid
 - Brake fluid (change every two years and any time the fluid looks dark or contaminated)
 - Coolant (test strength/fill)
-

FOG THE ENGINE

1. Treat the fuel system with POLARIS Carbon Clean or other equivalent fuel treatment. Follow the instructions on the container. Start the engine. Allow it to idle for several minutes so the Carbon Clean reaches the injectors. Stop the engine.
2. Remove the spark plugs and add 30 cc. of engine oil.
To access the plug holes, use a section of clear 6 mm hose and a small plastic squeeze bottle filled with the pre-measured amount of oil. *Do this carefully! If you miss the plug holes, oil will drain from the spark plug cavities into the hole at the front of the cylinder head, and appear to be an oil leak.*
3. Reinstall the spark plugs. Torque to specification.
4. Apply dielectric grease to the inside of each spark plug cap. *Do not reinstall the cap onto the plug at this step.*
5. Turn the engine over several times. Oil will be forced in and around the piston rings and ring lands, coating the cylinder with a protective film of fresh oil.
6. Reinstall the spark plug caps.
7. If fuel system additive is not used, fuel tank, fuel lines, and injectors should be completely drained of gasoline.

INSPECT AND LUBRICATE

Inspect all cables and lubricate all areas of the Tractor as recommended in the Periodic Maintenance Chart.

BATTERY MAINTENANCE

Remove the battery and recharge it as outlined in the Battery Charging section. Store the battery in a cool, dry place.

STORAGE AREA / COVERS

Set the tire pressure and safely support the Tractor with the tires slightly off the ground. Be sure the storage area is well ventilated. Cover the Tractor with a genuine cover. Do not use plastic or coated materials. They do not allow enough ventilation to prevent condensation, and may promote corrosion and oxidation.

ACCESSORIES

Auxiliary power outlets provide 12-volt power for operating accessories. Accessory outlets are available for all models, also has a wide range of additional accessories available for your Tractor. Always install accessories that are approved for Tractor use. Your dealer can assist.

PRODUCTS

LUBRICANTS / MISCELLANEOUS

PART NUMBER	DESCRIPTION
Engine Lubricant	
2870791	Fogging Oil (Aerosol)
2876244	PS-4 Full Synthetic 5W-50 4-Cycle Oil (.95 L)
2876245	PS-4 Full Synthetic 5W-50 4-Cycle Oil (3.8 L)
2878920	PS-4 Extreme Duty Synthetic 10W-50 4-Cycle Oil (.95 L)
2878919	PS-4 Extreme Duty Synthetic 10W-50 4-Cycle Oil (3.8 L)
Gearcase / Transmission Lubricants	
2878068	AGL Full Synthetic Gearcase Lubricant & Transmission Fluid (.95 L)
2878069	AGL Full Synthetic Gearcase Lubricant & Transmission Fluid (3.8 L)
2877922	Demand Drive Plus Fluid (.95 L)
2877923	Demand Drive Plus Fluid (3.8 L)
2870465	Pump for 3.8 L Jug
Coolant	
2880514	Antifreeze 50/50 Premix (.95 L)
2880513	Antifreeze 50/50 Premix (3.8 L)
Grease / Specialized Lubricants	
2871312	Grease Gun Kit, Premium All Season
2871322	All Season Grease (0.9 liter cartridge)
2871423	All Season Grease (0,4 liter cartridge)
2871460	Premium Starter Grease

POLARIS PRODUCTS

2871515	U-Joint Grease (89 ml cartridge)
---------	----------------------------------



POLARIS PRODUCTS

PART NUMBER	DESCRIPTION
2871551	U-Joint Grease (0.4 liter cartridge)
2871329	Dielectric Grease (Nyogel®)
Additives / Miscellaneous	
2871326	Carbon Clean
2870652	Fuel Stabilizer
2872189	DOT 4 Brake Fluid
2871956	Loctite® 565 Thread Sealant
2859044	Battery Tender® Charger

SPECIFICATIONS

SPORTSMAN 570 6X6

Maximum Weight Capacity load on the Tractor ,Including, operator ,cargo box front, Cargo box rear, rear hitch vertical weight & accessories	500 kg
Dry Weight (+/- 7% based on configuration)	520 kg
Front Rack Capacity	40 kg
Cargo Box Capacity	340 kg
Maximum Hitch Vertical Load	40 kg
Pulling capacity with inertia braked trailer	1100 kg
Overall Length	2950 mm
Overall Width	1330 mm
Overall Height	1270 mm
Wheelbase front to rear	2135 mm
Ground Clearance	280 mm
Minimum Turning Radius	4966 mm unloaded
Fuel Capacity	25.5 L
Engine Oil Capacity	1.9 L
Coolant Capacity	2.5 L
Transmission Oil Capacity	1 L
Demand Drive (Front Gearcase) Fluid Capacity	0,3 L
Rear Gearcase Oil Capacity	0,15 L
Engine	Dual overhead cam, 4 valve 4 stroke single cylinder
Displacement	567 cc
Bore x Stroke	99 mm x 73.6 mm
Alternator Output	660 W @ 7000 RPM
Compression Ratio	10:1

SPECIFICATIONS

Starting System	Electric
Fuel System	Electronic Fuel Injection
Ignition System	ECU
Spark Plug / Gap	NGK® MR7F / 0.7-0.8 mm
Lubrication System	Wet Sump
Driving System Type	Automatic PVT (POLARIS Variable Transmission)
Front Suspension	MACPHERSON RIDE® strut with 21 cm travel
Rear Suspension	Progressive rate with 24 cm travel
Transmission	H/L/N/R/P
Gear Reduction, Low	23.91:1
Gear Reduction, Reverse	21.74:1
Gear Reduction, High	10.57:1
Drive Ratio, Front	3.82:1
Tires size /Pressure, Front 2 x	26x8-12 46F / 0,8 Bar
Tires size /Pressure, Rear 4 x	26x11-12 55F / 0,8 Bar
Brake, Hand	Single-Control Hydraulic Disc
Brake, Foot	Foot-Activated Hydraulic Disc
Brake, Parking	Transmission park lock and hydraulic lock, all wheel
Winch	Front permanent installed winch with 1.125 kg capacity
Headlight	2 dual beam on bumper (55/60 watt) 1 single beam on headlight pod (50 watt)
Work Lights	50 watts
Parking Lights	5 watts
Taillights	8.26 watts
Brake Light	26.9 watts
Instrument Cluster	LCD

CLUTCHING CHART

For more information about clutching options, please see your authorized dealer.

Altitude in meters (feet)	Shift Weight	Drive Clutch Spring	Driven Clutch Spring	Helix
0-1800 (0-6000)	25-52G PN 5632409	Black PN 7043594	Red PN 3234451	EBS PN 3235639
1800-3700 (6000-12000)	N/A	Black PN 7043594	Red PN 3234451	EBS PN 3235639

TROUBLESHOOTING

DRIVE BELT WEAR / BURN

POSSIBLE CAUSE	SOLUTION
Driving onto a pickup or tall trailer in high range	Use low range during loading.
Starting out going up a steep incline	Use low range or turn around using the K-turn. See the Turning Around on a Hill section.
Driving at too low RPM or ground speed 5 kmh	Drive at a higher speed or use low range more frequently. See the When To Use Low Range and High Range section.
Insufficient warm-up at low ambient temperatures	Warm the engine at least 5 minutes. With the transmission in neutral, advance the throttle to about 1/8 throttle in short bursts, 5 to 7 times. The belt will become more flexible and prevent belt burning.
Slow/easy clutch engagement	Use the throttle quickly and effectively.
Towing/pushing at low RPM/low ground speed	Use low range only.
Utility use/plowing	Use low range only.
Stuck in mud or snow	Shift the transmission to low range and carefully use fast, aggressive throttle application to engage clutch. WARNING! Excessive throttle may cause loss of control and Tractor overturn.
Climbing over large objects from a stopped position	Shift the transmission to low range and carefully use fast, brief, aggressive throttle application to engage clutch. WARNING! Excessive throttle may cause loss of control and Tractor overturn.
Belt slippage from water or snow ingestion into the PVT system	Dry out the PVT. See the PVT Drying section. Inspect clutch seals for damage if repeated leaking occurs.
Clutch malfunction	See your dealer.

TROUBLESHOOTING

POSSIBLE CAUSE	SOLUTION
Poor engine performance	Check for fouled plugs or foreign material in gas tank or fuel lines. See your dealer.
Slippage from failure to warm up belt	Always warm up the belt by operating below 30 mph for one mile (5 miles or more when temperature is below freezing).
Wrong or missing belt	Install the recommended belt.
Improper break-in	Always break in a new belt and/or clutch. See the PVT Break-in (Clutches / Belt) section.
Low battery voltage	Recharge the battery to 12.8 VDC
Loose battery connections	Check all connections and tighten
Loose solenoid connections	Check all connections and tighten

ENGINE TURNS OVER, FAILS TO START

POSSIBLE CAUSE	SOLUTION
Out of fuel	Refuel.
Water is present in fuel	Drain the fuel system and refuel.
Old or non-recommended fuel	Replace with fresh recommended fuel.
Fouled or defective spark plug	Inspect plug and replace if necessary.
No spark to spark plug	Inspect plug and replace if necessary.
Water or fuel in crankcase	Your authorized dealer can assist.
Low battery voltage	Recharge the battery to 12.8 VDC.
Mechanical failure	Your authorized dealer can assist.

ENGINE BACKFIRES

POSSIBLE CAUSE	SOLUTION
Weak spark from spark plug	Inspect, clean and/or replace spark plug
Incorrect spark plug gap or heat range	Set gap to specs or replace plug
Old or non-recommended fuel	Replace with fresh recommended fuel
Incorrectly installed spark plug wires	Your authorized dealer can assist
Mechanical failure	Your authorized dealer can assist
Loose ignition connections	Check all connections and tighten
Water present in fuel	Replace with fresh recommended fuel

ENGINE PINGS OR KNOCKS

POSSIBLE CAUSE	SOLUTION
Poor quality or low octane fuel	Replace with recommended fuel.
Incorrect ignition timing	Your authorized dealer can assist.
Incorrect spark plug gap or heat range	Set gap to specs or replace plugs.

ENGINE RUNS IRREGULARLY, STALLS OR MISFIRES

POSSIBLE CAUSE	SOLUTION
Fouled or defective spark plug(s)	Inspect, clean and/or replace spark plugs
Worn or defective spark plug wires	Your authorized dealer can assist
Incorrect spark plug gap or heat range	Set gap to specs or replace plugs
Loose ignition connections	Check all connections and tighten
Water present in fuel	Replace with new fuel
Low battery voltage	Recharge battery to 12.8 VDC

TROUBLESHOOTING

POSSIBLE CAUSE	SOLUTION
Kinked or plugged fuel tank vent line	Inspect and replace
Incorrect fuel	Replace with recommended fuel
Clogged air filter	Inspect and clean or replace
Reverse speed limiter malfunction	Your authorized dealer can assist
Electronic throttle control malfunction	Your authorized dealer can assist
Other mechanical failure	Your authorized dealer can assist

POSSIBLE LEAN FUEL CAUSE	SOLUTION
Low or contaminated fuel	Add or change fuel, clean the fuel system
Kinked or plugged fuel tank vent line	Inspect and replace
Low octane fuel	Replace with recommended fuel
Clogged air filter	Your authorized dealer can assist
Incorrect fuel	Replace with recommended fuel

POSSIBLE RICH FUEL CAUSE	SOLUTION
Fuel is very high octane	Replace with lower octane fuel
Stopping/starting without adequate warm-up	Allow engine to warm up before operating and/or stopping
Incorrect fuel	Replace with recommended fuel
Clogged air filter	Inspect and clean or replace

ENGINE STOPS OR LOSES POWER

POSSIBLE CAUSE	SOLUTION
Out of fuel	Refuel, cycle key to ON position three times for 5 seconds each, then start
Kinked or plugged fuel vent line	Inspect and replace
Water is present in fuel	Replace with new fuel
Fouled or defective spark plug(s)	Inspect, clean and/or replace spark plugs
Worn or defective spark plug wires	Your authorized dealer can assist
Incorrect spark plug gap or heat range	Set gap to specs or replace plug
Loose ignition connections	Check all connections and tighten
Low battery voltage	Recharge the battery to 12.8 VDC
Incorrect fuel	Replace with fresh recommended fuel
Clogged air filter	Inspect and clean or replace
Reverse speed limiter malfunction	Your authorized dealer can assist
Electronic throttle control malfunction	Your authorized dealer can assist
Other mechanical failure	Your authorized dealer can assist
Overheated engine	Clean radiator screen and core, clean engine exterior. Your dealer can assist.

ENGINE OVERHEATING

POSSIBLE CAUSE	SOLUTION
Debris lodged in screen	Clean the screen
Plugged Radiator	Use a garden hose to flush any debris from the radiator fins. NOTE: High pressure washers can deform the radiator fins and reduce cooling efficiency.

DIAGNOSTIC DISPLAY CODE DEFINITIONS

Open Load: There is a break in the wires that lead to the item listed in the chart (injector, fuel pump, etc.), or the item has failed.

Short-to-Ground: The wire is shorted to ground between the electronic control unit and the item listed in the chart.

Shorted Load: The wires leading to the item listed in the chart are shorted together, or the item has shorted internally.

Short-to-Battery: The wire leading from the item listed in the chart to the electronic control unit is shorted to a wire at battery voltage.

DIAGNOSTIC CODES			
COMPONENT	CONDITION	SPN	FMI
Accelerator Position 2	Data Valid But Above Normal Operational Range	29	0
	Not Plausible		2
	Voltage Too High		3
	Voltage Too Low		4
Throttle Position Sensor 1	Data Valid But Above Normal Operational Range	51	0
	Data Valid But Below Normal Operational Range		1
	Signal Out of Range		2
	Voltage Too High		3
	Voltage Too Low		4

TROUBLESHOOTING

DIAGNOSTIC CODES			
COMPONENT	CONDITION	SPN	FMI
	Abnormal Rate Of Change		10
	Out Of Calibration		13
Tractor Speed Sensor	Data Valid But Above Normal Operational Range	84	0
	Data Valid But Below Normal Operational Range		1
	Data Erratic or Intermittent (or missing)		2
	Voltage Too High		3
	Voltage Below Normal, Or Shorted To Low Source		4
	Abnormal Frequency Or Pulse Width Or Period		8
	Abnormal Update Rate		9
	Abnormal Rate Of Change		10
	Bad Intelligent Device Or Component		12
	Received Tractor Speed Has Error		19
Accelerator Position 1	Voltage Too High	91	3
	Voltage Too Low		4
Fuel Level Signal	Data Erratic, Intermittent Or Incorrect	96	2
	Voltage Above Normal, Or Shorted To High Source		3
	Voltage Too Low		4

TROUBLESHOOTING

DIAGNOSTIC CODES			
COMPONENT	CONDITION	SPN	FMI
	Data Valid But Above Normal Operating Range		16
	Data Valid But Below Normal Operating Range		18
Manifold Absolute Pressure Sensor	Data Erratic, Intermittent Or Incorrect	102	2
	Voltage Above Normal, Or Shorted To High Source		3
	Voltage Too Low		4
	Mechanical System Not Responding Or Out Of Adjustment		7
	Abnormal Rate Of Change		10
Intake Air Temperature Sensor (T-MAP)	Data Valid But Above Normal Operational Range - Most Severe Level	105	0
	Data Erratic, Intermittent Or Incorrect		2
	Voltage Too High		3
	Voltage Too Low		4
	Abnormal Rate Of Change		10
	Data Valid But Above Normal Operating Range		15
Intake Air Pressure Sensor	Data Valid But Above Normal Operational Range	106	0
	Data Valid But Below Normal Operational Range		1

TROUBLESHOOTING

DIAGNOSTIC CODES			
COMPONENT	CONDITION	SPN	FMI
	Data Erratic, Intermittent Or Incorrect		2
	Voltage Too High		3
	Voltage Too Low		4
Barometric Pressure Sensor	Data Erratic, Intermittent Or Incorrect	108	2
	Voltage Above Normal, Or Shorted To High Source		3
	Voltage Below Normal, Or Shorted To Low Source		4
	Abnormal Rate Of Change		10
Engine Temperature Sensor	Engine Overheat Shutdown	110	0
	Data Erratic, Intermittent Or Incorrect		2
	Voltage Too High		3
	Voltage Too Low		4
	Abnormal Rate Of Change		10
	Data Valid But Above Normal Operating Range		15
	Temperature Too High		16
	Data Valid But Below Normal Operating Range		17
	Received Network Data In Error		19
Battery Potential	Voltage Above Normal, Or Shorted To High Source	158	3

TROUBLESHOOTING

DIAGNOSTIC CODES			
COMPONENT	CONDITION	SPN	FMI
	Voltage Below Normal, Or Shorted To Low Source		4
Transmission Range	Invalid	162	2
System Power	Data Valid But Above Normal Operational Range - Most Severe Level	168	0
	Data Valid But Below Normal Operational Range - Most Severe Level		1
	Data Erratic, Intermittent Or Incorrect		2
	Voltage Too High		3
	Voltage Too Low		4
	Data Valid But Above Normal Operating Range - Moderately Severe Level		16
	Data Valid But Below Normal Operating Range - Moderately Severe Level		18
Engine Speed	Data Valid But Above Normal Operational Range - Most Severe Level	190	0
	Data Valid But Below Normal Operational Range - Most Severe Level		1
	Data Erratic, Intermittent Or Incorrect		2
	Mechanical System Not Responding Or Out Of Adjustment		7
	Received Engine Speed Has Error		19

TROUBLESHOOTING

DIAGNOSTIC CODES			
COMPONENT	CONDITION	SPN	FMI
	Error in Engine Speed Computation		31
Gear Sensor Signal	Data Erratic, Intermittent Or Incorrect	523	2
	Voltage Above Normal, Or Shorted To High Source		3
	Voltage Too Low		4
	Abnormal Update Rate		9
	Root Cause Not Known		11
Transmission Requested Gear	Received Network Data In Error	525	19
Cruise Control Panel Switches	Condition Exists	527	31
Brake Switch	Data Erratic, Intermittent Or Incorrect	597	2
	Abnormal Update Rate		9
	Abnormal Rate Of Change		10
	Received Network Data In Error		19
System Voltage	Data Valid But Above Normal Operating Range - Least Severe Level	627	15
	Data Valid But Below Normal Operating Range - Least Severe Level		17
ECU Memory	Bad Intelligent Device Or Component	628	12
	Out Of Calibration		13
Calibration	Out Of Calibration	630	13

TROUBLESHOOTING

DIAGNOSTIC CODES			
COMPONENT	CONDITION	SPN	FMI
	Checksum/CRC Error		19
Crankshaft Position Sensor	Plausibility Fault	636	2
	Abnormal Frequency Or Pulse Width Or Period		8
Camshaft Position Sensor	Mechanical System Not Responding Or Out Of Adjustment	637	7
	Abnormal Frequency Or Pulse Width Or Period		8
Injector 1 (MAG)	Voltage Below Normal / Shorted To Low Source / Driver Circuit Grounded.	651	4
	Current Below Normal / Open Circuit / Driver Circuit Open / Grounded		5
Injector 2 (PTO)	Voltage Above Normal, Or Shorted To High Source / Driver Circuit Short to B+	652	3
	Voltage Below Normal, Or Shorted To Low Source / Driver Circuit Grounded		4
	Current Below Normal Or Open Circuit / Driver Circuit Open / Grounded		5
Starter Solenoid Driver Circuit	Voltage Above Normal, Or Shorted To High Source	677	3
	Voltage Below Normal, Or Shorted To Low Source		4
	Current Below Normal Or Open Circuit		5

TROUBLESHOOTING

DIAGNOSTIC CODES			
COMPONENT	CONDITION	SPN	FMI
Rear Differential Output (Turf)	Driver Circuit Short to B+	746	3
	Driver Circuit Grounded		4
	Driver Circuit Open / Grounded		5
Fan Relay Driver Circuit	Voltage Above Normal	1071	3
	Voltage Below Normal		4
	Current Below Normal Or Open Circuit		5
Ignition Coil Primary Driver 1 (MAG)	Voltage Above Normal	1268	3
	Voltage Below Normal		4
	Current Below Normal Or Open Circuit		5
Starter Enable Circuit	Voltage Above Normal	1321	3
	Voltage Below Normal		4
	Current Below Normal Or Open Circuit		5
Fuel Pump Driver Circuit	Voltage Above Normal	1347	3
	Voltage Below Normal		4
	Current Below Normal Or Open Circuit		5
	Abnormal Frequency Or Pulse Width Or Period		8
EFI Relay Control Circuit	Voltage Above Normal	1485	3
	Voltage Below Normal		4

TROUBLESHOOTING

DIAGNOSTIC CODES			
COMPONENT	CONDITION	SPN	FMI
	Current Below Normal Or Open Circuit		5
Fan Driver 2	Voltage Above Normal	1557	3
	Voltage Below Normal, Or Shorted To Low Source		4
	Current Below Normal Or Open Circuit		5
PTO Solenoid Driver Circuit	Voltage Above Normal, Or Shorted To High Source	1888	3
	Voltage Below Normal, Or Shorted To Low Source		4
	Current Below Normal Or Open Circuit		5
Tractor Speed	Data Valid But Above Normal Operating Range - Moderately Severe Level	2590	16
Oxygen Sensor Bank 1 Sensor 1	Data Erratic, Intermittent Or Incorrect	3056	2
	Voltage Above Normal, Or Shorted To High Source		3
	Voltage Below Normal, Or Shorted To Low Source		4
	Bad Intelligent Device Or Component		12
	Data Valid But Below Normal Operating Range - Least Severe Level		17
ECU Output Supply Voltage 1	Data Valid But Above Normal Operational Range - Most Severe Level	3597	0

TROUBLESHOOTING

DIAGNOSTIC CODES			
COMPONENT	CONDITION	SPN	FMI
	Data Valid But Below Normal Operational Range - Most Severe Level		1
	Voltage Above Normal, Or Shorted To High Source		3
	Voltage Below Normal, Or Shorted To Low Source		4
	Data Valid But Above Normal Operating Range - Moderately Severe Level		16
	Data Valid But Below Normal Operating Range - Moderately Severe Level		18
ECU Output Supply Voltage 2	Data Valid But Above Normal Operational Range - Most Severe Level	3598	0
	Data Valid But Below Normal Operational Range - Most Severe Level		1
	Voltage Above Normal, Or Shorted To High Source		3
	Voltage Below Normal, Or Shorted To Low Source		4
	Data Valid But Above Normal Operating Range - Moderately Severe Level		16
	Data Valid But Below Normal Operating Range - Moderately Severe Level		18
ECU Output Supply Voltage 3	Data Valid But Above Normal Operational Range - Most Severe Level	3599	0

TROUBLESHOOTING

DIAGNOSTIC CODES			
COMPONENT	CONDITION	SPN	FMI
	Data Valid But Below Normal Operational Range - Most Severe Level		1
	Voltage Above Normal, Or Shorted To High Source		3
	Voltage Below Normal, Or Shorted To Low Source		4
	Data Valid But Above Normal Operating Range - Moderately Severe Level		16
	Data Valid But Below Normal Operating Range - Moderately Severe Level		18
CAN1 Bus Hardware	Root Cause Not Known	65559	11
	Condition Exists		31
ETC Accelerator Position Sensor Correlation	Data Erratic, Intermittent Or Incorrect	65613	2
Cylinder Misfire	Mechanical System Not Responding Or Out Of Adjustment	65590	7
Cylinder 1 Misfire	Mechanical System Not Responding Or Out Of Adjustment	65591	7
ETC Accelerator Position Sensor Outputs 1 & 2 Correlation	Data Erratic, Intermittent Or Incorrect	65613	2
CAN 1	Abnormal Update Rate	516125	9
Idle Engine speed	Received Network Data In Error	516178	19
Winch In Commanded State	Data Valid But Below Normal Operational Range - Most Severe Level	516246	1

TROUBLESHOOTING

DIAGNOSTIC CODES			
COMPONENT	CONDITION	SPN	FMI
	Voltage Above Normal, Or Shorted To High Source		3
	Voltage Below Normal, Or Shorted To Low Source		4
Winch Out Commanded State	Voltage Above Normal, Or Shorted To High Source	516247	3
	Voltage Below Normal, Or Shorted To Low Source		4
Winch Auto Stop Signal	Voltage Below Normal, Or Shorted To Low Source	516248	4
Plowing In High Range	Data Valid But Above Normal Operating Range - Moderately Severe Level	516249	16
CAN1 Bus Wiring	Condition Exists	520141	31
Throttle Release Signal	Data Erratic, Intermittent Or Incorrect	520194	2
	Voltage Above Normal, Or Shorted To High Source		3
	Voltage Below Normal, Or Shorted To Low Source		4
	Mechanical System Not Responding Or Out Of Adjustment		7
Throttle Position Sensor 2	Data Valid But Above Normal Operational Range - Most Severe Level	520198	0
	Data Valid But Below Normal Operational Range - Most Severe Level		1

TROUBLESHOOTING

DIAGNOSTIC CODES			
COMPONENT	CONDITION	SPN	FMI
	Voltage Above Normal, Or Shorted To High Source		3
	Voltage Below Normal, Or Shorted To Low Source		4
	Abnormal Rate Of Change		10
	Out Of Calibration		13
Canister Purge Valve	Voltage Above Normal, Or Shorted To High Source	520202	3
	Voltage Below Normal, Or Shorted To Low Source		4
	Current Below Normal Or Open Circuit		5
Front Wheel Back Drive (Active Descent System)	Voltage Above Normal, Or Shorted To High Source	520203	3
	Voltage Below Normal, Or Shorted To Low Source		4
	Current Below Normal Or Open Circuit		5
Fuel Correction Front	Data Valid But Above Normal Operating Range - Least Severe Level	520204	15
	Data Valid But Below Normal Operating Range - Least Severe Level		17
Fuel Correction Rear	Data Valid But Above Normal Operating Range - Least Severe Level	520205	15
	Data Valid But Below Normal Operating Range - Least Severe Level		17

TROUBLESHOOTING

DIAGNOSTIC CODES			
COMPONENT	CONDITION	SPN	FMI
Reverse Alarm	Data Erratic, Intermittent Or Incorrect	520206	2
	Voltage Above Normal, Or Shorted To High Source		3
	Voltage Below Normal, Or Shorted To Low Source		4
	Current Below Normal Or Open Circuit		5
All Wheel Drive Control Circuit	Voltage Above Normal, Or Shorted To High Source	520207	3
	Voltage Below Normal, Or Shorted To Low Source		4
	Current Below Normal Or Open Circuit		5
Chassis Relay	Voltage Above Normal, Or Shorted To High Source	520208	3
	Voltage Below Normal, Or Shorted To Low Source		4
	Current Below Normal Or Open Circuit		5
Idle Speed	Voltage Above Normal, Or Shorted To High Source	520211	3
	Voltage Below Normal, Or Shorted To Low Source		4
Accessory Relay	Voltage Above Normal, Or Shorted To High Source	520219	3
	Voltage Below Normal, Or Shorted To Low Source		4
	Current Below Normal Or Open Circuit		5

TROUBLESHOOTING

DIAGNOSTIC CODES			
COMPONENT	CONDITION	SPN	FMI
Battery Charge Relay	Voltage Above Normal, Or Shorted To High Source	520220	3
	Voltage Below Normal, Or Shorted To Low Source		4
	Current Below Normal Or Open Circuit		5
Steering Over Current Shut Down	Current Above Normal Or Grounded Circuit	520221	6
	Bad Intelligent Device Or Component		12
Steering Excessive Current Error	Current Above Normal Or Grounded Circuit	520222	6
Steering Torque Partial Failure	Condition Exists	520223	31
Steering Torque Full Failure	Condition Exists	520224	31
EPS Inverter Temperature	Data Valid But Above Normal Operational Range - Most Severe Level	520225	0
	Bad Intelligent Device Or Component		12
	Data Valid But Above Normal Operating Range - Moderately Severe Level		16
EPS Communications Receive Data Error	Data Erratic, Intermittent Or Incorrect	520226	2
	Condition Exists		31
EPS CAN Communications Transmit Error	Data Erratic, Intermittent Or Incorrect	520227	2
Position Encoder Error	Root Cause Not Known	520228	11

TROUBLESHOOTING

DIAGNOSTIC CODES			
COMPONENT	CONDITION	SPN	FMI
	Bad Intelligent Device Or Component		12
	Condition Exists		31
Software Error	Bad Intelligent Device Or Component	520229	12
	Condition Exists		31
IC CAN Communication with EPS	Condition Exists	520230	31
EPS Power Save Condition	Condition Exists	520231	31
Fuel Pull Solenoid Relay Driver Circuit (Low Side)	Voltage Above Normal, Or Shorted To High Source	520273	3
	Voltage Below Normal, Or Shorted To Low Source		4
	Current Below Normal Or Open Circuit		5
Accelerator Position/Brake Position Interaction	Condition Exists	520275	31
Throttle Position Sensor (1 or 2 Indeterminable)	Data Erratic, Intermittent Or Incorrect	520276	2
	Bad Intelligent Device Or Component		12
Throttle Body Control - Power Stage	Data Erratic, Intermittent Or Incorrect	520277	2
	Voltage Above Normal, Or Shorted To High Source		3
	Voltage Below Normal, Or Shorted To Low Source		4
	Abnormal Frequency Or Pulse Width Or Period		8

TROUBLESHOOTING

DIAGNOSTIC CODES			
COMPONENT	CONDITION	SPN	FMI
	Condition Exists		31
Throttle Body Control - Return Spring Check Failed	Condition Exists	520278	31
Throttle Body Control - Adaption Aborted	Condition Exists	520279	31
Throttle Body Control - Limp Home Position Check Failed	Condition Exists	520280	31
Throttle Body Control - Mechanical Stop Adaptation Failure	Condition Exists	520281	31
Throttle Body Control - Repeated Adaptation Failed	Condition Exists	520282	31
Throttle Body Control	Data Erratic, Intermittent Or Incorrect	520283	2
	Voltage Above Normal, Or Shorted To High Source		3
	Voltage Below Normal, Or Shorted To Low Source		4
Throttle Body Control - Position Deviation Fault	Condition Exists	520284	31
Brake Switch (1 or 2 Indeterminable)	Data Erratic, Intermittent Or Incorrect	520285	2
ECU Monitoring Error	Condition Exists	520286	31
ECU Monitoring Error (Level 3)	Condition Exists	520287	31
ECU Monitoring of Injection Cut Off (Level 1)	Condition Exists	520288	31
ECU Monitoring of Injection Cut Off (Level 2)	Condition Exists	520289	31

TROUBLESHOOTING

DIAGNOSTIC CODES			
COMPONENT	CONDITION	SPN	FMI
Throttle Body Control - Requested Throttle Angle Not Plausible	Condition Exists	520305	31
ECU ADC Fault - No Load	Condition Exists	520306	31
ECU ADC Fault - Voltage	Condition Exists	520307	31
Accelerator Sensor Sync Fault - Sensor Diff Exceeds Limit	Condition Exists	520308	31
ECU Fault - ICO	Condition Exists	520309	31
ECU Fault - Hardware Disruption	Condition Exists	520311	31
Idle Fuel Correction Bank 1	Data Valid But Above Normal Operating Range - Least Severe Level	520342	15
Idle Fuel Correction Bank 2	Data Valid But Above Normal Operating Range - Least Severe Level	520343	15
	Data Valid But Below Normal Operating Range - Least Severe Level		17
Adaptive Fuel Correction Bank 1	Data Valid But Above Normal Operating Range - Least Severe Level	520344	15
	Data Valid But Below Normal Operating Range - Least Severe Level		17
Internal fault - Chassis Output Disabled	Condition Exists	520376	31
Non Functional Application SW Installed	Condition Exists	520381	31
Stator	Voltage Below Normal, Or Shorted To Low Source	520498	4

TROUBLESHOOTING

DIAGNOSTIC CODES			
COMPONENT	CONDITION	SPN	FMI
	Current Below Normal Or Open Circuit		5
Display Relay	Current Below Normal Or Open Circuit	520522	5
Drive Mode Select Switch	Data Erratic, Intermittent Or Incorrect	524067	2
	Voltage Above Normal, Or Shorted To High Source		3
	Voltage Below Normal, Or Shorted To Low Source		4
EPS Fault Lamp Driver Circuit	Bad Intelligent Device Or Component	524085	12
EPS SEPIC Voltage Error	Voltage Above Normal, Or Shorted To High Source	524086	3
	Voltage Below Normal, Or Shorted To Low Source		4

WARRANTY

LIMITED WARRANTY

EGIMOTORS gives a TWO YEAR LIMITED WARRANTY on all components of your Tractor against defects in material or workmanship, further warrants that the spark arrester in this product will meet the efficiency requirements of USFS standard 5100-1C for at least 1000 hours when subjected to normal use and when maintenance and installation are in accordance with recommendations.

This warranty covers parts and labor charges for repair or replacement of defective parts and begins on the date of purchase by the original retail purchaser. This warranty is transferable to another owner during the warranty period through a dealer, but any such transfer will not extend the original term of the warranty. The duration of this warranty may vary by international region based upon local laws and regulations.

REGISTRATION

At the time of sale, the Warranty Registration Form must be completed by your dealer and submitted to within ten days of purchase. Upon receipt of this registration, Egimotors will record the registration for warranty. No verification of registration will be sent to the purchaser as the copy of the Warranty Registration Form will be your proof of warranty coverage. If you have not signed the original registration and received the customer copy, please contact your dealer immediately. **NO WARRANTY COVERAGE WILL BE ALLOWED UNLESS YOUR TRACTOR IS REGISTERED .**

Initial dealer preparation and set-up of your Tractor is very important in ensuring trouble-free operation. Purchasing a machine in the crate or without proper dealer set-up will void your warranty coverage.

WARRANTY COVERAGE AND EXCLUSIONS LIMITATIONS OF WARRANTIES AND REMEDIES

This limited warranty excludes any failures that are not caused by a defect in material or workmanship. **THIS WARRANTY DOES NOT COVER CLAIMS OF DEFECTIVE DESIGN.** This warranty also does not cover acts of God, accidental damage, normal wear and tear, abuse or improper handling. This warranty also does not cover any component, or part that has been altered structurally, modified, neglected, improperly maintained or used for racing, competition or purposes other than for which it was designed.

This warranty excludes damages or failures resulting from improper lubrication; improper engine timing; improper fuel; surface imperfections caused by external stress, heat, cold or contamination; operator error or abuse; improper component alignment, tension, adjustment or altitude compensation; snow, water, dirt or other foreign substance ingestion/contamination; improper maintenance; modified components; use of aftermarket or unapproved components, accessories, or attachments; use of unapproved software or calibration; unauthorized repairs; or repairs made after the warranty period expires or by an unauthorized repair center.

This warranty excludes damages or failures caused by abuse, accident, fire, or any other cause other than a defect in materials or workmanship and provides no coverage for consumable components, general wear items, or any parts exposed to friction surfaces, stresses, environmental conditions and/or contamination for which they were not designed or not intended, including but not limited to the following items:

- Wheels and tires
 - Suspension components
 - Brake components
 - Seat components
 - Clutches and components
 - Steering components
 - Batteries
 - Light bulbs/Sealed beam lamps
 - Filters
 - Lubricants
 - Bushings
 - Finished and unfinished surfaces
 - Carburetor/Throttle body components
 - Engine components
 - Drive belts
 - Hydraulic components and fluids
 - Circuit breakers/Fuses
 - Electronic components
 - Spark plugs
 - Sealants
 - Coolants
 - Bearings
-

LUBRICANTS AND FLUIDS

1. Mixing oil brands or using non-recommended oil may cause engine damage. We recommend the use of Ps 4 engine oil.
2. Damage or failure resulting from the use of non-recommended lubricants or fluids is not covered by this warranty.

This warranty provides no coverage for personal loss or expense, including mileage, transportation costs, hotels, meals, shipping or handling fees, product pick-up or delivery, replacement rentals, loss of product use, loss of profits, or loss of vacation or personal time.

THE EXCLUSIVE REMEDY FOR BREACH OF THIS WARRANTY SHALL BE, AT EGIMOTORS OPTION, REPAIR OR REPLACEMENT OF ANY DEFECTIVE MATERIALS, COMPONENTS, OR PRODUCTS. THE REMEDIES SET FORTH IN THIS WARRANTY ARE THE ONLY REMEDIES AVAILABLE TO ANY PERSON FOR BREACH OF THIS WARRANTY. POLARIS SHALL HAVE NO LIABILITY TO ANY PERSON FOR INCIDENTAL, CONSEQUENTIAL OR SPECIAL DAMAGES OF ANY DESCRIPTION, WHETHER ARISING OUT OF EXPRESS OR IMPLIED WARRANTY OR ANY OTHER CONTRACT, NEGLIGENCE, OR OTHER TORT OR OTHERWISE. THIS EXCLUSION OF CONSEQUENTIAL, INCIDENTAL, AND SPECIAL DAMAGES IS INDEPENDENT FROM AND SHALL SURVIVE ANY FINDING THAT THE EXCLUSIVE REMEDY FAILED OF ITS ESSENTIAL PURPOSE.

THE IMPLIED WARRANTY OF FITNESS FOR A PARTICULAR PURPOSE IS EXCLUDED FROM THIS LIMITED WARRANTY. ALL OTHER IMPLIED WARRANTIES (INCLUDING BUT NOT LIMITED TO THE IMPLIED WARRANTY OF MERCHANTABILITY) ARE LIMITED IN DURATION TO THE ABOVE TWO YEAR WARRANTY PERIOD. EGIMOTORS DISCLAIMS ALL EXPRESS WARRANTIES NOT STATED IN THIS WARRANTY. SOME COUNTRIES DO NOT PERMIT THE EXCLUSION OR LIMITATION OF INCIDENTAL OR CONSEQUENTIAL DAMAGES OR ALLOW LIMITATIONS ON THE DURATION OF IMPLIED WARRANTIES, SO THE ABOVE LIMITATIONS MAY NOT APPLY TO YOU IF INCONSISTENT WITH CONTROLLING APPLICABLE LAW.

HOW TO OBTAIN WARRANTY SERVICE

If your Tractor requires warranty service, you must take it to a Servicing Dealer. When requesting warranty service you must present your copy of the Warranty Registration Form to the dealer. (THE COST OF TRANSPORTATION TO AND FROM THE DEALER IS YOUR RESPONSIBILITY.)

We suggest that you use your original selling dealer; however, you may use any Servicing Dealer to perform warranty service.

IN THE COUNTRY WHERE YOUR PRODUCT WAS PURCHASED:

Warranty or Service Bulletin repairs must be done by an authorized dealer, or other qualified person. If you move or are traveling within the country where your product was purchased, Warranty and Service Bulletin repairs may be requested from any authorized dealer, or other qualified person, that sells the same line as your product.

OUTSIDE THE COUNTRY WHERE YOUR PRODUCT WAS PURCHASED:

If you are traveling temporarily outside the country where your product was purchased, you should take your product to an authorized dealer, or other qualified person. You must show the dealer photo identification from the country of the selling dealer's authorized location as proof of residence. Upon residence verification, the servicing dealer will be authorized to perform the warranty repair.

IF YOU MOVE:

If you move to another country, be sure to contact Customer Assistance and the customs department of the destination country before you move. Product importation rules vary considerably from country to country. You may be required to present documentation of your move in order to continue your warranty coverage. You may also be required to obtain documentation from your dealer in order to register your product in your new country. You should warranty register your product at a local dealer in your new country immediately after you move to continue your warranty coverage and to ensure that you receive information and notices regarding your product.

IF YOU PURCHASE FROM A PRIVATE PARTY:

If you purchase from a private party, to be kept and used outside of the country in which the product was originally purchased, all warranty coverage will be denied. You must nonetheless register your product under your name and address with a local dealer in your country to ensure that you receive safety information and notices regarding your product.

EXPORTED PRODUCTS

EXCEPT WHERE SPECIFICALLY REQUIRED BY LAW, THERE IS NO WARRANTY OR SERVICE BULLETIN COVERAGE ON THIS PRODUCT IF IT IS SOLD OUTSIDE THE COUNTRY OF THE SELLING DEALER'S AUTHORIZED LOCATION. This policy does not apply to products that have received authorization for export . Dealers may not give authorization for export. You should consult an authorized dealer to determine this product's warranty or service coverage if you have any questions. This policy does not apply to products registered to government officials or military personnel on assignment outside the country of the selling dealer's authorized location. This policy does not apply to Safety Bulletins.

NOTICE

If your product is registered outside of the country where it was purchased and you have not followed the procedure set above, your product will no longer be eligible for warranty or service bulletin coverage of any kind, other than safety bulletins. Products registered to government officials or military personnel on assignment outside of the country where the product was purchased will continue to be covered by the Limited Warranty.

Please work with your dealer to resolve any warranty issues.

Should your dealer require any additional assistance, they will contact the appropriate person at EGIMOTORS .

This warranty gives you specific legal rights, and you may also have other rights which vary from state to state or in different countries. If any of the above terms are void because of applicable laws, all other warranty terms will remain in effect.

Tractor Certificate of Pre-Delivery

Year _____ Model _____

VIN _____

Engine Serial Number _____

Key Number _____ Km / Hours _____

Registration Plate Number _____

ASSEMBLY / SERVICE / INSPECTION

- - SEALED BATTERY – Apply dielectric grease to terminal bolts and install cable. Check Voltage and charge if below 12,8 Volts.
- - BATTERY VOLTAGE – Misuse and record the battery voltage after 30 minutes after charger has been removed ____ DCV
- - TIRE PRESSURE – Verify Pressure if set to Specification
- - WHEEL NUT – Torque to specification
- - HANDLEBAR CLAMPS - Torque bolts to specification
- - MASTER CYLINDER – Torque bolts to specification
- - FRONT TOE ALIGNMENT – Verify proper toe setting
- - BALL JOINT – Inspect bolts and/or cotter pin
- - STEERING POST – Inspect cotter pin
- - TIE ROD – Inspect jam nuts and cotter pin
- - TRANSMISSION – Add oil if needed
- - GREASE FITTING – Check and Grease all the Fitting if needed
- - ENGINE OIL – Check level of oil, add if needed
- - BRAKE FLUID – Check level of fluid, add if needed in brake master cylinder(s)
- - ENGINE COOLANT – Inspect coolant in recovery bottle. Add if needed.
- - PARK BRAKE – Verify proper operation
- - INTAKE AIRBOX – Inspect hose connection and clamps. Inspect filter condition.
- - LIGHTS – Verify operation of all lights
- - FUEL – Check level of fuel and add if needed
- - WIRE HARNESS / HOSE/ LINES – Inspect wire, hoses, and line from kinks, pinching and sign of abrasion.
- - UNIT INQUIRY – Check in the system and complete applicable Service Bulletins Recalls or factory direct modification(s)
- - COSMETIC INSPECTION – Inspect the quadricycle for damage and proper fit and finish.

DEALERSHIP NAME _____ # _____

ASSEMBLED BY _____

DATE _____ / _____ / _____

SIGNATURE

STAMP

Tractor Certificate of Pre-Delivery

Year _____ Model _____

VIN _____

Engine Serial Number _____

Key Number _____ Km / Hours _____

Registration Plate Number _____

TEST RIDE

- - ENGINE – Starting acceleration and smoothness.
- - IDLE SPEED – Verify when cold and hot the engine idle properly.
- - TROTTLER – With engine idling and transmission in Neutral, swing the handlebar through entire travel range and verify proper and smooth operation.
- - ETC - Verify proper operation and throttle free play.
- - AUXILIARY SHUT OFF SWITCH - Verify proper operation.
- - BRAKES - Verify proper operation. Torque bolts to specification
- - DRIVELINE – Verify smooth operation
- - CLUTCH / TRANSMISSION – Verify proper shifting and transmission engagement/ indicator lights must correspond with gears.
- - AWD ADC – Verify proper operation.
- - REVERSE SPEED LIMITER – Verify operation and override control.
- - INSTRUMENTATION – Verify operational reading.
- - WHINCH (If equipped) – Verify proper operation.
- - SUSPENSION / STEERING – Verify adjustment, stability and operation.
- - ENGINE COOLANT Inspect coolant in recovery bottle between Min and Max after test ride, add if necessary.
- - DIAGNOSTIC SYSTEM – Run Engine up to full operating temperature. Use digital Wrench to generate and submit a "Service Report" recommended Process.
- - LEAKAGE – After completing "Diagnostic System "check for leakage and verify proper connection of oil / exhaust / fuel / Coolant / Brake fluid fitting, inspect hoses for sign and abrasion.
- - CLEAN – Wash and clean the quadricycle before delivery.

TEST RIDDEN BY

DATE _____ / _____ / _____

SIGNATURE

STAMP

Tractor Certificate of Pre-Delivery

Year _____ Model _____

VIN _____

Engine Serial Number _____

Key Number _____ Km / Hours _____

Registration Plate Number _____

DELIVERY TO CUSTOMER

- - WARRANTY REGISTRATION FORM – Completed and signed.
- - OWNERS MANUAL – Emphasize the importance of reading for customer Safety and Servicing of Quadricycle/ Explain periodic maintenance responsibilities.
- - WARRANTY POLICY – Explanation / Limit / Requirements.
- - KEYS - Record Key Number.
- - Controls – Show location and function.
- - BELT LIFE – Discuss proper operation procedure operating and proper use of High and Low Gear Range.
- - BREAK IN PROCEDURE – Review as outline in Owner's Manual.
- - STORAGE / FUELING / TRANSPORTATION – Review as outline in the owner's manual.
- - TOOL KIT – Show location.
- - Safety Video – Review with Customer.
- - SAFETY FEATURES – Review all safety features of quadricycle operation for new operation.
- - DRIVING PROCEDURE – Review Operator driving procedure outlined in the Owner's Manual.
- - SVIA TRAINING FACT SHEET – Review with customer.
- - SAFETY TRAINING COURSE SVIA – I have instructed the owner on the authorized SVIA Safety training online course.
- - PRE-DELIVERY CERTIFICATION – I certify that pre-delivery inspection and service have been performed on this vehicle in accordance with the instructions issued by Egmotors.

DEALERSHIP NAME _____ # _____

DELIVERED BY _____

DATE _____ / _____ / _____

SIGNATURE

STAMP

Tractor Certificate of Pre-Delivery

Year _____ Model _____

VIN _____

Engine Serial Number _____

Key Number _____ Km / Hours _____

Registration Plate Number _____

CUSTOMER ACCEPTANCE

- - I have reviewed the Egimotors warranty Policy / Policies
 - - I have inspected the Quadricycle and it meets my satisfaction.
 - - I understand the importance of following the Owner's Manual and instructions.
 - - I understand the importance of using all safety features.
- Review with customer.
- - I understand the importance of all operation following the operator driving procedures in the Owner's Manual.
 - - I have been instructed on the authorized online SVIA training course by my Dealer _____

(Name of dealership and person who inform the Customer)

CUSTOMER NAME _____

CUSTOMER SIGNATURE

DATE _____ / _____ / _____

Egimotors

Via Filippo da Desio 49/51
20832 Desio (MB) ITALY
info@polarisitalia.com

For more informations
visit www.Egimotors.it

