

Egimotors

2025 Owner's Manual

RZR PRO XP 2P/4P Tractor

Owner's manual part Number OM25TRZRPROXP

Read this manual carefully. It contains important safety information. This is an adult Tractor only.
Operation is prohibited for those under 18 years of age.

 **WARNING**

This Owner Manual refers to EGIMOTORS TRACTORS
(To be filled in by your Dealer)

This Owner's Manual must always remain inside you Tractor
(Legal requirement)
A digital/printable copy is available on www.egimotors.com

Year _____

Model Type _____

Code number (spare parts use only) _____

VIN Number _____

Engine Serial Number _____

Key Number _____

Registration Plate Number _____

Thank you for purchasing an EGIMOTORS Tractor, and welcome to our world-wide family of enthusiasts.

We have done This manual to inform you on how to use and maintain the best condition of operation for your Tractor.

If after reading this manual, you still have some questions please do not hesitate to contact your dealer that will be available to help you.

Be sure to visit us online at www.Egimotors.it for the latest news and for product and Safety information.

We believe we sets a standard of excellence for all utility and Tractor manufactured in the world today.

Many years of experience have gone into the engineering, design, and development of your Tractor, making it the finest machine we've ever produced.

For safe and enjoyable operation of your Tractor, be sure to follow the instructions and recommendations in this owner's manual.

Your manual contains instructions for the maintenance of the Tractor and information about repairs.

Service Manual are available from Dealers, only them can perform major repair and install accessory.

Your dealer knows your Tractor better than anyone and is interested in your total satisfaction, he can perform your service needs during and after the warranty period.

For the most up-to-date owner's manual visit:

<http://egimotors.it/libretto-uso-manutenzione/>

INTRODUCTION

Read and understand this Owner's Manual is extremely important for your safety and for all the operators, so please take your time to read all the pages and be sure that is someone else will use the Tractor before will take this manual and read and understand all, this will give you the best knowledge and skills on how to ride in security.

Copyright 2025 EGIMOTORS.

All the information contained within this publication is based on the latest product information at the time of publication.

Due to constant improvement in the design and quality of product components, some minor discrepancies may result between the actual unit and the information presented in this publication.

Descriptions and or procedure in this publication are intended for reference use only. No Liability can be accepted for omission or inaccuracies. Any reprinting or reuse of the depictions and or procedures contained within this publication are intended for reference use only. The original instruction is in English.

Other languages are provided as translation of the original Instruction see the EGIMOTORS website for more details and procedure.

INTRODUCTION	6
CERTIFICATE OF PRE-DELIVERY	9
SAFETY	13
FEATURES AND CONTROLS	35
7" DISPLAY BY RIDE COMMAND (IF EQUIPPED)	77
OPERATION	87
EMISSION CONTROL SYSTEMS	92
MAINTENANCE.....	93
SPECIFICATIONS.....	153
EGIMOTORS PRODUCTS	159
TROUBLESHOOTING.....	161
WARRANTY	183
MAINTENANCE LOG.....	188

INTRODUCTION

IMPORTANT INFORMATION

WARNING

Failure to follow the warnings contained in this manual can result in severe injury or death.

This Tractor is not a toy and can be hazardous to operate. This Tractor handles differently than other Tractors. A collision or rollover can occur quickly, even during routine maneuvers, if you fail to take proper precautions.

- Read this owner's manual. Understand all safety warnings, precautions and operating procedures before operating the Tractor. Keep this manual with the Tractor at all times.
- This Tractor is an **ADULT TRACTOR ONLY**. You **MUST** be at least 18 years of age and have a valid driver's license to operate this Tractor.
- No person under the age of 12 may ride as a passenger in this Tractor.
- Never permit a guest to operate this Tractor unless the guest has read this manual and all product labels.
- Always keep hands, feet, and all other body parts inside the Tractor at all times.
- Always wear the proper clothing when operating or riding in this Tractor. All riders should wear substantial footwear, long pants, and a close-fitting shirt. A hard hat or helmet and approved eye protection are recommended when appropriate for riding or working conditions.
- Never operate this Tractor under the influence of drugs or alcohol, as these conditions impair judgement and the operator's ability to react.

SAFETY SYMBOLS AND SIGNAL WORDS

The following signal words and symbols appear throughout this manual and on the TRACTOR. Your safety is involved when these words and symbols are used. Become familiar with their meanings before reading the manual.

DANGER

DANGER indicates a hazardous situation which, if not avoided, WILL result in death or serious injury.

WARNING

WARNING indicates a hazardous situation which, if not avoided, COULD result in death or serious injury.

CAUTION

CAUTION indicates a hazardous situation which, if not avoided, COULD result in minor to moderate injury.

NOTICE

NOTICE provides key information by clarifying instructions.

IMPORTANT

IMPORTANT provides key reminders during disassembly, assembly, and inspection of components.

The Prohibition Safety Sign indicates an action NOT to take in order to avoid a hazard.



The Mandatory Action Sign indicates an action that NEEDS to be taken to avoid a hazard.



INTRODUCTION

TOOLS FOR SAFE RIDING

To safely operate this TRACTOR, it is important to become familiar with its features, controls, and characteristics. Review the Safety Briefings for this TRACTOR that apply to you:

- Operators
- Riders
- Owners
- Trailering the TRACTOR
- Maintaining the TRACTOR

Additionally, read the product safety labels on the TRACTOR and follow all rules and regulations concerning the operation of this TRACTOR in your area.

TRACTOR IDENTIFICATION NUMBERS

Record your TRACTOR's identification number ①, engine serial number ②, and key number in the spaces provided. Remove the spare key and store it in a safe place. An ignition key can be duplicated only by ordering a EGIMOTORS key blank (using your key number) and mating it with one of your existing keys. The ignition switch must be replaced if all keys are lost.

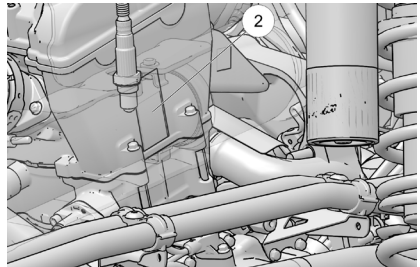
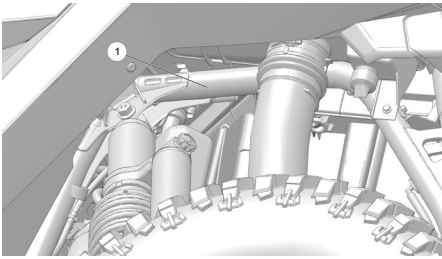

TRACTOR Model Number:	
TRACTOR Identification Number:	
Engine Serial Number:	
Key Number:	

CERTIFICATE OF PRE-DELIVERY

Tractor Certificate of Pre-Delivery

Year _____ Model _____

VIN _____

Engine Serial Number _____

Key Number _____ Km / Hours _____

Registration Plate Number _____

ASSEMBLY / SERVICE / INSPECTION

- ☒ - SEALED BATTERY – Apply dielectric grease to terminal bolts and install cable. Check Voltage and charge if below 12,8 Volts.
- ☒ - BATTERY VOLTAGE – Misuse and record the battery voltage after 30 minutes after charger has been removed _____ DCV
- ☒ - TIRE PRESSURE – Verify Pressure if set to Specification
- ☒ - WHEEL NUT – Torque to specification
- ☒ - HANDLEBAR CLAMPS - Torque bolts to specification
- ☒ - MASTER CYLINDER – Torque bolts to specification
- ☒ - FRONT TOE ALIGNMENT – Verify proper toe setting
- ☒ - BALL JOINT – Inspect bolts and/or cotter pin
- ☒ - STEERING POST – Inspect cotter pin
- ☒ - TIE ROD – Inspect jam nuts and cotter pin
- ☒ - TRANSMISSION – Add oil if needed
- ☒ - GREASE FITTING – Check and Grease all the Fitting if needed
- ☒ - ENGINE OIL – Check level of oil, add if needed
- ☒ - BRAKE FLUID – Check level of fluid, add if needed in brake master cylinder(s)
- ☒ - ENGINE COOLANT – Inspect coolant in recovery bottle. Add if needed.
- ☒ - PARK BRAKE – Verify proper operation
- ☒ - INTAKE AIRBOX – Inspect hose connection and clamps. Inspect filter condition.
- ☒ - LIGHTS – Verify operation of all lights
- ☒ - FUEL – Check level of fuel and add if needed
- ☒ - WIRE HARNESS / HOSE/ LINES – Inspect wire, hoses, and line from kinks, pinching and sign of abrasion.
- ☒ - UNIT INQUIRY – Check in the system and complete applicable Service Bulletins Recalls or factory direct modification(s)
- ☒ - COSMETIC INSPECTION – Inspect the Tractor for damage and proper fit and finish.

DEALERSHIP NAME _____ # _____

ASSEMBLED BY _____

DATE _____ / _____ / _____

SIGNATURE

STAMP

CERTIFICATE OF PRE-DELIVERY

Tractor Certificate of Pre-Delivery

Year _____ Model _____

VIN _____

Engine Serial Number _____

Key Number _____ Km / Hours _____

Registration Plate Number _____

TEST RIDE

- ENGINE – Starting acceleration and smoothness.
- IDLE SPEED – Verify when cold and hot the engine idle properly.
- TROTTLE – With engine idling and transmission in Neutral, swing the handlebar through entire travel range and verify proper and smooth operation.
- ETC - Verify proper operation and throttle free play.
- AUXILIARY SHUT OFF SWITCH - Verify proper operation.
- BRAKES - Verify proper operation. Torque bolts to specification
- DRIVELINE – Verify smooth operation
- CLUTCH / TRANSMISSION – Verify proper shifting and transmission engagement/ indicator lights must correspond with gears.
- AWD ADC – Verify proper operation.
- REVERSE SPEED LIMITER – Verify operation and override control.
- INSTRUMENTATION – Verify operational reading.
- WHINCH (If equipped) – Verify proper operation.
- SUSPENSION / STEERING – Verify adjustment, stability and operation.
- ENGINE COOLANT Inspect coolant in recovery bottle between Min and Max after test ride, add if necessary.
- DIAGNOSTIC SYSTEM – Run Engine up to full operating temperature. Use digital Wrench to generate and submit a “Service Report” recommended Process.
- LEAKAGE – After completing “Diagnostic System” check for leakage and verify proper connection of oil / exhaust / fuel / Coolant / Brake fluid fitting, inspect hoses for sign and abrasion.
- CLEAN – Wash and clean the Tractor before delivery.

TEST RIDDEN BY _____

DATE _____ / _____ / _____

SIGNATURE

STAMP

Tractor Certificate of Pre-Delivery

Year _____ Model _____

VIN _____

Engine Serial Number _____

Key Number _____ Km / Hours _____

Registration Plate Number _____

DELIVERY TO CUSTOMER

- WARRANTY REGISTRATION FORM – Completed and signed.
- OWNERS MANUAL – Emphasize the importance of reading for customer Safety and Servicing of Tractor/ Explain periodic maintenance responsibilities.
- WARRANTY POLICY – Explanation / Limit / Requirements.
- KEYS - Record Key Number.
- Controls – Show location and function.
- BELT LIFE – Discuss proper operation procedure operating and proper use of High and Low Gear Range.
- BREAK IN PROCEDURE – Review as outline in Owner's Manual.
- STORAGE / FUELING / TRANSPORTATION – Review as outline in the owner's manual.
- TOOL KIT – Show location.
- Safety Video – Review with Customer.
- SAFETY FEATURES – Review all safety features of Tractor operation for new operation.
- DRIVING PROCEDURE – Review Operator driving procedure outlined in the Owner's Manual.
- SVIA TRAINING FACT SHEET – Review with customer.
- SAFETY TRAINING COURSE SVIA – I have instructed the owner on the authorized SVIA Safety training online course.
- PRE-DELIVERY CERTIFICATION – I certify that pre-delivery inspection and service have been perform on this TRACTOR in accordance with the instructions issued by EGIMOTORS.

DEALERSHIP NAME _____ # _____

DELIVERED BY _____

DATE _____ / _____ / _____

SIGNATURE

STAMP

Tractor Certificate of Pre-Delivery

Year _____ Model _____

VIN _____

Engine Serial Number _____

Key Number _____ Km / Hours _____

Registration Plate Number _____

CUSTOMER ACCEPTANCE

 - I have reviewed the EGIMOTORS warranty Policy / Policies - I have inspected the Tractor and it meets my satisfaction. - I understand the importance of following the Owner's Manual and instructions. - I understand the importance of using all safety features.

Review with customer.

 - I understand the importance of all operation following the operator driving procedures in the Owner's Manual. - I have been instructed on the authorized online SVIA training course by my Dealer _____

(Name of dealership and person who inform the Customer)

CUSTOMER NAME _____

CUSTOMER SIGNATURE

DATE _____ / _____ / _____

SAFETY

OWNER REQUIREMENTS

Improper use, maintenance, or modification of this TRACTOR can lead to serious injury or death.

Require proper use of your TRACTOR. Do not allow anyone to operate your TRACTOR or ride as a passenger unless they are properly instructed and you are sure they are willing to ride responsibly. To prevent unauthorized use, always remove the ignition key when the TRACTOR is not in use.



Any modifications or installation of non-EGIMOTORS-approved accessories could increase the risk of injury. While you may find aftermarket products similar in design and quality to EGIMOTORS accessories, recognize that some aftermarket accessories or modifications are not suitable because of potential safety hazards to you or others. It is never appropriate to install any additional seating.

Check with the manufacturer to determine any potential effect of a modification or accessory on the safe use of your TRACTOR. You are responsible for injuries related to modifications to the TRACTOR. Modifications or accessories may:

- Damage machine components - especially modifications that increase speed or power.
- Make the TRACTOR less stable at higher speeds.
- Add weight, reducing the amount of cargo and total weight you can carry, and raise the TRACTOR's center of gravity.
- Overload the TRACTOR's electrical system capacity (see the Specifications section). Blowing a fuse may cause a loss of lights or engine power.
- Reduce the effectiveness of occupant protection systems, including the seatbelts and the Rollover Protective Structure (ROPS).
- Make it illegal to own or operate your TRACTOR. EGIMOTORS-authorized spark arrestors, mufflers, and emissions control components are mandatory for ownership or operation in many areas.
- Void your warranty.

The TRACTOR ROPS, when used with the seat belts and doors, provides a structure to help protect occupants. The structure will not protect occupants in all rollovers or accidents.

DRIVER AND PASSENGER QUALIFICATIONS

Make sure operators are 18 or older with a valid driver's license. Just because a teenager has a license does not mean that they will make good judgments about driving and avoid risk taking. This TRACTOR is not a toy and can be hazardous to operate.



EGIMOTORS recommends that you supervise younger drivers. Set rules and put limits on how, when, and where they are allowed to use this TRACTOR. For example, young drivers may need to have an adult in the TRACTOR with them and not be allowed to drive with their friends in the TRACTOR.

Make sure all riders fit the TRACTOR. Be sure that the driver and all passengers are able to:

- sit with their backs against their seat,
- adjust the seat belt to fit properly,
- have both feet flat on the floor, and
- have both hands on the steering wheel or on a passenger hand hold.

Do not allow children who need child safety seats or booster seats to ride in the TRACTOR. The TRACTOR is not designed to restrain automotive child safety seats.

You are responsible for your passengers. Be sure passengers are seated properly, belted, holding the passenger hand hold, and ready to brace. Unrestrained riders can fall out or be thrown around and from a moving TRACTOR.

Every person must be properly seated and belted in their own seat. Two people should never be belted into a single seat belt. People belted together can crash into one another in a collision and be seriously injured. Never carry passengers in the cargo bed as they could be thrown against or out of the TRACTOR or come into contact with moving parts.

Do not let people drive or ride after using alcohol or drugs.

PREPARE TRACTOR FOR THE RIDE

Before starting off, always perform the Pre-Ride Inspection. Failure to inspect and verify that the TRACTOR is in safe operating condition increases the risk of an accident, which can lead to serious injury or death.



ITEM	REMARK
Radiator	Inspect; Clean external surfaces.
Brake Fluid	Ensure proper level and condition
Front and rear suspension	Inspect, lubricate if necessary
Steering	Ensure free operation
Tires	Inspect condition and pressure
Wheels/Lug Nuts	Inspect, ensure fastener tightness
Fuel and oil	Ensure proper levels and condition
Coolant	Ensure proper level and condition
Indicator lights/switches	Ensure proper operation
Air Filter	Inspect, replace as needed
Engine intake pre-filter	Inspect, clean
PVT intake pre-filter	Inspect, clean
Headlights	Check operation
Brake lights/taillights	Check operation

SAFETY

ITEM	REMARK
Seat Latches	Push down on both seat backs to ensure the latches are secure
Seat Belts	Check length of belt for damage, check latches for proper operation
Exhaust	Inspect spark arrestor and clean if needed.
TRACTOR Debris	Remove grass, leaves, and other flammable material or debris, especially near the exhaust system.
Passenger Hand Holds	Always adjust the hand hold (where applicable) to a comfortable position for your passenger before operating. Make sure the clasps are fully locked after making adjustments.
Lock adjustable steering wheel	Do not adjust the steering wheel while the TRACTOR is moving.

Improper tire maintenance can lead to loss of control and an accident, which could result in serious injury or death. To reduce your risk of injury:

- Maintain EGIMOTORS recommended tire pressure. Check pressure before operating. Even if your TRACTOR has only been driven a short distance, the tire pressure readings can become higher.
- Make sure tire pressures match the specifications listed in the table below.
- Only use the size and type of tires specified for this TRACTOR.
- Do not operate your TRACTOR with worn or damaged tires.
- Always follow your tire manufacturer's instructions for maintenance.

MEASUREMENT	SPECIFICATION	
Model	RZR Pro XP	RZR Pro XP 4
Maximum Cargo Box Load	136 kg	136 kg
Tire Pressure in PSI (kPa)	Front: 10 PSI (69 kPa) Rear: 20 PSI (138 kPa)	Front: 14 PSI (97 kPa) Rear: 24 PSI (165 kPa)
Maximum Weight Capacity Includes weight of operator, passenger, cargo, and accessories	336 kg	408 kg

PREPARE YOURSELF, PASSENGERS, AND CARGO FOR THE RIDE

Wear an approved helmet. Riding in this TRACTOR without wearing an approved helmet increases the risk of serious injury. For example, a helmet reduces your risk of injury from head strikes with the TRACTOR or other objects even if there is no crash.

Approved helmets in Europe bear the ECE22.05 (or newer) label. The ECE mark consists of a circle surrounding the letter E, followed by the distinguishing number of the country which has granted approval. The approval number and serial number will also be displayed on the label.



Use shatterproof goggles or a shatterproof helmet face shield. Such protective eyewear may reduce the risk of foreign material getting in your eyes and help prevent loss of vision.

EGIMOTORS recommends wearing approved Personal Protective Equipment (PPE) that have markings indicating they are designed to standards CE.



Additional protective clothing and gear that may be appropriate for your riding conditions includes:

- Always wear shoes when operating. Consider wearing sturdy over-the-ankle boots suitable for the terrain you will be riding in.
- Full-finger gloves can protect against wind, sun, cold, and objects. Choose gloves that fit snugly and allow fingers to move freely and grip on the steering wheel or hand holds.
- Consider long sleeves and long pants to help protect arms and legs.
- Long-term exposure to wind and engine noise can cause permanent hearing loss. Properly worn hearing protective devices such as earplugs can help prevent hearing loss. Check local laws or the rules of the riding area you are in before wearing hearing protection to make sure its use is permitted.

Always stay completely inside the TRACTOR and hold the steering wheel or hand holds. Body parts outside of the TRACTOR can be struck by passing objects or crushed during a rollover. Do not put any part of your body outside of the TRACTOR for any reason. Do not hold onto the ROPS frame or put any part of your body on the door.

Riding in this TRACTOR without closed and latched cab doors increases the risk of serious injury or death in the event of an accident or rollover. Always make sure all cab doors are closed and latched while riding in this TRACTOR.

Be sure riders pay attention and plan ahead. If you think or feel the TRACTOR may tip or roll, reduce your risk of injury:

- Keep a firm grip on the steering wheel or hand holds and brace yourself.
- Do not put any part of your body outside of the TRACTOR for any reason.

This TRACTOR is not designed to carry unrestrained pets. An unrestrained pet can be thrown about and injure riders, even during normal operation. When transporting pets, use a pet crate suitable for off-road use that is secured to the TRACTOR.

Fuels such as gasoline can be extremely flammable. To reduce the risk of serious injury or death, never carry fuel or other flammable liquids on this Tractor. Rollovers, crashes, rough riding, or changes in elevation or temperature may lead to fuel spilling or vapor release from portable containers. Hot Tractor parts can cause fires, even after the engine has been turned off.

Never exceed TRACTOR weight capacities. Overloading the TRACTOR or carrying cargo improperly will cause changes in stability and handling, which could cause loss of control or an accident. See the Specifications chapter for weight capacities.

Secure cargo in the cargo box as far forward, centered and as low as possible. When cargo cannot be positioned and secured in this way, operate with extra caution. Unsecured cargo can strike and injure riders, affect TRACTOR handling, and result in loss of control.

The weight of riders and cargo changes TRACTOR braking, handling, and stability. To avoid loss of control, turn gradually, operate at slower speeds, and avoid rougher or steeper terrain.

DRIVING GUIDELINES

Drive Responsibly. This TRACTOR has higher ground clearance and other features to handle rugged terrain. It can be overturned in situations where some other TRACTORS may not. Abrupt maneuvers or aggressive driving, even on flat, open areas, can cause loss of control, rollovers, severe injury or death. To avoid loss of control and rollovers:



- Avoid abrupt maneuvers, sideways sliding, skidding, or fishtailing, and never do donuts.
- Slow down before entering turn.
- Avoid hard acceleration when turning, even from a stop.

High speed off-road operation

Driving off-road TRACTORS to test the limits of your skills or abilities can be very dangerous to you, passengers, and bystanders. Basic skills for driving a car, TRACTOR, or other off-road TRACTORS do not equip drivers to safely attempt high speed off-road operation. Develop your skill gradually through training, practice, and experience with the various driving modes of this TRACTOR and the terrain in which you are operating. Always do a low speed reconnaissance run (prerun) to become aware of anything you may encounter.

High speed off-road operation can lead to loss of control, crashes, or hard landings that can seriously injure occupants (even without rolling the TRACTOR or damaging it).

If you plan on using the TRACTOR for high speed, off-road competition, additional safety equipment may be necessary. Check the rules that apply to your competition.

Do not go over jumps — going airborne can lead to serious injury or death.

Going airborne can cause loss of control, rollovers, or crashing into the ground and may damage the TRACTOR. Even without crashing, landings can be hard enough to cause any TRACTOR suspension to fully compress (e.g., bottom out).

Serious injuries, including spinal injuries, can occur even if riders are properly harnessed, wearing helmets and the TRACTOR is not damaged and remains upright.

You may encounter slopes, "jumps", or other terrain features that could send the TRACTOR airborne, depending on your speed. These may be defectively designed, poorly maintained, or not suitable for this TRACTOR. Slow down, use extra care, and avoid going airborne. Never take this TRACTOR over jumps.

Watching someone else go over a jump or go airborne does not mean you can safely do so. EGIMOTORS cannot determine whether any jump you may encounter is appropriate for this TRACTOR. Any jump, even a small one, could be poorly maintained, designed, or not suitable for this TRACTOR and may cause serious injury or death.



Plan for hills, rough terrain, ruts, and other changes in traction and terrain.

Proceed slowly and with extra care on unfamiliar terrain. Avoid paved surfaces. Sudden changes in terrain such as holes, depressions, banks, softer or harder ground, or other irregularities may cause loss of control or rollover. Give yourself time to react to rocks, bumps, or holes that may be hard to see. Operating in deep snow or tall grass may make it harder to see obstacles.

If you cannot go around an obstacle, such as a fallen tree or a ditch, stop the TRACTOR in a safe place. Get out to inspect the area thoroughly. Look from both your approach side and exit side. If you are reasonably confident you can continue safely, choose the path that will allow you to go straight over the obstacle to minimize the TRACTOR tipping sideways. Go only fast enough to maintain your momentum, but still give yourself plenty of time to react to changes in conditions. If there is any question about your ability to maneuver safely over the obstacle, you should turn around if the ground is flat and you have the room, or back up until you find a less difficult path.

Abrupt application of the accelerator pedal can cause the tires to lose traction, reducing control of the TRACTOR and increasing the possibility of an accident, especially while on sloped terrain or while crossing obstacles such as rocks or logs.

This Tractor is approved for on-road use, limited to local road and NOT HIGHWAYS

SAFETY

Visibility in Rain and Snow

Weather, such as rain and snow, can reduce your visibility. Your TRACTOR may not come equipped with powered wipers, windshield, or other enclosure accessories.

Driving at Night

At night, forward visibility is reduced. Factory headlights may not provide sufficient illumination for on-road use at night, especially at higher speeds. However, be aware that aftermarket forward lights may be too bright for on-road TRACTOR traffic and using them on-road may be illegal. Weather and nighttime operation can also make it difficult for other TRACTOR traffic to see your off-road TRACTOR. Before entering a roadway after off-road operation, make sure your lights are cleaned off.

Tire Wear and Handling

Off-road tires are designed for off-road use. Using them on-road may impact handling and tire wear, particularly in rainy or snowy conditions. Refer to tire manufacturer's instructions or limitations for on-road operation, including speed limits and premature tire wear.

Roadway Debris and Gravel

Roadway debris and gravel (especially on unpaved roads) can be kicked up by other traffic (including other Tractors) on public roads and strike occupants.

Driveline Mode

Your TRACTOR may be equipped with a driveline mode selection switch. The selection of different driveline modes may affect TRACTOR handling on paved surfaces. Locking differentials and AWD are intended for off-road conditions. If equipped, operate with differentials unlocked and do not use AWD mode unless additional traction is needed due to low traction conditions. Refer to the Driveline Mode Switch section for further information.

Improperly operating on hills can cause loss of control, rollover, or accident, which can lead to serious injury or death. Use extra care when operating on hills. Plan for rough terrain, ruts, and other changes in traction and terrain.

Driving up hills

Check the terrain before ascending a hill and make sure it is not too slippery or loose. Engage all-wheel drive for hills. Drive straight uphill, keeping speed and throttle steady. Avoid steep hills which can cause the TRACTOR to overturn.

Recovering from stalling on a hill

If the TRACTOR loses forward speed, apply the brakes gradually and stop. Do not attempt to turn the TRACTOR around. Instead, shift to reverse and allow the TRACTOR to slowly roll straight downhill. Apply light brake pressure to control speed.

Overtopping a hill

Slow down when you reach the crest of a hill. Never blindly go over the crest of a hill or a drop off at high speed. An obstacle, a sharp drop, or another TRACTOR or person could be on the other side of the hill.

Driving down hills

Check the terrain before descending a hill and make sure it is not too slippery or loose. Engage all-wheel drive and proceed slowly, applying the brakes lightly. Never descend a hill with the transmission in neutral or if the engine is turned off.

Avoid side hilling (riding across slopes)

If unavoidable, proceed slowly and with extra caution. Avoid obstacles and changes in terrain that could cause the TRACTOR to tip or slide. If it feels like the TRACTOR begins to tip or slide, immediately turn downhill.

Riding near wooded areas or brush

Use extra caution when operating near trees, particularly when operating on narrow trails. Tree branches or brush can be driven into the cab striking or stabbing occupants.



SAFETY

Riding in snow

Always keep the brake and accelerator pedals free of snow and ice. Apply the brakes frequently to prevent ice or snow accumulation on the brake pads which can reduce brake performance.

Riding on ice

Never operate the TRACTOR on a frozen body of water unless you have verified that the ice can support the weight of the TRACTOR. Severe injury or death can result if the TRACTOR falls through the ice.

Riding in water / Falling into water

Operating through deep or fast-flowing water can cause loss of traction, loss of control, overturning, or being swept away in water. You can be seriously injured or killed from entrapment and drowning. Never operate the TRACTOR in fast-flowing water or in water that exceeds the floor level of the TRACTOR. Avoid sharp drop-offs and large rocks. Choose a path that provides an entrance and exit point with gradual inclines. Wet brakes may have reduced stopping ability. After leaving water, test the brakes. Apply them lightly several times while driving slowly. The friction will help dry out the pads.

Riding on sand dunes

Use extra caution when operating on or near dunes. Be alert for changes in terrain. Never blindly go over the crest of a hill or a drop-off at high speed. An obstacle, a sharp drop, or another TRACTOR or a person could be on the other side of the hill.

Riding in low-visibility conditions

Use extra caution and drive slowly in conditions of reduced visibility such as fog, rain, and darkness.

Plan ahead to avoid the need for evasive maneuvers, such as swerving.

Hitting an obstacle — including wildlife — you are not ready for can be dangerous. Choosing to swerve instead can be even more dangerous because it can lead to loss of control, rollover, or collisions.

When operating in areas with possibility of wildlife appearing in your path, plan ahead to avoid swerving for animals if doing so could result in collisions or rollovers. Go slowly or avoid driving during seasons or times of day when animals such as deer are more likely to cross your path without warning.

Avoid Collisions With Other TRACTORS

When following another TRACTOR or operating in the same area as others, keep a safe distance to avoid collisions. Allow extra space when sight distances are limited by dust, snow, curves, hills, or other conditions. Plan ahead to avoid having to swerve or leave the trail to avoid a collision.

On trails, be prepared to make space for other TRACTORS to pass. If you need to stop on a trail, move your TRACTOR to the edge of the path to allow others to pass safely.

Correct a skid by turning the steering wheel in the direction of the skid.

Never apply the brakes during a skid.

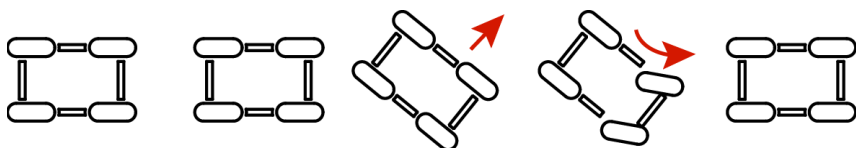

If the TRACTOR begins to slide downhill or you feel it may tip, turn downhill immediately and stop. Maneuver slowly and carefully until you can drive straight downhill.

Do not continue driving if your TRACTOR may be damaged or if you were in a crash or rollover.

Operating the TRACTOR while damaged or after a crash or rollover can cause loss of control, rollover, or accident, which can lead to serious injury or death. If you cannot safely transport the TRACTOR on your own, contact a recovery and towing service.

After any crash, rollover, or other accident, have a EGIMOTORS dealer inspect the TRACTOR for possible damage, including seat belts, ROPS, brakes, suspension, and steering systems.

Be prepared in case your TRACTOR becomes damaged or disabled, especially in remote areas. Consider in advance how to get help and stay safe until it arrives whenever you ride.

SAFETY

There is a recovery tow loop at the front and back of the TRACTOR to attach a winch or strap.

Use these loops to recover this TRACTOR if it is stuck, to pull it onto a tow truck, trailer, or to use this TRACTOR to recover another TRACTOR. These loops are for emergency recovery only and are not for towing TRACTORS to another location.

Improper recovery may lead to loss of control or TRACTOR damage. Only attach straps to specified locations. Do not attach to any other point on the TRACTOR. Only recover a TRACTOR of equal or lesser size and weight. When recovering a disabled TRACTOR, place the disabled TRACTOR's transmission in neutral. Do not move a disabled RZR faster than 10 mph (16 km/h).

Operating, Idling, Or Parking Near Combustible Materials

Engine, exhaust, and other TRACTOR components can be very hot during and after use. Do not idle or park the TRACTOR over anything that could contact the exhaust system and catch on fire, such as tall grass, weeds, brush, leaves, debris, or other tall ground cover. Do not let mud, grass, or other debris accumulate on the engine or exhaust system. Inspect and remove as needed.

TRACTOR rollaway can cause serious injury or death. Even when stationary, the TRACTOR may move whenever the gear selector is not in the PARK (P) position or when the brakes are not applied. Always shift to PARK (P) when turning off the engine or leaving the TRACTOR. Use extra care, when leaving the TRACTOR on an incline is unavoidable. If leaving the TRACTOR unattended on a hill, block the rear wheels on the downhill side and keep children, pets and others away from the gear selector.

Before shifting into reverse, use extra care to make sure the area is clear of people or obstacles. When it's safe to proceed, back slowly.

After operation, inspect the TRACTOR for damage and debris to make sure the TRACTOR can be safely stored and operated again. Some things to inspect include:

- Debris that could catch fire, such as mud/grass near the engine or exhaust system
- Damage to the suspension, steering, or any other part of the TRACTOR
- Tire condition, such as tread and sidewall damage
- Shock absorber assembly condition

Be sure to have any issues checked and problems fixed before operating again.

All engine exhaust contains carbon monoxide, a deadly gas. Breathing carbon monoxide can cause headaches, dizziness, drowsiness, nausea, confusion, and eventually death. Carbon monoxide is a colorless, odorless, tasteless gas which may be present even if you do not see or smell any engine exhaust. Deadly levels of carbon monoxide can collect rapidly, and you can quickly be overcome and unable to save yourself. Also, deadly levels of carbon monoxide can linger for hours or days in enclosed or poorly ventilated areas. If you experience any symptoms of carbon monoxide poisoning, leave the area immediately, get fresh air, and SEEK MEDICAL TREATMENT.

- Do not run engine indoors. Even if you try to ventilate engine exhaust with fans or open windows and doors, carbon monoxide can rapidly reach dangerous levels.
- Do not run engine in poorly ventilated or partially enclosed areas such as barns, garages, or carports. If you start a TRACTOR in one of these, drive it out and close the door as soon as possible. If you drive it into one of these, turn it off as soon as possible.
- Do not run engine outdoors where engine exhaust can be drawn into a building through openings such as windows and doors.

SAFETY LABELS AND LOCATIONS

OVERVIEW

Warning labels have been placed on the TRACTOR for your protection. Read and follow the instructions of the labels on the TRACTOR carefully. If any of the labels depicted in this manual differ from the labels on your TRACTOR, always read and follow the instructions of the labels on the TRACTOR

Never remove any labels from your TRACTOR. If a label becomes illegible or comes off, contact your EGIMOTORS dealer for a replacement. Replacement safety labels are provided at no charge.

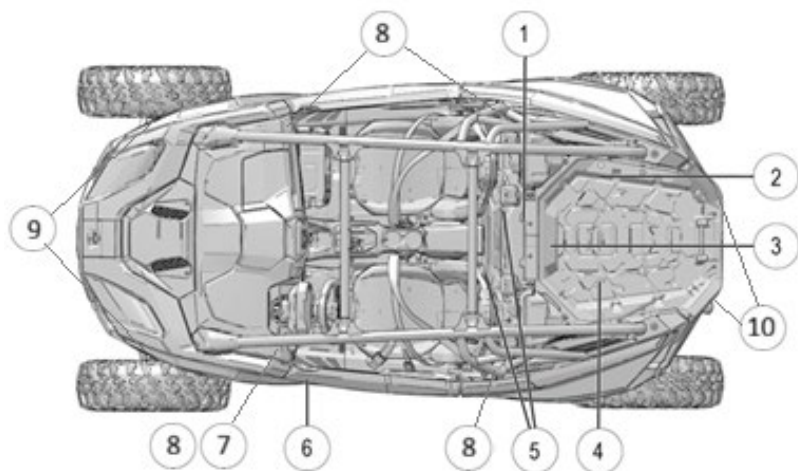

- | | |
|---|------------------------------|
| ① Air Box Caution (On Air Box) | ⑥ Driver Information Warning |
| ② Fuel Transport Warning | ⑦ Seat Warning |
| ③ Tire Pressure Warning | ⑧ Seat Belt Warning |
| ④ Belt Debris Warning (On Clutch Cover) | ⑨ Greasing Point Alert |
| ⑤ Rear Seat Warning (Pro XP 4 Only) | ⑩ Jacking Point Alert |

DRIVER INFORMATION WARNING — 2 PERSON

WARNING

FOLLOW ALL INSTRUCTIONS AND WARNINGS.

Improper TRACTOR use can result in SEVERE INJURY or DEATH.

Be Prepared

- Fasten seat belts.
- Wear an approved helmet and protective gear.
- **ALWAYS** use cab nets and/or doors.
- Each rider must be able to sit with back against seat, feet flat on the floor, and hands on steering wheel or hand holds. Stay completely inside the TRACTOR.

Drive Responsibly

Rollovers have caused severe injuries and death, even on flat, open areas.

Avoid loss of control and rollovers:

- Avoid abrupt maneuvers, sideways sliding, skidding or fishtailing, and never do donuts.
- Slow down before entering a turn.
- Avoid hard acceleration when turning, even from a stop.
- Plan for hills, rough terrain, ruts and other changes in traction and terrain.
- Avoid paved surfaces.
- Avoid side hilling (riding across slopes).

Require Proper Use of Your TRACTOR

Do your part to prevent injuries:

- Do not allow careless or reckless driving.
- Make sure operators are 18 or older with a valid driver's license.
- Do not let people drive or ride after using alcohol or drugs.
- Be aware during operation on public roads - collisions with cars and trucks can occur.
- Do not exceed seating capacity: 1 passenger.

Be Sure Riders Pay Attention and Plan Ahead

If you think or feel the TRACTOR may tip or roll, reduce your risk of injury:

- Keep a firm grip on the steering wheel or hand holds and brace yourself.
- Do not put any part of your body outside of the TRACTOR for any reason.

Part Numbers: Left 7301003, Right 7301004

SAFETY

DRIVER INFORMATION WARNING — 4 PERSON

WARNING

FOLLOW ALL INSTRUCTIONS AND WARNINGS.

Improper TRACTOR use can result in SEVERE INJURY or DEATH.

Be Prepared

- Fasten seat belts.
- Wear an approved helmet and protective gear.
- **ALWAYS** use cab nets and/or doors.
- Each rider must be able to sit with back against seat, feet flat on the floor, and hands on steering wheel or hand holds. Stay completely inside the TRACTOR.

Drive Responsibly

Rollovers have caused severe injuries and death, even on flat, open areas.

Avoid loss of control and rollovers:

- Avoid abrupt maneuvers, sideways sliding, skidding or fishtailing, and never do donuts.
- Slow down before entering a turn.
- Avoid hard acceleration when turning, even from a stop.
- Plan for hills, rough terrain, ruts and other changes in traction and terrain.
- Avoid paved surfaces.
- Avoid side hilling (riding across slopes).

Require Proper Use of Your TRACTOR

Do your part to prevent injuries:

- Do not allow careless or reckless driving.
- Make sure operators are 18 or older with a valid driver's license.
- Do not let people drive or ride after using alcohol or drugs.
- Be aware during operation on public roads - collisions with cars and trucks can occur.
- Do not exceed seating capacity: 3 passengers.

Be Sure Riders Pay Attention and Plan Ahead

If you think or feel the TRACTOR may tip or roll, reduce your risk of injury:

- Keep a firm grip on the steering wheel or hand holds and brace yourself.
- Do not put any part of your body outside of the TRACTOR for any reason.

Part Numbers: Left 7301009, Right 7301010

LOAD / PASSENGER / TIRE PRESSURE WARNING**WARNING**

The Load / Passenger / Tire Pressure Warning (1) is located at the rear of the TRACTOR in the cargo box.

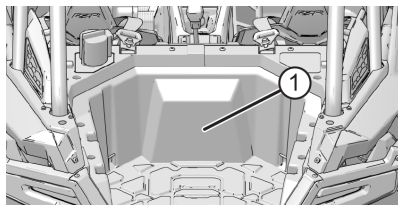

- Never carry passengers in cargo box.
- Passengers can be thrown off. This can cause serious injury or death.

IMPROPER TIRE PRESSURE OR OVERLOADING CAN CAUSE LOSS OF CONTROL RESULTING IN SERIOUS INJURY OR DEATH.

- Reduce speed and allow greater distance for braking when carrying cargo.
- Overloading or carrying tall, off-center, or unsecured loads will increase your risk of losing control. Loads should be centered and carried as low as possible in box.
- For stability on rough or hilly terrain, reduce speed and cargo.

	Pro XP	Pro XP 4
MAXIMUM CARGO BOX LOAD	136 kg	
TIRE PRESSURE IN PSI (KPa)	FRONT 10 (69) REAR 20 (138)	FRONT 14 (97) REAR 24 (165)
MAXIMUM WEIGHT CAPACITY INCLUDES WEIGHT OF OPERATOR, PASSENGERS, CARGO AND ACCESSORIES	336 kg	408 kg
Read Operation and Maintenance Manual for more detailed loading information.		

Part Number: 7300400

SAFETY

FUEL TRANSPORT WARNING

⚠ WARNING

Improperly carrying fuel can lead to serious burn injuries or death. Rollovers, crashes, rough riding, or changes in elevation or temperature may lead to fuel spills or vapor release and fire.

Never carry fuel or other flammable liquids on this vehicle

BELT DEBRIS WARNING

⚠ WARNING

The Belt Debris warning **①** is located on the clutch cover.

Improper service or maintenance of this PVT system can result in TRACTOR damage, SEVERE INJURY or DEATH.

Always look for and remove debris inside and around clutch and vent system when replacing belt.

Read owner's manual or see authorized EGIMOTORS dealer.

Part Number: 7177469

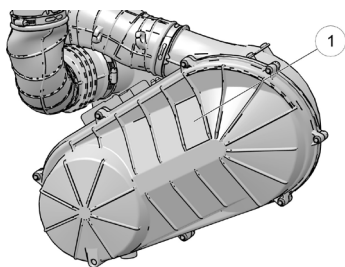

DRIVER INFORMATION WARNING

Read your owner's manual. Never allow anyone under 18 years of age to operate this TRACTOR. Never use alcohol or drugs before or while driving or riding. This TRACTOR is approved for on-road operation. Wear approved helmet, goggles, and protective clothing.

SEAT WARNING

This vehicle is equipped with seat sensor. Always wear seat belts. Always close doors before driving. Never exceed seating capacity.

AIR BOX CAUTION (7182652)

CAUTION

Use a EGIMOTORS approved air filter. The use of a non-EGIMOTORS approved air filter may cause engine damage. Before installing filter, ensure there is no dirt or debris in the clean side of the intake tube. The air filter must be properly seated before the lid is reinstalled. Please reference your owner's manual for additional information regarding air filter service.

Part Number: 7182652

REAR SEAT WARNING — PRO XP 4

WARNING

Do not ride in rear cabin area when seat back or seat base is not installed in riding position.

Part Number: 7300168

GREASING POINTS ALERT

Lubricate as recommended.
Read owner's manual.

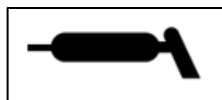

JACKING POINTS ALERT

Jacking positions are located beneath the Tractor's center points. Read the owner's manual.



FEATURES AND CONTROLS

COMPONENT LOCATIONS

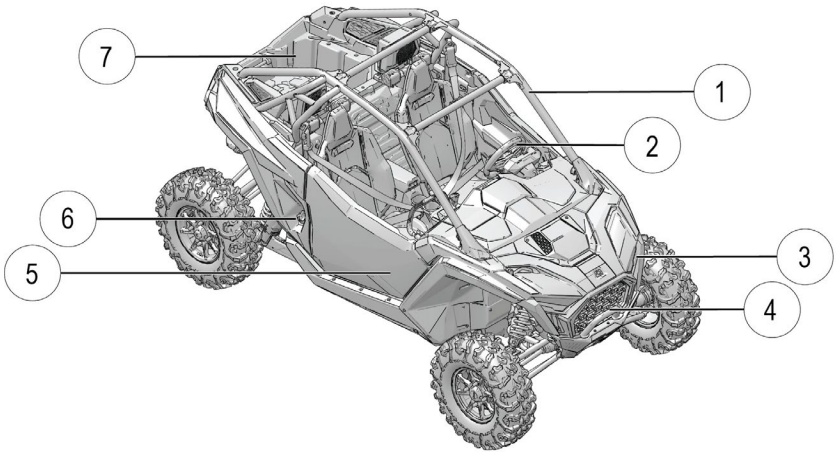

- ① ROPS Frame
- ② Steering Wheel
- ③ Headlights
- ④ Radiators
- ⑤ Cab Door
- ⑥ Fuel Tank Cap
- ⑦ Cargo Box

STANDARD STEERING WHEEL (IF EQUIPPED)

The steering wheel can be tilted upward or downward for rider preference. Lift and hold the steering wheel adjustment lever ① while moving the steering wheel upward or downward. Release the lever when the steering wheel is at the desired position.

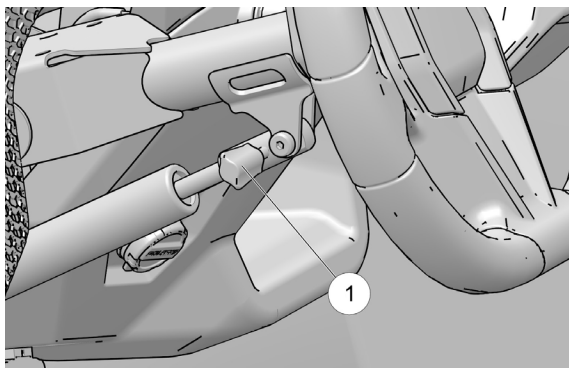

TILT / TELESCOPING STEERING WHEEL (IF EQUIPPED)

The telescoping steering wheel can be adjusted by pressing the release lever ① downward. Once released, the steering wheel can be tilted up/down and telescoped in/out freely. When desired position is found, hold the steering wheel in place with one hand and pull the release lever back up with the other. The release lever will catch into place when it is locked.

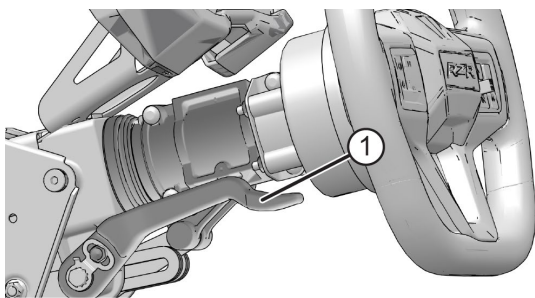

SWITCHES

IGNITION SWITCH

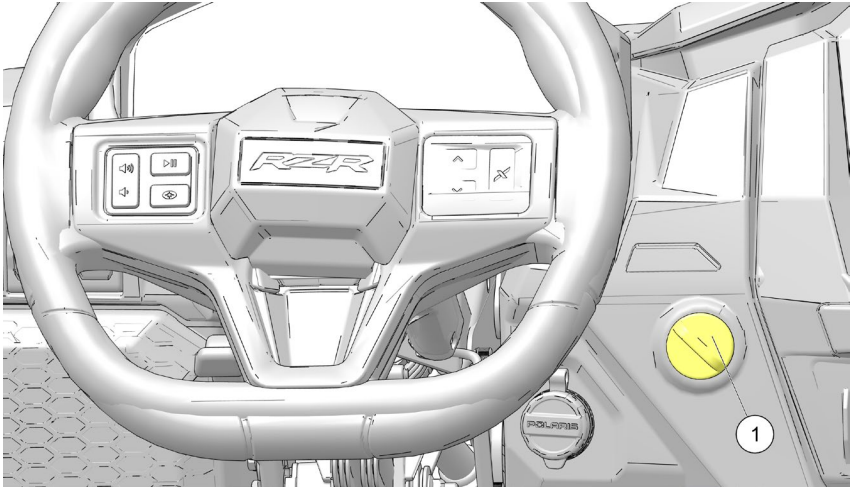

The ignition switch ① is a four-position, key-operated switch. Use the ignition switch to start the engine. See the Starting the Engine section for starting procedures.

POSITION	FUNCTION
OFF	The engine is off. Electrical circuits are off, except accessory 12V.
ACCESSORY	The engine is off. Powers the display, terminal block, and front/rear accent lights.
ON	Electrical circuits are on. Electrical equipment can be used. Check engine and power steering warning indicators will appear on the display in this mode but will turn off when the TRACTOR is started if no issues are present.
START	The TRACTOR must be in PARK or NEUTRAL before the engine can start. To start the TRACTOR, press the brake pedal, turn the key to the start position, and then release. The engine will turn over for about 5 seconds or until started.

The key can be removed from the switch when it is in the OFF position.

FEATURES AND CONTROLS

HEADLIGHT SWITCH

Move the headlight switch up to cycle between dim and high beam modes. The ignition switch key must be in the ON/RUN position to operate the headlights.



DRIVELINE MODE (AWD) SWITCH

The ignition switch key must be in the ON/RUN position to operate the Driveline Mode system. The Driveline Mode switch is a toggle and has two positions:

UP – All Wheel Drive (AWD)

CENTER – Two Wheel Drive (2WD)



HORN SWITCH

The horn switch is located on the turn signal lever (1). Press the tip of the turn signal lever inward to sound the horn.



HAZARD SWITCH

Push the hazard warning switch to cause all turn signal lights to flash simultaneously. Use this feature to alert others of an emergency or other situation requiring caution.



TURN SIGNAL

Before turning, activate a turn signal to alert others of your intentions. Check turn signal lamps before each ride.

TIP

The key must be in the ON position to activate the turn signals.

Move the turn signal lever downward (1) to signal a left turn. The left turn signal lamps in the taillight and below the front headlight will flash. The turn signal indicator in the gauge will also flash.

Move the lever upward (2) to signal a right turn. The right signal lamps and indicator will flash.

Return the lever to the center position to end the signal.

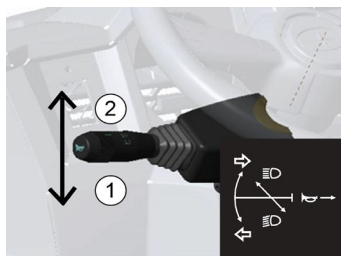

AUXILIARY OUTLETS

WARNING

To avoid electric shock, do not touch power outlets with wet hands or insert any object that the power outlet is not designed to receive. Close the lid when not in use.

NOTICE

The front console accessory outlet is always active. The accessory outlet in the armrest storage bin is only active when the ignition switch is set to ON.

The TRACTOR is equipped with two 12-volt accessory outlets. One is in the front portion of the center console, in front of the gear selector. The other is in the armrest storage bin. Use the outlets to power an auxiliary light or other optional accessories.

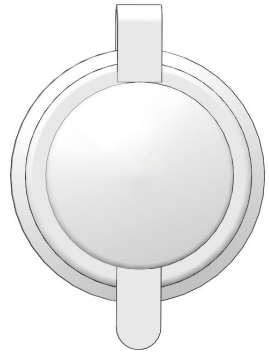

TRACTOR BATTERY CHARGE PORT

This TRACTOR is equipped with a TRACTOR battery charge port located on the dash. This allows the operator to charge the TRACTOR battery without needing to access the battery under the driver's seat. See the Battery Maintenance and Charging section for details.



FEATURES AND CONTROLS

FUEL CAP

NOTICE

Never use fuel blends with more than 10% ethanol. Engine damage could occur.

The fuel tank filler cap ① is located on the right side of the TRACTOR near the passenger seat. Use only unleaded gasoline with a minimum pump octane number of 91 octane rating $(R+M)/2$ or 95 RON minimum. Do not use fuel with ethanol content greater than 10 percent, such as E-85 fuel.

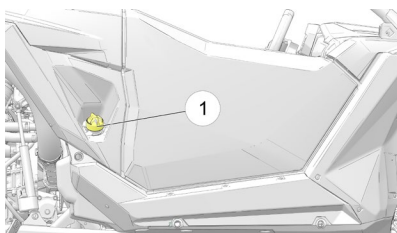

The fuel symbol and the last fuel bar on the MFD gauge will blink when the fuel level reaches 1/8th tank. There will be approximately 8 L of fuel remaining. Refuel as soon as possible. *Do not allow the TRACTOR to run out of fuel.*

NOTICE

Damage to the fuel pump can occur if the TRACTOR is operated with an empty fuel tank. Do not allow the TRACTOR to run out of fuel. Always refuel when the level is low.

NOTICE

Operating with obstructed fuel systems will result in serious engine damage. Perform maintenance as recommended.

NOTICE

Prolonged exposure to petroleum based products may damage paint. Always protect painted surfaces when handling fuel.

PORTABLE FUEL CONTAINERS

WARNING

Fuels such as gasoline can be extremely flammable. Rollovers, crashes, rough riding, or changes in elevation or temperature may lead to fuel spilling or vapor release from portable containers. Hot TRACTOR parts can cause fires, even after the engine has been turned off. Improperly carrying fuel can lead to serious burn injuries or death.

Never carry fuel or other flammable liquids on this vehicle.

ELECTRONIC POWER STEERING (EPS)

Electronic power steering engages when the ignition key is turned to the ON position. EPS remains engaged whether the TRACTOR is moving or idle.

The EPS warning indicator briefly illuminates when the key is turned to the ON position. See the Indicator Lamps section for details.

NOTE

The EPS shuts down automatically to conserve the battery power of your TRACTOR. EPS will reactivate when the steering wheel is moved.

If the EPS warning indicator remains on after turning the ignition switch to OFF and then starting the engine, the EPS system is inoperative. See your EGIMOTORS dealer, or another qualified person, as soon as possible for repair. Continued operation could result in permanent damage to the EPS unit and increased steering effort.

FEATURES AND CONTROLS

CAB DOORS

This TRACTOR has cab doors that include hand holds ① on the inside. Riding in this TRACTOR without closed and latched cab doors increases the risk of serious injury or death in the event of an accident or rollover. Always make sure all cab doors are closed and latched when riding in this TRACTOR.

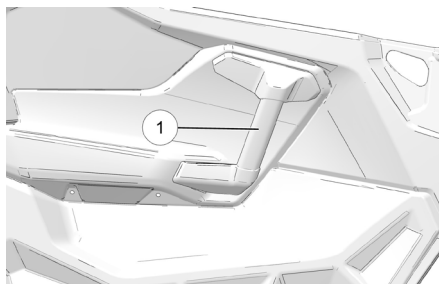

Always inspect doors and latches for wear and damage before each use of the TRACTOR.

Promptly replace any worn or damaged parts with new parts available from your authorized EGIMOTORS dealer or qualified person.

AUDIO CONTROLS (IF EQUIPPED)

Audio controls can be found on the left-hand side of the steering wheel. Volume can be adjusted by pressing the bottom (lower volume) or the top (higher volume) of the button. Audio can be paused or resumed by pressing the pause button.

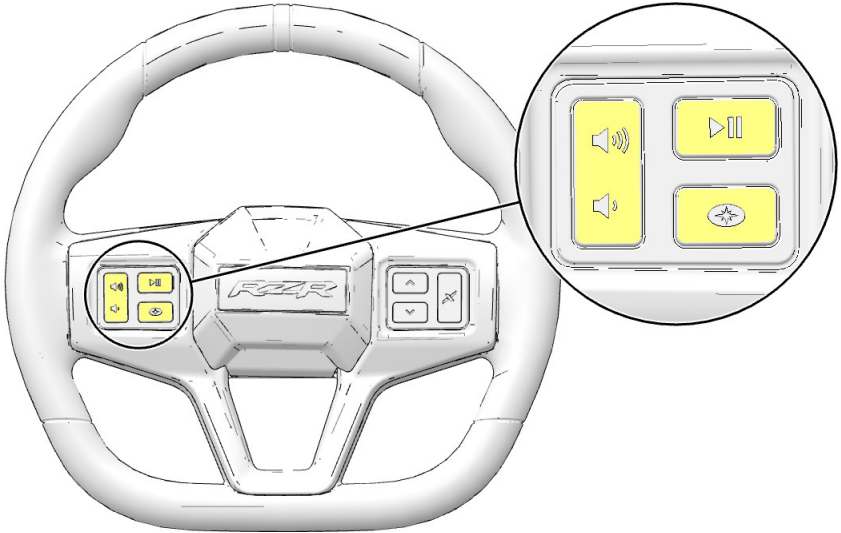

The EGIMOTORS button will switch the display between the gauge, map, and music screens.

For more information on the suspension buttons on the right-hand of the steering wheel, see the Suspension Controls section.

FEATURES AND CONTROLS

SEATS

SEAT REMOVAL

To adjust the seat, do the following:

1. Pull up on the seat latch lever ① located under the front edge of the seat.
2. Tilt the seat forward.
3. Lift the seat upward to remove it from the TRACTOR.

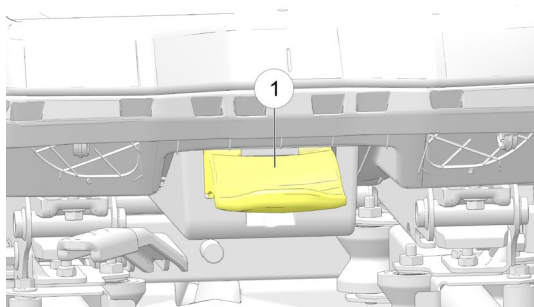

4. Reverse this procedure to reinstall the seat. Make sure the seat tabs at the front edge of the seat slide onto the seat retainer tubes.
5. Press down firmly at the rear of the seat to engage the rear latches.

REAR SEAT REMOVAL

1. Reach behind the headrest and pull on the latch ① to release the seat back.

OPTIONAL: The seat back can be removed entirely or reinstalled once seat base is flipped, depending on preference.

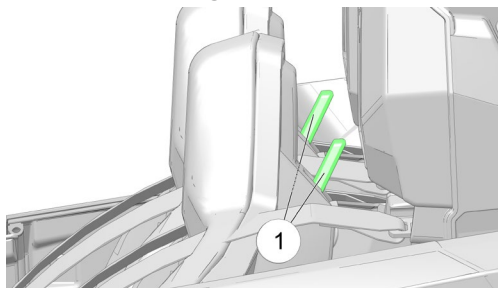

2. Once the seat back is removed, grab one of the straps ① at the rear of the seat base.

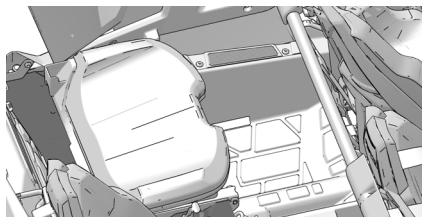

3. Use the straps to pull upward and flip the seat base completely over.



4. To reinstall the seat back, align the bottom stems (2) with their appropriate housings. Once aligned, push the seat headrest back until the latch makes an audible 'click' sound.

SEAT ADJUSTMENTS

DRIVER'S SEAT ADJUSTMENT

On seats equipped with an adjustment lever (2) under the front edge of the seat, pull the lever to the left. Slide the seat forward or rearward to the desired position. Release the lever. The seat will lock into the new position.

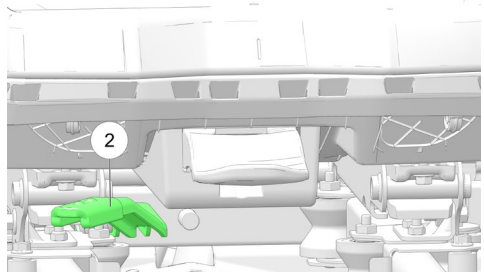

To adjust seat tilt, adjustment bolts can be removed and re-installed at a different tilt setting. The driver side has two adjustment bolts (3), one on each side, and has two tilt hole options. Re-install the bolts to specification when finished with adjustments.

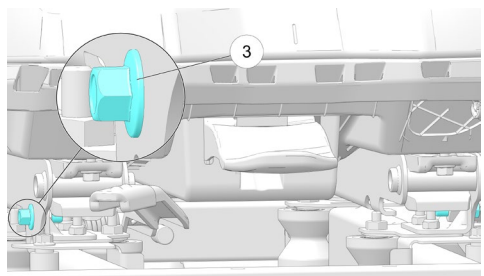

TORQUE

Seat Adjustment Bolts:
20 N·m

FEATURES AND CONTROLS

SEAT BELTS

This EGIMOTORS TRACTOR is equipped with seat belts for all riders. Always make sure the seat belts are secured for the operator and all passengers before riding.

MULTI-POINT SEAT BELT

CAUTION

Be sure to follow the procedures below exactly as described. Improperly securing the seat belt can result in free movement during operation, which can lead to injury.

The safety harness requires proper adjustment for each rider and will need to be adjusted when riders change seats.

WARNING

Improper use or adjustment of the harness can cause serious injury or death. For example, you can slide under the harness in an accident if the lap belt portion of the harness is not pressed against the pelvic bones. Always adjust the harness for each rider to make sure it fits them.

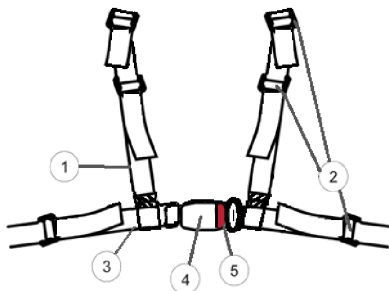

- ① Shoulder Belt
- ② Tilt-locks
- ③ Lap Belt
- ④ Harness Buckle
- ⑤ Buckle Release Button

PUTTING ON THE HARNESS

To prepare the rider:

1. Do not wear heavy clothing that may interfere with proper fit of the harness. Make sure there are no rigid or breakable items (e.g., eye glasses, pens, jewelry, keys) under the harness.
2. Before entering the Tractor, your helmet should be off, but accessible from the seat.
3. Adjust the seat to the desired position.
4. Unbuckle the harness and loosen all manually adjustable belts:
 - Lap belts
 - Thigh belts
 - Shoulder belts

How to use straps to tighten and loosen the belts:

To tighten a belt pull the ends of the belts to adjust to your body (you must adjust belt by pulling all 6 ends to fit properly).

To loosen a belt, grasp the tilt locks regulators and pull up in one hand and pull the belt with the other. Adjust the angle of the tilt-lock until the belt pulls more easily.

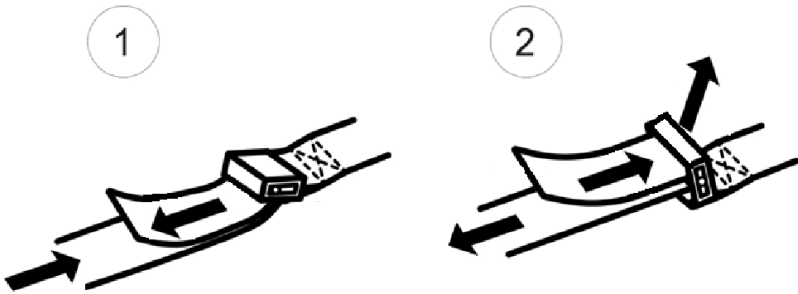

- ① To tighten - pull down belt end to adjust to your position
- ② To loosen - lift up the tilt lock to release the belt.

To adjust the harness:

1. Put your arms through the shoulder belts. The belts should lay flat and not be twisted. The shoulder belt should not rub against your neck or fall off your shoulder.

FEATURES AND CONTROLS

2. Buckle the harness and check the fit of the lap belt. It should be as short as possible and pressed against your pelvic bones so that you cannot lift yourself from the seat bottom at all. Unbuckle and tighten the lap belts as needed until the seat belt is properly adjusted – it is easier to adjust the belts while unbuckled. Finally, buckle the harness and listen for a click. Check fit and make sure buckle is secure.



3. Tighten shoulder belts. Adjust shoulder belts, tighten the shoulder belts until they are snug across your chest when your back is against the seat. When tightening the shoulder belts, be sure to keep the harness buckle centered and below your belly button. The lap belt must remain pressed against your pelvic bones.



4. Tighten thigh belts. If your harness is equipped with thigh belts, adjust them for comfort and be sure to keep the harness buckle centered and below your belly button. The lap belt must remain pressed against your pelvic bones.



5. Put on your helmet.

To take off the harness:

1. Push the red button to release the buckle.
2. Remove your arms from the shoulder belt.
3. After exiting the Tractor, buckle the harness to prevent damage which can occur if it is slammed in the door or hangs out of the Tractor.

SEAT BELT INSPECTION

Inspect all seat belts for proper operation before each use of the Tractor.

1. Push the latch plate into the buckle until it clicks. The latch plate must slide smoothly into the buckle. A click indicates that it's securely latched.
2. Push the red release latch in the middle of the buckle to make sure it releases freely.
3. Pull each seat belt completely out and inspect the full length for any damage, including cuts, wear, fraying or stiffness. If any damage is found, or if the seat belt does not operate properly, have the seat belt system checked and/or replaced by an authorized EGIMOTORS dealer or qualified person.
4. To clean dirt or debris from the seat belts, sponge the straps with mild soap and water. Do not use bleach, dye or household detergents. Rinse the entire length of the belt webbing. Use a garden hose to flush out the latch regularly.

SERVICE ACCESS PANELS

ENGINE ACCESS PANEL

The engine access panel is located behind the seats. Adjust or remove the seats, then remove the panel to reach serviceable engine components. Remove the panel by turning the close-off knobs ① 1/4 turn.

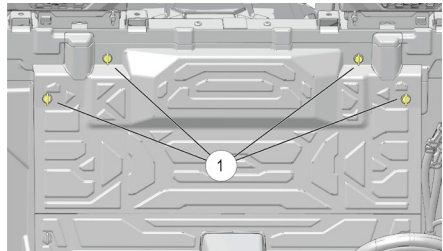

CARGO BOX ACCESS

CAUTION

The cargo box rests directly above heat-generating TRACTOR components. Be careful when removing the cargo box immediately following operation. It will likely be hot and could cause burns.

The entire cargo box layer can be lifted to access the engine oil fill cap and spark plugs by removing the four rear-most screws ②.

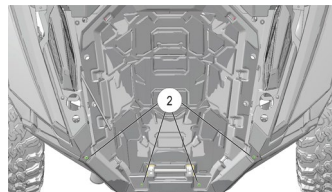

FEATURES AND CONTROLS

PASSENGER HAND HOLDS

To adjust the front passenger grab bar hand hold, do the following:

1. Unlock the two passenger hand hold clasps ①.
2. Pull or push the bar to desired position.
3. Lock both clasps back into place.

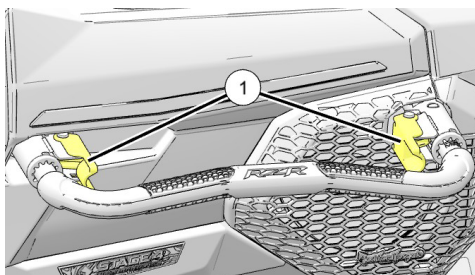

A hand hold ② is also located on the interior panel of each door and is intended for use with the hand closest to the door.

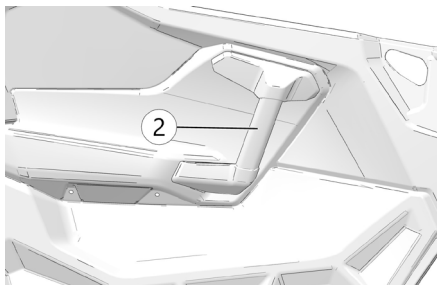

AIR VENTS

Air vents push additional airflow from the center of the hood to the cabin and are found on both the driver ① and passenger ② sides near the doors. Use the slats located on the air vents to open or close the vents.

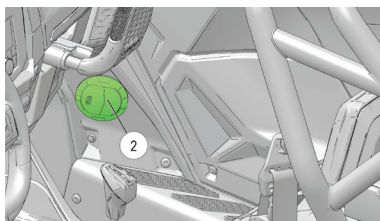
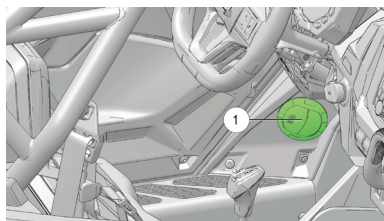

ROLLOVER PROTECTIVE STRUCTURE (ROPS)

Always have your authorized EGIMOTORS dealer thoroughly inspect the ROPS if it ever becomes damaged in any way.

NOTE

Be mindful of the ROPS bars when boarding and exiting the TRACTOR.

① ROPS Label

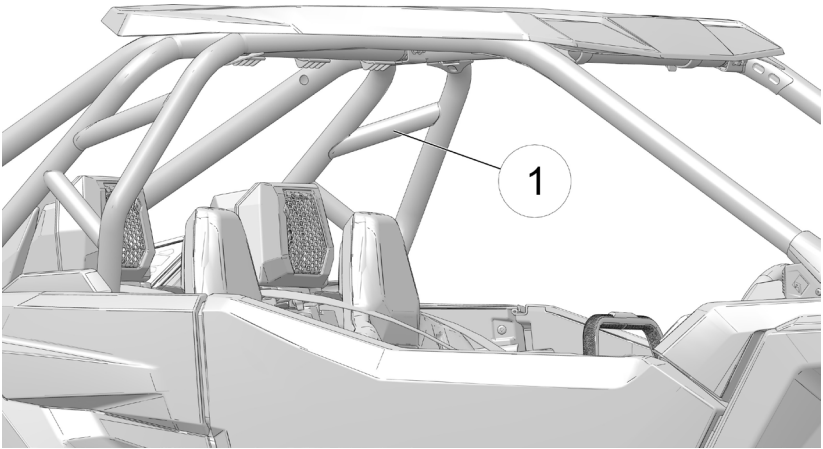

No device can assure occupant protection in the event of a rollover. When used with seat belts and cab nets or doors, the ROPS helps prevent occupants from being ejected from the TRACTOR. Always follow all safe operating practices outlined in this manual to avoid TRACTOR rollover.

WARNING

TRACTOR rollover could cause severe injury or death. Always avoid operating in a manner that could result in TRACTOR rollover.

FEATURES AND CONTROLS

GEAR SELECTOR

The gear selector is located between the driver and passenger seat ①. To change gears, stop the TRACTOR and with the engine idling, move the lever to the desired gear. Do not attempt to shift gears with engine speed above idle or while the TRACTOR is moving.

- P: Park
- R: Reverse
- N: Neutral
- L: Low Gear
- H: High Gear

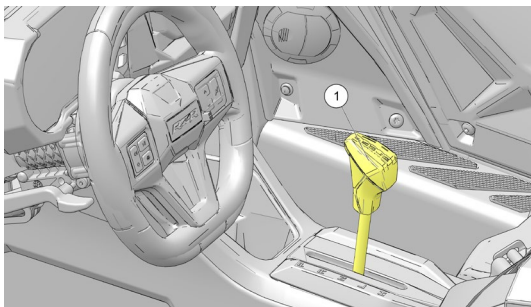

NOTICE

Maintaining shift linkage adjustment is important to assure proper transmission function. Your EGIMOTORS dealer can assist in resolving any shifting problems.

NOTICE

Do not attempt to shift the transmission while the TRACTOR is moving as damage to the transmission could result. Always shift when the TRACTOR is stationary and the engine is at idle.

USING LOW GEAR

NOTICE

Using Low Gear when conditions require it will prolong the life of your TRACTOR's drive belt.

Always shift into low gear for any of the following conditions:

- Operating in rough terrain or over obstacles
- Loading the TRACTOR onto a trailer
- When hauling or towing heavy cargo.
- When consistently operating at speeds less than 46 km/h in hard-pulling terrain, such as mud, rocks, or sand/dune environments.

BRAKE AND THROTTLE PEDALS

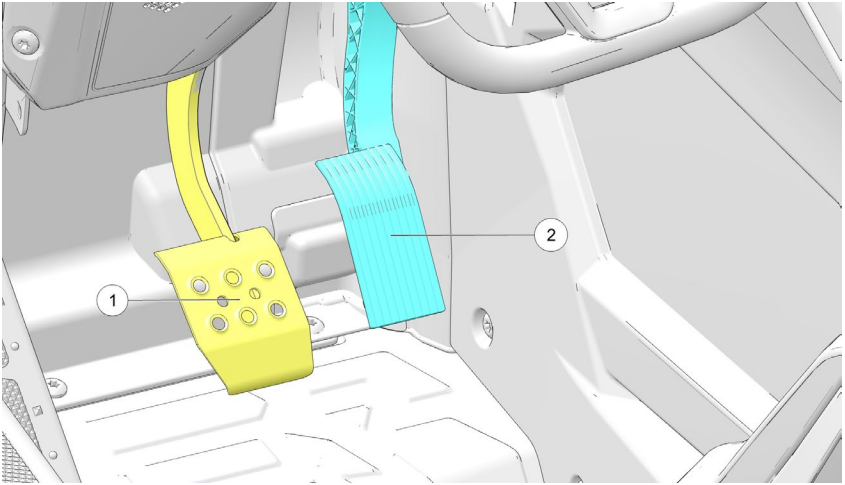

BRAKE PEDAL

Depress the brake pedal (1) to slow or stop the TRACTOR. The brakes must be applied in order to start the engine.

SECONDARY BRAKE PEDAL

Your Tractor is Equipped with a secondary pedal (3) for brake in case of failure of the standard one.

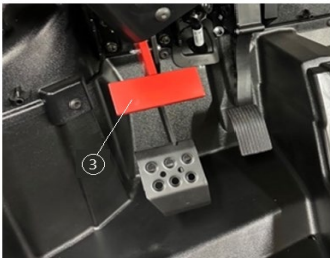

THROTTLE PEDAL

Push the throttle pedal (2) down to increase engine speed. Spring pressure returns the pedal to the rest position when released. Always check that the throttle pedal returns normally before starting the engine.



NOTICE

When traveling over 16 km/h with the throttle pedal depressed, applying the brake for more than two seconds will disable the throttle pedal until the **brake is released.**

FEATURES AND CONTROLS

ALL WHEEL DRIVE (AWD) SYSTEM

The All Wheel Drive system is controlled by the AWD switch. Once the TRACTOR is in gear, the switch is set to one of two driveline modes.

ICON	DRIVELINE MODE	DESCRIPTION
	Two-Wheel Drive (2WD)	When the switch is set to 2WD the TRACTOR is in two-wheel drive at all times.
	All Wheel Drive (AWD)	<p>When the switch is set to AWD and the TRACTOR is in Drive or Reverse, the TRACTOR is in all wheel drive and the 4X4 indicator in the instrument cluster will be on</p> <p>When in AWD, the demand drive unit will automatically engage any time the rear wheels lose traction. When the rear wheels regain traction, the demand drive unit will automatically disengage.</p> <p>There is no limit to the speed or length of time the TRACTOR may remain in AWD.</p>

ENGAGING AWD

The AWD switch may be turned on or off while the TRACTOR is moving. Initially, the TRACTOR's electronic system will not enable the AWD until the engine RPM is below 3100 and the TRACTOR speed is below 24 km/h. Once enabled, the AWD remains enabled until the AWD switch is turned off. If the switch is turned off while the demand drive unit is moving, it will not disengage until the rear wheels regain traction.

Engage the AWD switch before getting into conditions where all-wheel drive may be needed. If the rear wheels are spinning, release the throttle before switching to AWD.

NOTICE

Switching to AWD while the rear wheels are spinning or slipping may cause severe drive shaft, prop shaft, and gearcase damage. Always switch to AWD while the rear wheels have traction or are at rest.

INSTRUMENT CLUSTER

NOTICE

Indicator lamps vary by model.

NOTICE

High water pressure may damage components. Wash the TRACTOR by hand or with a garden hose using mild soap. Certain products, including insect repellents and chemicals, will damage the speedometer lens and other plastic surfaces. Do not use alcohol or cleaning products containing alcohol to clean the instrument cluster. Do not allow insect sprays to contact the lens.

Immediately clean off any gasoline that splashes on the instrument cluster.

- ① Speedometer
- ④ Tachometer
- ② Indicator Lamps
- ⑤ Toggle Buttons
- ③ Rider Information Center
- ⑥ Mode Button

SPEEDOMETER



The speedometer displays TRACTOR speed in either miles per hour (MPH) or kilometers per hour (km/h).

TACHOMETER

The tachometer displays engine speed in revolutions per minute (RPM).

MODE BUTTON

Press and hold the MODE button ④ to enter or exit the settings menu.

Press and release the MODE button to cycle through Area 1 modes and to select an item.

FEATURES AND CONTROLS

TOGGLE BUTTONS

Press and release either toggle button (5) to cycle through the options menu or Area 2 modes. Press and hold either toggle button to reset an item. See further pages for details.

TIP

With the ignition key off, pressing the MODE button or either toggle button will power up the Rider Information Center for 10 seconds to allow viewing of the odometer and the clock.

OPERATING A DAMAGED TRACTOR









WARNING

Do not continue driving if you think or feel the TRACTOR may be damaged or if you were in a crash or rollover. Operating the TRACTOR while damaged or after a crash or rollover can cause loss of control, rollover, or accident, which can lead to serious injury or death. If you cannot safely transport the TRACTOR from its current position, contact a recovery and towing service.

After any crash, rollover, or other accident, have a EGIMOTORS dealer inspect the TRACTOR for possible damage, including seat belts, ROPS, brakes, suspension, and steering systems.

Be prepared in case your TRACTOR becomes damaged or disabled, especially in remote areas. Consider how to get help and prepare for weather conditions whenever you ride.

INDICATOR LAMPS

LAMP	INDICATES	CONDITION
MPH	TRACTOR Speed	When standard mode is selected, speed displays in miles per hour.
km/h		When metric mode is selected, speed displays in kilometers per hour.
	Over Temperature	This lamp illuminates to indicate an overheated engine. If the indicator flashes, the overheating condition remains, and the system will automatically reduce engine power.
	Electric Power Steering (EPS) Warning (if equipped)	This indicator illuminates briefly when the key is turned to the ON position. If the light remains on, the EPS system is inoperative. See your EGIMOTORS dealer, or other qualified person, as soon as possible for repair. Continued operation could result in permanent damage to the EPS unit and increased steering effort.
	High Beam	This lamp illuminates when the headlamp switch is set to high beam.
	Helmet/Seat Belt	This lamp is a reminder to the operator to ensure all riders are wearing helmets and seat belts before operating.
	Check Engine	This indicator appears if an Electronic Fuel Injection (EFI) related fault occurs. Do not operate the TRACTOR if this warning appears. Serious engine damage could result. Your authorized dealer or qualified person can assist.
	Check Battery	This warning usually indicates that the TRACTOR is operating at an RPM too low to keep the battery charged. It may also occur when the engine is at idle and high electrical load (lights, cooling fan, accessories) is applied. Drive at a higher RPM or recharge the battery to clear the warning.
	Low Fuel	This lamp illuminates when fuel level in the fuel tank is low.
	Chassis Warning	If a fault condition is detected, the light will remain on as long as the condition exists. Retrieve the error codes for diagnosis. This lamp is also known as an Amber Warning Lamp (AWL).
	Operator presence	Lamp illuminates when driver is not detected on the seat, in addition an acoustic signal is present. Note: It is located on the main dash.

FEATURES AND CONTROLS

RIDER INFORMATION CENTER

①	AWD Indicator	This indicator shows whether 2X4 or AWD is active.
②	Fuel Gauge	The segments of the fuel gauge show the level of fuel in the fuel tank. When the last segment clears, a low fuel warning is activated. The outline of the fuel display will flash. Refuel immediately.
③	Service Indicator	A flashing wrench symbol alerts the operator that the preset service interval has been reached. Your EGIMOTORS dealer, or other qualified person, can provide scheduled maintenance. See further pages for resetting instructions.
④	Gear Indicator	This indicator displays gear shifter position. H = High Gear L = Low Gear N = Neutral R = Reverse Gear P = Park – = Gear Signal Error (or shifter between gears)
⑤	Speed Limitation (if equipped)	This TRACTOR may be equipped with a maximum speed limitation function. This would be displayed on the screen as “LIM” followed by the speed. “LIM 30” for example.

The rider information center is located in the instrument cluster. All segments will light up for one second at start-up. If the instrument cluster fails to illuminate, a battery over-voltage may have occurred and the instrument cluster may have shut off to protect the electronic speedometer. If this occurs, your EGIMOTORS dealer, or other qualified person, can provide proper diagnosis.

The information center is set to display standard units of measurement and a 12-hour clock at the factory. To change to metric and/or a 24-hour clock hold the mode button and cycle to the clock menu. Use the directional arrows to change the clock settings.

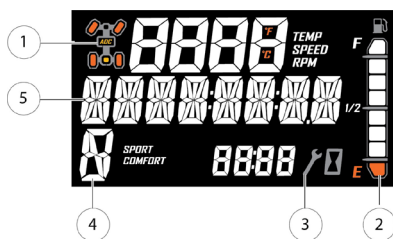

MODE INFORMATION DISPLAYS

The rider information center contains three areas that display mode information.

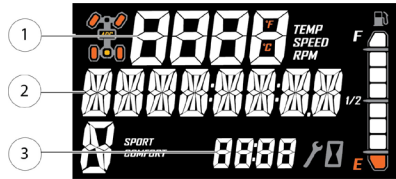

① Area 1 Modes	Description
Engine Temperature	Temperature of engine coolant
TRACTOR Speed	Speed of TRACTOR
Tachometer	Engine speed (RPM)
② Area 2 Modes	Description
Odometer	The odometer records and displays the distance traveled by the TRACTOR.
Trip Meters (T1/T2)	A trip meter records the distance traveled by the TRACTOR if reset before each trip. To reset, see further pages.
Engine Hours	Total hours of engine operation since manufacture
Service Hours	A flashing wrench symbol indicates that the preset service interval has been reached. To reset, see further pages.
Trip Time	Time length of TRACTOR operation since mode was last reset
③ Area 3 Modes	Description
Clock	The clock displays time in a 12-hour or 24-hour format. To reset, see further pages

FEATURES AND CONTROLS

ACCESSING MENUS AND OPTIONS

GAUGE SETTINGS MENU

Press and release the MODE button to cycle through the Area 1 modes until the desired default mode displays. See the Mode Information Displays section for details.

Press and hold the MODE button to enter the settings menu.

The OPTIONS screen will display for a few seconds.

1. Press and release either toggle button to cycle to the desired option.
2. Press MODE to select the option.
3. Press either toggle button to cycle to the desired setting.
4. Press MODE to save and exit to the settings menu.
5. Press and hold the MODE button to exit the settings menu.



BACKLIGHT BRIGHTNESS

The information center backlight can be set to either blue or red.

1. Press and hold the MODE button to enter the settings menu.
2. Press either toggle button to cycle to the "BL LEVEL" option. Press MODE to select.
3. Press "UP" button to increase brightness. Press "DOWN" button to decrease brightness.
4. Press MODE to select and exit to the settings menu.



CLOCK

The clock must be reset any time the battery has been disconnected or discharged.

1. Press and hold the MODE button to enter the settings menu.
2. Press either toggle button to cycle to the "CLOCK" option. Press MODE to select.
3. Press either toggle button to cycle to the desired setting (12H or 24H). Press MODE to select.
4. Press either toggle button to change each segment of the clock. Press MODE to accept a change and advance to the next segment.



DISPLAY UNITS (STANDARD/METRIC)

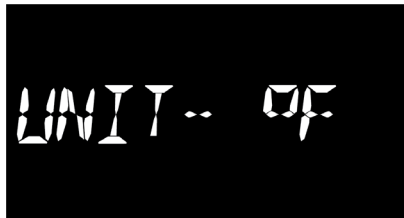

FEATURES AND CONTROLS

1. Press and hold the MODE button to enter the settings menu.
2. Press either toggle button to cycle to the desired "UNITS" option (distance, temperature or volume). Press MODE to select.
3. Press either toggle button to cycle to the desired setting.
4. Press MODE to save and exit to the settings menu.

TRIP METER

Use a trip meter to track the distance traveled during a specific trip or period of time. Reset the meter to zero before traveling.

1. Press either toggle button to cycle to the desired trip meter option (T1 or T2).
2. Press and hold either toggle button until the meter resets to zero.



TRIP TIME

Use a trip time meter to track the travel time during a specific trip. Reset the meter to zero before traveling.

1. Press either toggle button to cycle to the trip time option (TT).
2. Press and hold either toggle button until the meter resets to zero.



PROGRAMMABLE SERVICE INTERVAL

The service interval counter is programmed to 25 hours at the factory. As hours of engine operation increase, the counter decreases. The wrench icon will flash for about 10 seconds when the counter reaches zero (0), and each time the key is turned on thereafter, until the counter is reset.

When this feature is enabled, it provides a convenient reminder to perform routine maintenance. Refer to the EGIMOTORS Maintenance Schedule for recommended service intervals.

Use the following procedure to reset or change the service interval.

1. Press and hold the MODE button to enter the settings menu.
2. Press either toggle button to cycle to the "Service Hours" option. Press MODE to select.
3. Press MODE to reset the existing value and exit, or press either toggle button to change the value. Press MODE to save and exit to the settings menu.



FEATURES AND CONTROLS

PIN ACTIVATED SECURITY SYSTEM (P.A.S.S.) (IF EQUIPPED) — INSTRUMENT CLUSTER

For TRACTORS with a display, see the Ride Command section for details.

The optional PIN Activated Security System (P.A.S.S.) is designed to prevent unauthorized use. When enabled, the TRACTOR cannot be operated until a valid passcode has been entered.

To enable/disable P.A.S.S., follow the procedures below.

ENABLE P.A.S.S.

NOTICE

After activating P.A.S.S. for the first time you must power down the TRACTOR and allow the electronic control module (ECM) to fully shutdown before restarting.

This may take up to three minutes.

Once a new passcode has been enabled, it cannot be changed unless you first disable the system. Then you can re-follow the steps outlined in the ENABLE P.A.S.S. section to enter a new passcode.

1. Press and hold the MODE button to enter the “OPTIONS” menu.
2. Use the UP/DOWN toggle buttons to cycle through options until “REQUIRE PIN TO START” appears. Press the MODE button to select.
3. If required, “ENTER NEW PIN” will appear. Use the UP/DOWN toggle buttons to cycle to your desired first digit. Press the MODE button to select the digit.
4. Continue until all four digits of your desired passcode have been selected. Once finished, “NEW PIN SET” will flash momentarily and then revert back to the “REQUIRE PIN TO START” screen.
Record your passcode for future reference.
5. To enable your new passcode, use the UP/DOWN toggle buttons to change the flashing “OFF” at bottom of screen to “ON”. **If this step is skipped, P.A.S.S. will not be enabled.**
6. Press the MODE button to re-enter the “OPTIONS” menu. The TRACTOR will now require passcode entry before next startup.

You can exit the “OPTIONS” menu three different ways.

- Toggle to “EXIT” and press the MODE button.
- Hold the MODE button for a few seconds.
- Do nothing, allowing the system to automatically revert back to the main screen.

NOTICE

If the battery becomes low while the P.A.S.S. system is enabled, the gauge may show "New TRACTOR Detected" after the battery has been recharged/replaced. Leave the key in the ON position to allow system reconfirmation.

DISABLE P.A.S.S.

1. Press and hold the MODE button to enter the "OPTIONS" menu.
2. Use the UP/DOWN toggle buttons to cycle through options until "REQUIRE PIN TO START" appears. Press the MODE button to select.
3. Enter current passcode.
4. Use the UP/DOWN toggle buttons to change the flashing "ON" at bottom of screen to "OFF".
5. Press the MODE button to re-enter the "OPTIONS" menu. P.A.S.S. is now disabled.

You can exit the "OPTIONS" menu three different ways.

- Toggle to "EXIT" and press the MODE button.
- Hold the MODE button for a few seconds.
- Do nothing, allowing the system to automatically revert back to the main screen.

FEATURES AND CONTROLS

ENGINE ERROR CODES

The error screen displays only when the CHECK ENGINE indicator is on or when it goes on and off during one ignition cycle. Error codes are not stored. When the key is turned OFF, the code and message is lost, but will reappear if the fault reoccurs after restarting the engine.

If the CHECK ENGINE lamp or the EPS lamp illuminates, retrieve the active error codes from the display.

- ① Failure Mode Indicator (FMI)
- ② Suspect Parameter Number (SPN)
- ③ Code Count

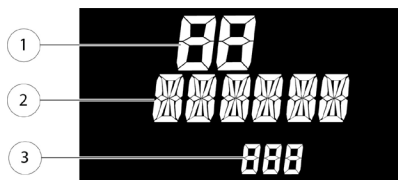

1. Press and hold the MODE button to enter the settings menu.
2. Press either toggle button to cycle to the "DIAGCODE" option. Press MODE to select.
3. More than one diagnostic code may be present. Press the toggle UP button to see if more codes are present. Press MODE to select a code.

NOTICE

If the displayed code is an engine fault code, the CHECK ENGINE lamp will blink. If the displayed code is an EPS fault code, the EPS lamp will blink.

4. Record the three (3) numbers displayed.
5. Press MODE to exit to the settings menu.

DYNAMIX ACTIVE SUSPENSION (IF EQUIPPED) OVERVIEW

 **WARNING**

Driving while distracted can result in loss of TRACTOR control, crash, and injury. We strongly recommend that you use extreme caution when using any device that may take your focus off of driving. Your primary responsibility is the safe operation of your TRACTOR.

Dynamix Active Suspension (if equipped) is the industry's most advanced suspension system, offering unprecedented control and comfort for any riding condition you experience with your *RZR*. Dynamix Active Suspension is an electronically controlled suspension system designed to optimize TRACTOR comfort and handling through continuously monitoring the driver's inputs and TRACTOR motion, and controlling the suspension in real-time.

Dynamix Active Suspension features FOX® electronically controlled shocks driven by a custom EGIMOTORS-designed Suspension Control Module (SCM). The suspension control algorithms and software were designed and developed by EGIMOTORS' engineering team, leveraging our expertise and deep knowledge of off-road TRACTOR dynamics. Dynamix Active Suspension proactively makes split-second decisions based on operator inputs, controlling the shocks to achieve optimum performance, control, and stability under varying riding conditions and driving styles.

FEATURES AND CONTROLS

WARNING

Do not enter information while operating your TRACTOR. Failure to pay attention to operating your TRACTOR could result in loss of control, injury, or death. You assume all risks associated with using this device. Read your User Guide. Always ride with the latest maps and trails data. For more information ask EGIMOTORS.

Your TRACTOR is equipped with an advanced Ride Command display. The suspension control screen provides additional information about the operation of your Dynamix Active Suspension system.

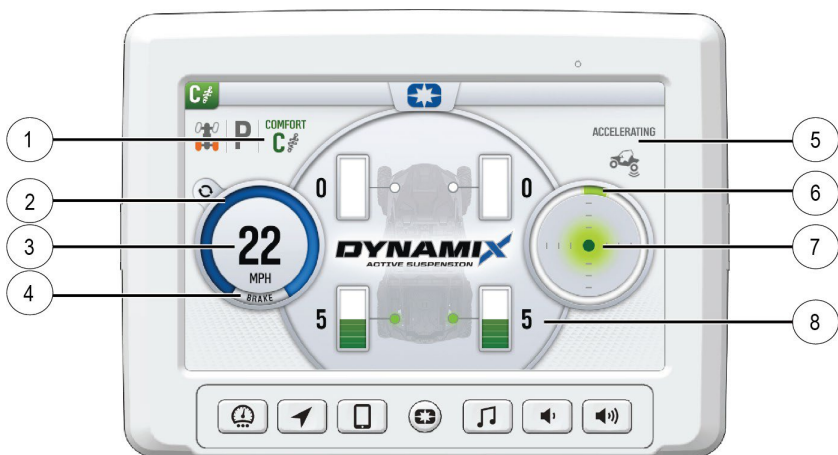

- | | |
|--------------------------------|--------------------------------------|
| ① Current Suspension Ride Mode | ⑤ Active TRACTOR Event State Pop-ups |
| ② Accelerator Pedal Position | ⑥ Steering Angle |
| ③ TRACTOR Speed | ⑦ G-Meter |
| ④ Brake Status | ⑧ Current Damping Setting |

DYNAMIX™ SYSTEM COMPONENTS

SUSPENSION CONTROL MODULE (SCM)

The Suspension Control Module (SCM) contains the logic for suspension control, including communications, operator inputs, and shock drivers. The SCM also has an internal 6-axis inertial measurement unit which is used to monitor the performance of the TRACTOR by the suspension control algorithms.



Moving or altering the SCM may have an adverse effect on TRACTOR handling.

Never move the SCM from its factory mounting location.

ELECTRONIC POWER ASSISTED STEERING (EPAS)

The Electronic Power Assisted Steering (EPAS) system has been enhanced with a steering angle sensor to provide steering angle information to the SCM.

ELECTRONIC SHOCK DAMPING CONTROL

Your suspension has electronically controlled, independent compression and rebound shock damping. This is used to control how fast the shocks compress and extend.

Compression Damping: Force acting against a shock movement in the compressing direction (shock length becoming shorter). When a shock is being compressed, lower compression damping results in faster compression movement and higher compression damping results in a stiffer, slower compression movement.

DYNAMIX SYSTEM FEATURES

TRACTOR SPEED SENSITIVITY

The system continuously monitors the speed of the TRACTOR and adjusts to a base level of compression damping for a given TRACTOR speed depending on the mode selected by the user.

CORNERING CONTROL

The system continuously monitors steering angle, lateral acceleration, and TRACTOR yaw rate to provide enhanced cornering control, reducing body roll for maximum performance.

FEATURES AND CONTROLS

BRAKING

The system continuously monitors the brake pedal position and TRACTOR deceleration rate, reducing body motion, and increasing available compression travel for braking into harsh terrains.



ACCELERATION

The system continuously monitors TRACTOR speed, and accelerator pedal position to increase damping of the rear shocks under high straight line acceleration conditions to keep the TRACTOR level.



AIRBORNE DETECTION

The system continuously monitors the state of the TRACTOR using its 6-axis inertial measurement unit. When low-g situations are encountered, the system provides maximum damping until the low-g situation is no longer present, after which it reverts back to the user-selected drive mode.



ADVANCED DIAGNOSTICS

The system continuously monitors the health and state of all input and output signals. If a fault is detected, the system reverts to a safe operating state and alerts the operator of a component or system problem.

PROCESSING CAPABILITY

DYNAMIX™ Active Suspension controls current to the shock valve 1000 times per second, performs TRACTOR dynamics calculations 200 times per second, and can actuate a shock from soft to firm approximately 20 times per second.

FEATURES AND CONTROLS

DYNAMIX RIDE MODES

This RZR is equipped with a suspension control mode switch that allows you to change the suspension control mode of your DYNAMIX™ Active Suspension system on-the-fly. Ride modes can be cycled through using the “up/down” button on the steering wheel. It will not cycle from top to bottom with an “up” button press.

There are 3 available drive modes to select from: Comfort, Sport, and Firm.

⚠ WARNING

The rider should use caution to select the appropriate ride mode to match the current terrain conditions and driving style. Failure to select an appropriate ride mode could lead to TRACTOR dynamic behaviors not matched to the terrain or driver's skill level.

NOTICE

The system will prevent mode transitions when a current active TRACTOR state is present (cornering, braking, accelerating, or airborne).

COMFORT

In Comfort mode, the suspension control system is primarily optimized for rider comfort. Damping is adjusted least aggressively for each TRACTOR event. This mode is ideal for non-aggressive driving and rides with smaller suspension inputs, such as cruising home at the end of the day.



SPORT

In Sport mode, some level of rider comfort is traded for higher performance levels and reduced body motion. Damping is adjusted most aggressively for each TRACTOR event. This mode is ideal for spirited driving where additional suspension system performance is required.



FIRM

In Firm mode, the suspension control system provides the most firm compression damping. Damping is adjusted aggressively for each TRACTOR event. This mode is recommended for challenging terrain where large suspension travel events and complex terrain are encountered.



If your TRACTOR is equipped with Instantaneous Compression the suspension compression damping reverts to a firm base-damping setting with aggressive active TRACTOR events to respond to harsh terrain. If your TRACTOR is not equipped with Instantaneous Compression, all 4 shocks are set to the most firm setting.

FEATURES AND CONTROLS

INSTANTANEOUS COMPRESSION (IF EQUIPPED)

The Instantaneous Compression button allows you to immediately apply full compression damping to all 4 shocks in any handling mode for the full duration of holding the button plus a short delay time. This is intended to be used when encountering unsuspected TRACTOR events or obstacles to avoid bottom-out or occupant discomfort.

DYNAMIX INSTANT COMPRESSION BUTTON

When the DYNAMIX button is **single pressed**, the system will increase compression damping to improve bottom out performance. The increased compression will persist as long as the button is pressed and momentarily after the button is released. This allows the TRACTOR to better absorb what the driver will encounter ahead, such as an obstacle, a hole on the trail or a G-Out when dune riding.

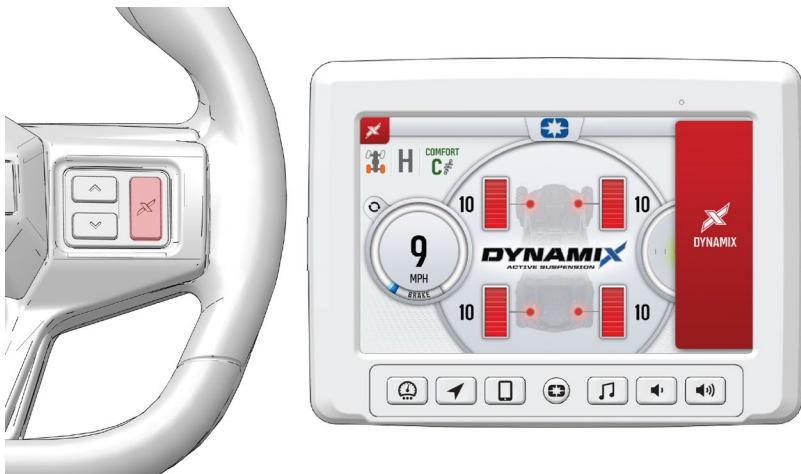

When the DYNAMIX button is **double pressed quickly**, the increased compression damping will latch ON. Double pressing again or changing the ride mode will immediately exit this damping.

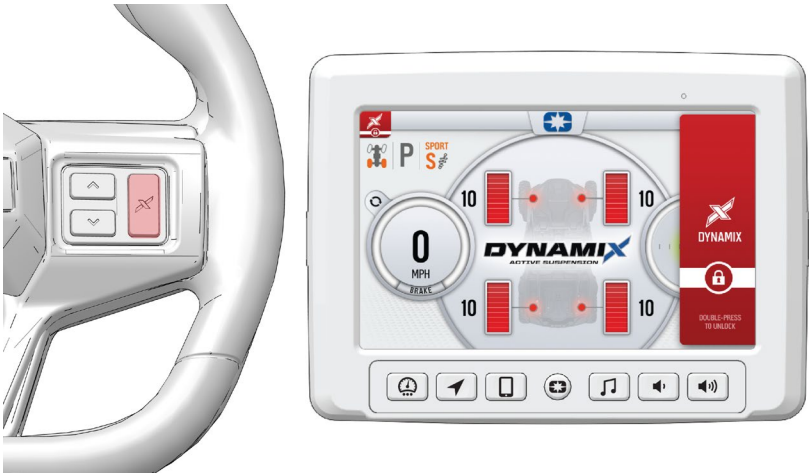

NOTE

This feature behaves the same way in each Ride Mode.

DEMONSTRATION MODE

“Demo” Mode allows the operator to see each Ride Mode before actual use. Activate “Demo” Mode by placing the TRACTOR in Park (P) and turning off the engine, then turn the ignition key switch to the ON position. The operator can cycle through the different Ride Modes using the UP or DOWN arrow buttons, then use the throttle, brakes, and steering wheel to assess each Ride Mode. In Demo Mode, the shocks will be red on the display.

7" DISPLAY BY RIDE COMMAND (IF EQUIPPED)

BEFORE YOU RIDE

Before riding with your new display, do the following:

- Read this section and the Ride Command User Guide in their entirety.
- Familiarize yourself with the features and operations of the display while the TRACTOR is stationary.
- Download the EGIMOTORS RIDE COMMAND App from the Apple® App Store® or Google Play® store and create your personalized account.
- Check your display to ensure you have the appropriate maps and trails visible for your area. To change or update maps/trails see further pages.
- Check <https://www.egimotors.it> for the latest updates to the owner's manual.

NOTICE

Trails change often, and the trail data file is only considered valid for 90 days after the release date. Please keep your trail data up to date. Download the latest trails at <https://ridecommand.polaris.com/display>

NOTICE

Using the display for an extended period of time while the TRACTOR's engine is off can drain the battery.

DEVICE OPERATING REQUIREMENTS

Phone functionality is dependent on the capabilities of your cell phone.

NOTICE

Some cell phones or operating systems will not work as shown in this manual.

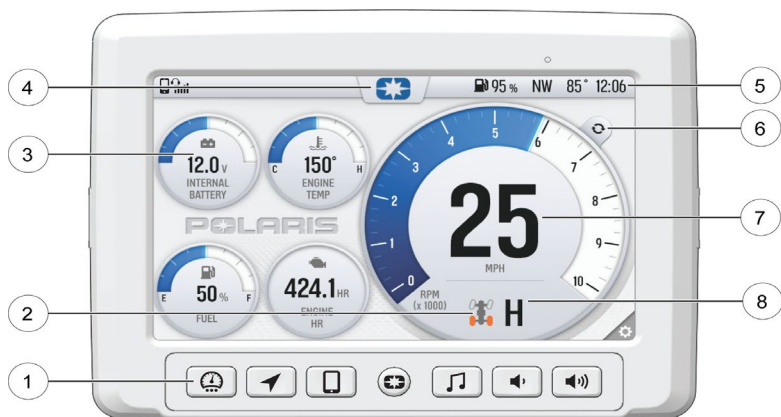

7" DISPLAY BY RIDE COMMAND (IF EQUIPPED)

OVERVIEW







- ① Ride Command Buttons
- ② Driveline Mode
- ③ Widgets
- ④ Settings
- ⑤ Icon Bar
- ⑥ Gauge View Mode
- ⑦ Speedometer/Tachometer
- ⑧ Gear Status

RIDE COMMAND BUTTONS

BUTTON	DESCRIPTION	FUNCTION
	Menu Button	Press the Menu button to access the settings. To reboot the display, press and hold for 5 seconds.
	Gauge Screen Button	Press the Gauge Screen button to select from available screens.

7" DISPLAY BY RIDE COMMAND (IF EQUIPPED)

BUTTON	DESCRIPTION	FUNCTION
	Map Button	Press the Map button to access the map, manage your rides and waypoints, and to see your friends on the map with Group Ride.
	Phone Button	Press the Phone button to access your Bluetooth® connected phone, including recent calls, contacts, dialer, and messages.
	Audio Button	Press the Audio button to access the Radio, Weather, USB, and connected Bluetooth® music interface
	Volume Decrease Button	Press the Volume Decrease button to decrease the volume. Press and hold to mute volume.
	Volume Increase Button	Press the Volume Increase button to increase the volume.

7" DISPLAY BY RIDE COMMAND (IF EQUIPPED)

DRIVELINE MODE

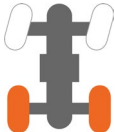
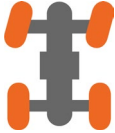
INDICATOR	DESCRIPTION	FUNCTION
	2WD	When the switch is on 2X4, the TRACTOR is in two-wheel drive at all times.
	AWD	When in All-Wheel Drive, the demand drive unit will automatically engage any time the rear wheels lose traction. When the rear wheels regain traction, the demand drive unit will automatically disengage. There is no limit to the length of time the TRACTOR may remain in 4X4. The TRACTOR automatically engages 4X4 when operating in reverse if the switch is set to 4X4 position.

7" DISPLAY BY RIDE COMMAND (IF EQUIPPED)

GAUGE SCREENS

Press the Gauge Screen button to toggle between gauge screens. The display comes loaded with two different gauge screens. Additional gauge screens can be added or deleted.

Each gauge screen is customizable and can be set up in the following configurations:

- Four round widgets
- Two round widgets and a list of three data values
- A list of five data values

To customize your gauge screens, press the gear icon located in the lower right corner of the display.



SETTINGS

From the Setting menu you can view TRACTOR information, manage Bluetooth® devices, update display software, and more.

To access the Setting menu, press the Menu button (1) or the star logo at the top of the display screen (2).

This will open the Badge Panel. From the Badge Panel, press the **All Settings** button located in the lower right corner of the display screen.



7" DISPLAY BY RIDE COMMAND (IF EQUIPPED)

GAUGE VIEW MODE

Press ① to toggle between the two available gauge view modes, **Analog** and **Digital**.

While in the digital gauge view mode, press ② to invert the MPH and RPM units.



DISPLAY MODE

From the Control tab ④, select the display mode from the available options ⑥. The display mode can be set to Day, Night, or AUTO mode.

Day Mode



Night Mode



7" DISPLAY BY RIDE COMMAND (IF EQUIPPED)

ICON BAR

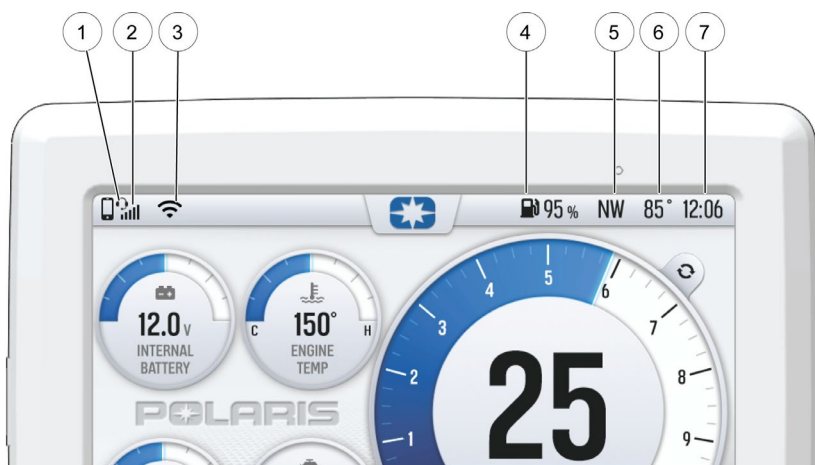

ICON	DESCRIPTION	FUNCTION
①	Headset	Displays icon if headset is connected
②	Signal Strength	Displays current cell signal strength
③	Wireless Internet Signal Strength (if equipped)	Displays current wireless internet signal strength (if equipped)
④	Fuel Level	Displays current fuel capacity percentage
⑤	TRACTOR Direction	Displays TRACTOR direction
⑥	Ambient Temperature	Displays ambient temperature
⑦	Clock	Displays current time

7" DISPLAY BY RIDE COMMAND (IF EQUIPPED)

PIN ACTIVATED SECURITY SYSTEM (P.A.S.S.) (IF EQUIPPED) — RIDE COMMAND

The optional PIN Activated Security System (P.A.S.S.) is to prevent unauthorized use. When enabled, the TRACTOR cannot be operated until a valid passcode has been entered using the Ride Command display screen.

ENABLE P.A.S.S.

NOTICE

After activating P.A.S.S. for the first time you must power down the TRACTOR and allow the electronic control module (ECM) to fully shutdown before restarting.

This may take up to three minutes.

1. Go the settings menu by pressing the Menu button.
2. Select TRACTOR Settings from the left toolbar.
3. Select Engine Start Lockout.
4. If this your first time activating P.A.S.S. you will be prompted to enter a new passcode. Enter and verify new passcode.
Record your passcode for future reference.
5. Turn Engine Start Lockout from No to Yes.
6. Turn off the TRACTOR using the key ignition switch.

NOTICE

If the battery becomes low while the P.A.S.S. system is enabled, the gauge may show "New TRACTOR Detected" after the battery has been recharged/replaced. Leave the key in the ON position to allow system reconfirmation.

DISABLE P.A.S.S.

1. Go the settings menu by pressing the Menu button.
2. Select TRACTOR Settings from the left toolbar.
3. Select Engine Start Lockout.
4. Enter passcode to disable P.A.S.S.
5. Turn Engine Start Lockout from Yes to No.

UPDATE SOFTWARE

NOTICE

Before updating the display, always export your existing rides and waypoints to a USB drive to avoid losing them.

To update the software, do the following:

DOWNLOAD SOFTWARE ONTO YOUR PERSONAL COMPUTER

1. Go to ridecommand.polaris.com/display. Select the display that matches what is on your TRACTOR.
2. Click the **Update Software** button.
3. Save the file to a removable USB drive. It is recommended you use a USB drive with 32GB in exFAT® format.

UPLOAD SOFTWARE ON YOUR TRACTOR

1. Plug the USB drive into your TRACTOR's USB cable and turn on the display.
Note: ensure the USB is fully inserted into the port.
2. Turn on your TRACTOR.
3. On the display, press the EGIMOTORS icon button.
4. In the right-hand corner, select **All Settings**.
5. Select **General**.
6. Select **System Information**.
7. Select the file you want to install. "Newest" will be automatically displayed next to the newest version detected on the USB drive.
8. The display will reboot and install the software.

ERROR MESSAGES AND TROUBLESHOOTING

If an error occurs while updating your software, perform one or all of the following actions to resolve the issue:

- Remove and reconnect the USB flash drive securely.
- Make sure the display files are not inside a folder on the flash drive.
- Make sure only display files are on the flash drive. Remove any other files if necessary.
- Try using a different USB flash drive.

7" DISPLAY BY RIDE COMMAND (IF EQUIPPED)

- Ensure the capacity of data on the USB drive is larger than 1GB and smaller than 64GB.
- Re-format the flash drive to the correct format (FAT32 or exFAT®).
Re-download the update(s) from the RIDE COMMAND website. Drag and drop the file(s) into the flash drive folder.

UPDATE MAPS

To update the maps on your display, do the following:

1. Go to ridecommand.EGIMOTORS.com/display and download the map update to a USB flash drive.
2. Insert USB flash drive into the USB port on your TRACTOR.
3. Press the Update maps in the General Settings.
4. Select the file you want to install by pressing the corresponding down arrow icon.
5. This will update the display's map which will automatically restart the display once the update is complete. Do not remove the USB flash drive until the display has fully restarted.

USB HARDWARE

SOFTWARE UPDATES

For software update, EGIMOTORS recommends using a SanDisk® or similar USB flash drive with a minimum of 1GB or larger in available memory, formatted using the exFAT® file system. For best results remove all files from the flash drive before starting the update process.

MAP, TRAIL AND POINT OF INTEREST UPDATES

For Map, Trail and Point of Interest updates, a 32GB or larger USB drive is required (USB 3.0 drive is highly recommended). USB drive must be formatted to exFAT® before copying the map file onto it.

OPERATION

TRACTOR BREAK-IN

ENGINE AND DRIVETRAIN BREAK-IN

1. Fill the fuel tank with the recommended fuel. See the Refueling section for details. Always exercise extreme caution whenever handling fuel.
2. Check the oil level. See the Oil Check section for details. Add the recommended oil as needed to maintain the oil level in the safe operating range.
3. Avoid aggressive use of the brakes.
4. Vary throttle positions. Do not operate at sustained idle.
5. Perform regular checks on fluid levels, controls and areas outlined on the daily pre-ride inspection checklist.
6. Carry only light loads.
7. During the break-in period, change both the oil and the filter at 25 hours, one month, or 800km, whichever comes first.
8. Check fluid levels of transmission and all gearcases according to the Maintenance Schedule.

BRAKE SYSTEM BREAK-IN

Apply only moderate braking force for the first 50 stops. Aggressive or overly forceful braking when the brake system is new could damage brake pads and rotors.

OPERATION

BRAKE BURNISHING

It is recommended that a burnishing procedure be performed on new TRACTORS or after installation of new brake pads or rotors. This helps to conform the pads to the rotor surface and achieve optimum braking performance.

Test drive the machine and gradually accelerate to more than 32 km/h. Apply light to moderate pressure to the brake pedal to slow the TRACTOR to roughly 8 km/h. Repeat this process 10–30 times, allowing 30 seconds between brake applications for the system to cool down.

IMPORTANT

Do not stop aggressively and do not slow to a complete stop during the burnishing process. After brake burnishing is complete, drive the TRACTOR to cool the brake pads and rotors.

NOTICE

The burnishing process may cause there to be brake dust on the wheels and calipers. This is normal. When the system has cooled, use a rag and soapy water (no harsh chemicals) to clean off the dust.

PVT BREAK-IN (CLUTCHES / BELT)

A proper break-in of the clutches and drive belt will ensure a longer life and better performance. If a belt fails, always clean any debris from the duct and from the engine compartment.

STANDARD BREAK-IN

Drive at slower speeds for the first 80 km of operation. Carry only light loads. Avoid aggressive acceleration, high-speed operation and prolonged operation at a specific RPM during this period.

SAND / DUNE BREAK-IN

Drive in low gear for the first 8 km of operation. Avoid prolonged low speed operation at high throttle. Avoid aggressive acceleration, high-speed operation and prolonged operation at a specific RPM during this period.

BELT LIFE

To extend belt life, use low gear in the following conditions:

- When hauling or towing heavy cargo.
- When consistently operating at speeds less than 56 km/h in hard-pulling terrain, such as mud, rocks or sand/dune environments.

OPERATING GUIDELINES

REFUELING

The fuel tank filler cap is located on the right side of the TRACTOR near the passenger seat.

The fuel symbol and the last fuel bar on the Instrument Cluster will blink when the fuel level reaches 1/8th tank. There will be approximately 8 L of fuel remaining. Refuel as soon as possible. *Do not allow the TRACTOR to run out of fuel.*

To refuel:

1. Place the transmission into Park on a level surface.
2. Turn off the engine.
3. Make sure no one is inside the TRACTOR.
4. Fill with fuel, leaving the tank neck empty.
5. Securely close fuel cap.

NOTE

Gasoline can expand while inside the tank. To avoid fires and explosions, do not overfill the tank. Allow room for gasoline to expand inside the tank by leaving the tank neck empty.

- Use minimum 91 octane (or higher) unleaded fuel (minimum pump octane number of 91 R+M2).
- Do not use any fuel lower than 91 octane.
- Do not use any fuel containing more than 10% ethanol (including E85).

NOTICE

Damage to the fuel pump will occur if the TRACTOR is operated with an empty fuel tank. Do not allow the TRACTOR to run out of fuel. Always refuel when the level is low.

NOTICE

Operating with obstructed fuel systems will result in serious engine damage. Perform maintenance as recommended.

NOTICE

Prolonged exposure to petroleum based products may damage paint. Always protect painted surfaces when handling fuel.

OPERATION

FUEL RECOMMENDATION

Fuel used should be purchased during the season of Tractor usage to provide the best engine performance (starting, run quality, fuel economy, and power) and durability.

Octane Rating

EGIMOTORS recommends a minimum of 91 Octane (R+M/2) rated gasoline. Using lower octane gasoline could result in engine damage.

STARTING THE ENGINE

NOTICE

Operating the TRACTOR immediately after starting could cause engine damage. Allow the engine to warm up for several minutes before operating the TRACTOR.

1. Position the TRACTOR on a level surface outdoors or in a well-ventilated area.
2. Sit in the driver's seat and fasten the seat belt. Always make sure all cab doors are closed and latched when riding in this TRACTOR.
3. Place the transmission in PARK.
4. Apply the brakes. Do not press the throttle pedal while starting the engine.
5. Turn the ignition key past the ON/RUN position and release immediately to START. The engine will turn over for a maximum five seconds until the TRACTOR has started.
6. If the engine does not start within five seconds, return the ignition switch to the OFF position and wait five seconds. Repeat steps 5 and 6 until the engine starts.
7. After starting the engine, wait 10 seconds before applying throttle.

BRAKING

1. Release the throttle pedal completely.

TIP

When the throttle pedal is released completely and engine speed slows to near idle, the TRACTOR has no engine braking.

2. Press on the brake pedal evenly and firmly.
3. Practice starting and stopping (using the brakes) until you're familiar with the controls.

DRIVING IN REVERSE

WARNING

Before shifting into reverse, use extra care to make sure the area is clear of people or obstacles. When it's safe to proceed, back slowly.

Follow these precautions when operating in reverse:

1. Always check for obstacles or people behind the TRACTOR.
2. Apply the throttle *lightly*. Never open the throttle suddenly.
3. Back slowly.
4. Apply the brakes *lightly* for stopping.
5. Avoid making sharp turns.

STOPPING THE ENGINE AND PARKING THE TRACTOR

WARNING

When leaving the TRACTOR on an incline is unavoidable, use extra care. TRACTOR rollaway can cause serious injury or death. This TRACTOR can roll whenever the gear selector is not in the PARK (P) position. Always shift to PARK (P) when stopping the engine or leaving the TRACTOR. If leaving the TRACTOR unattended, block the rear wheels on the downhill side and keep children, pets, and others away from the gear selector.

To park the TRACTOR:

1. Stop the TRACTOR on a level surface.
2. Place the transmission in PARK (P). This TRACTOR can roll whenever the transmission is not in the PARK (P) position.
3. Stop the engine.
4. Engage the park brake (if equipped).
5. Remove the ignition key to prevent unauthorized use.

EMISSION CONTROL SYSTEMS

NOISE EMISSION CONTROL SYSTEM

Do not modify the engine, intake or exhaust components, as doing so may affect compliance with governmental noise level requirements.

CRANKCASE EMISSION CONTROL SYSTEM

This engine is equipped with a closed crankcase system. Blow-by gases are forced back to the combustion chamber by the intake system. All exhaust gases exit through the exhaust system.

EXHAUST EMISSION CONTROL SYSTEM

Exhaust emissions are controlled by engine design. An electronic fuel injection (EFI) system controls fuel delivery. The engine and EFI components are set at the factory for optimal performance and are not adjustable.

The emissions label is located on the left front frame of the TRACTOR.

ELECTROMAGNETIC INTERFERENCE

This TRACTOR complies with EMC requirements of UN ECE Regulation 10 and European directives 97/24/EC and 2004/108/EC.

Non-ionizing Radiation: This TRACTOR emits some electromagnetic energy. People with active or non-active implantable medical devices (such as heart monitoring or controlling devices) should review the limitations of their device and the applicable electromagnetic standards and directives that apply to this TRACTOR.

MAINTENANCE

PERIODIC MAINTENANCE CHART

Any qualified repair shop or person may maintain, replace or repair the emission control devices or systems on your TRACTOR. An authorized EGIMOTORS dealer can perform any service that may be necessary for your TRACTOR. EGIMOTORS also recommends EGIMOTORS parts for emissions-related service, however equivalent parts can be used.

It is a potential violation of the Clean Air Act if a part supplied by an aftermarket parts manufacturer reduces the effectiveness of the TRACTOR's emission controls. Tampering with emission controls is prohibited by federal law.

Owners are responsible for performing the scheduled maintenance identified in this owner's manual.

Careful periodic maintenance will help keep your TRACTOR in the safest, most reliable condition. Inspection, adjustment and lubrication of important components are explained in the periodic maintenance chart.

Inspect, clean, lubricate, adjust and replace parts as necessary. When inspection reveals the need for replacement parts, genuine EGIMOTORS parts are available from your EGIMOTORS dealer. Equivalent parts may be used for emissions-related service.

Service and adjustments are important for proper TRACTOR operation. If you're not familiar with safe service and adjustment procedures, a qualified dealer can perform these operations.

TRACTORS subjected to heavy or severe use patterns must be inspected and serviced more frequently.

SEVERE USE DEFINITION

- Frequent immersion in mud, water or sand
- Racing or race-style high RPM use
- Prolonged low speed, heavy load operation
- Extended idle
- Frequent short trip operation in cold weather (engine frequently does not operate long enough to reach full operating temperature)
- Prolonged high speed operation, such as road travel

Pay special attention to the oil level. A rise in oil level during cold weather can indicate contaminants collecting in the oil sump or crankcase. Change oil immediately if the oil level begins to rise. Monitor the oil level, and if it continues to rise, discontinue use and determine the cause. Your EGIMOTORS dealer or other authorized person can assist.

MAINTENANCE

EGIMOTORS MAINTENANCE SCHEDULE

The intervals shown are based on TRACTORs operated under normal conditions.

Each interval is given in hours and kilometers. Items should be serviced at whichever interval comes first following the **Initial Break-In Service**.

Continue to reference the following maintenance schedules at the given intervals as hours and kilometers increase on the TRACTOR.

TRACTORs subjected to severe use must be serviced at 50% of the stated interval. Examples of Severe Use: Frequent immersion in mud, water, or sand, constant high RPM use, prolonged low-speed heavy load operation, extended idle, and short trip cold weather operation.

INITIAL BREAK-IN SERVICE FIRST 25 HOURS / 800 KM OR 1 MONTH

Engine Oil and Filter	Change the engine oil and filter.
Spark Arrestor	Inspect; clean as needed.
Air Filter	Inspect air filter; replace as necessary. Ensure proper installation of filter and airbox cover. Inspect ducts and screens; clean as necessary.
Cooling System	Fluid level inspection; inspect for fluid leaks; add coolant if needed. Inspect coolant strength seasonally; pressure test system yearly. Replace as necessary.
General Lubrication	Locate all applicable fittings and grease.
Shift Cable / Linkage	Inspect; adjust as needed
Parking Brake (if applicable)*	Inspect and adjust as needed.
Battery	Check terminals; terminals should be tight and free of corrosion. Clean, test, and replace as necessary.
Front Gearcase Fluid	Initial fluid level inspection; inspect for fluid leaks. Add lubricant if needed.
Transmission Fluid	Initial fluid level inspection; inspect for fluid leaks. Add lubricant if needed.
The break-in period consists of the first 25 hours of operation. Careful treatment of a new engine and drive components will result in more efficient performance and longer life for these components. The items outlined in this service interval only need to be performed at the first 25 hours of operation. They do not need to be performed every 25 hours.	
* It is recommended to have an authorized EGIMOTORS dealer perform these services.	

TRACTORS subjected to severe use must be serviced at 50% of the stated interval. Examples of Severe Use: Frequent immersion in mud, water, or sand, constant high RPM use, prolonged low-speed heavy load operation, extended idle, and short trip cold weather operation.

EVERY 25 HOURS / 800 KM OR 6 MONTHS FOLLOWING INITIAL BREAK-IN SERVICE

Air Filter	Inspect air filter; replace as necessary. Ensure proper installation of filter and airbox cover. Inspect ducts and screens; clean as necessary.
Battery	Check terminals; terminals should be tight and free of corrosion. Clean, test, and replace as necessary.
Brake System	Fluid level inspection; inspect for fluid leaks; add lubricant if needed. Inspect brake pad wear.
General Lubrication	Locate all applicable fittings and grease.
Radiator	Inspect; clean external surfaces.
Tires	Inspect; adjust pressure level as needed. Inspect wear and replace as needed.
* Have an authorized EGIMOTORS dealer or other qualified person perform these services.	

MAINTENANCE

TRACTORS subjected to severe use must be serviced at 50% of the stated interval. Examples of Severe Use: Frequent immersion in mud, water, or sand, constant high RPM use, prolonged low-speed heavy load operation, extended idle, and short trip cold weather operation.

EVERY 50 HOURS / 1600 KM OR YEARLY FOLLOWING INITIAL BREAK-IN SERVICE

Engine Oil and Filter	Change the engine oil and filter.
Front Gearcase Fluid	Change fluid.
Transmission Fluid	Change fluid.
Spark Arrestor	Inspect; clean as needed.
Air Filter	Inspect air filter; replace as necessary. Ensure proper installation of filter and airbox cover. Inspect ducts and screens; clean as necessary.
Battery	Check terminals; terminals should be tight and free of corrosion. Clean, test, and replace as necessary.
Brake System	Fluid level inspection; inspect for fluid leaks; add lubricant if needed. Inspect brake pad wear.
General Lubrication	Locate all applicable fittings and grease.
Radiator	Inspect; clean external surfaces.
Tires	Inspect; Adjust pressure level as needed; Inspect wear and replace as needed.
Spark Plug	Replace as needed.
Wiring	Inspect for wear, routing, and retention.
Drive Belt	Inspect; replace as needed.
Suspension Components / Alignment*	Inspect front and rear suspension bushings, and ball joints for loose or worn components; replace as needed. Inspect shock absorbers for leaks or damage.
Cooling System	Fluid level inspection; inspect for fluid leaks; add coolant if needed. Inspect coolant strength seasonally; pressure test system yearly. Replace as necessary.

MAINTENANCE

EVERY 50 HOURS / 1600 KM OR YEARLY FOLLOWING INITIAL BREAK-IN SERVICE

Wheel Bearings	Inspect; replace as needed
Parking Brake (if applicable)*	Inspect and adjust as needed.
Fuel System*	Cycle key to pressurize fuel pump; check for leaks at fuel system connections, check for leaks at fill cap.
Throttle Body / Intake Ducts / Flanges	Inspect ducts for proper sealing / air leaks
Shift Cable / Linkage	Inspect; adjust as needed
Steering Components	Inspect; replace as needed.
* Have an authorized EGIMOTORS dealer or other qualified person perform these services.	

TRACTORS subjected to severe use must be serviced at 50% of the stated interval. Examples of Severe Use: Frequent immersion in mud, water, or sand, constant high RPM use, prolonged low-speed heavy load operation, extended idle, and short trip cold weather operation.

ADDITIONAL MAINTENANCE INTERVALS

Every 24 months / 2 years	Brake Fluid	Change fluid.
Every 3200KM / 24 months / 2 years	Clutches*	Inspect bushings, rollers, wearable parts; clean; replace worn parts.
Every 4000KM	Shock Absorbers*	Inspect; replace or rebuild (if applicable).
Every 200 hours / 6400KM	Valve Clearance*	Inspect; adjust as needed.
Every 8000KM / 60 months / 5 years	Coolant	Change fluid.
* Have an authorized EGIMOTORS dealer or other qualified person perform these services.		

MAINTENANCE

LUBRICATION RECOMMENDATIONS

Check and lubricate all components at the intervals outlined in the Periodic Maintenance Chart or more often under severe use, such as wet or dusty conditions. Items not listed in the chart should be lubricated at the general lubrication interval.

ITEM	LUBE	METHOD
Engine Oil	PS-4 5W-50 4-Cycle Oil and PS-4 Extreme Duty 0W-50 4-Cycle Oil	See further pages.
Brake Fluid	DOT 4 Brake Fluid	Maintain level between fill lines.
Transmission Oil (Main Gearcase)	AGL Gearcase Lubricant & Transmission Fluid	See further pages.
Front Gearcase Fluid (Demand Drive)	Demand Drive Fluid	See further pages.
Prop Shaft	U-Joint Grease	Access through the skid plate access hole. Grease the fitting.
Rear Stabilizer Bar Bushings	All Season Grease or grease conforming to NLGI No. 2	Remove engine access panel and grease 2 fittings (one on each side of TRACTOR).

- ① Middle Prop Shaft Grease Fitting
- ② Rear Stabilizer Bar Bushings (one on each side of TRACTOR)

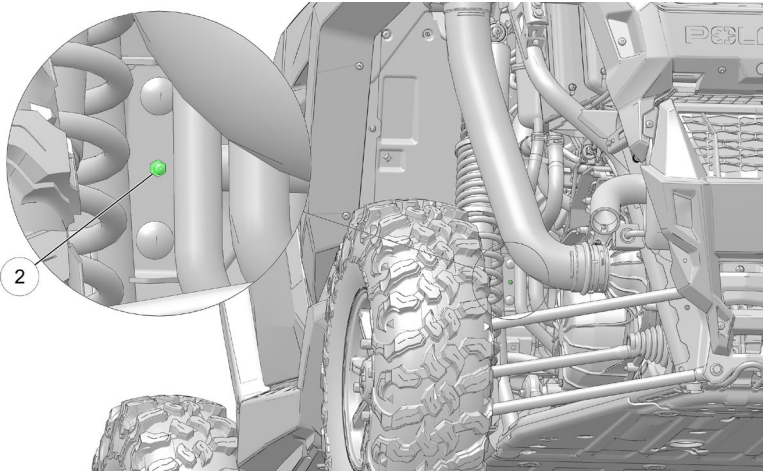
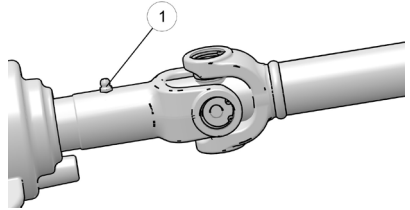

ENGINE OIL

OIL RECOMMENDATIONS

WARNING

TRACTOR operation with insufficient, deteriorated, or contaminated engine oil will cause accelerated wear and may result in engine seizure, accident, and injury.

Always perform the maintenance procedures as outlined in the Periodic

Ambient Temperature Range	Recommended Oil
(-37 °C) to (+38 °C)	PS-4 5W-50 4-Cycle Oil
(-43 °C) to (+54 °C)	PS-4 Extreme 0W-50 4-Cycle Oil

Oil may need to be changed more frequently if EGIMOTORS oil is not used. Do not use automotive oil. Follow the manufacturer's recommendations for ambient temperature operation. Part numbers can be found in the EGIMOTORS Products chapter.

NOTICE

Mixing brands or using a non-recommended oil may cause serious engine damage. Always use the recommended oil. Never substitute or mix oil brands.

Always check and change the oil at the intervals outlined in the Periodic Maintenance Chart. Always use the recommended engine oil.

ENGINE OIL CHECK

Always check the oil once the engine has cooled and on a level surface. Do not check the oil level immediately after stopping the engine. If the engine is hot when the oil is checked, the level will appear to be overfull.

Access the oil check dipstick (1) through the right rear wheel well. Access the oil fill cap (2) by removing the cargo box. See the Service Access Panels section for details.

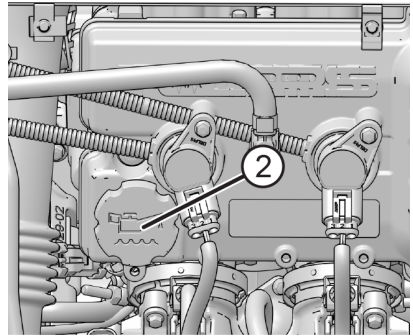
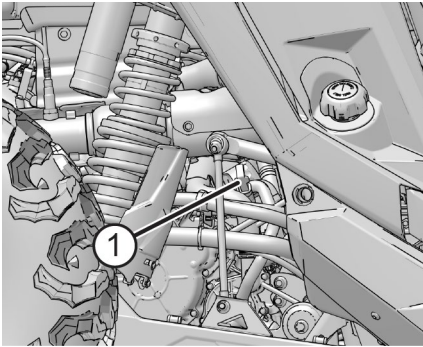

1. Position the TRACTOR on a level surface.
2. Place the transmission in PARK.
3. Start the engine. Allow the engine to idle for 30 seconds.
4. Stop the engine. Wait two (2) minutes to allow oil to drain back to the sump.
5. Remove the dipstick. Wipe it dry with a clean cloth.
6. Reinstall the dipstick completely. Remove the dipstick and check the oil level.
7. Remove the oil fill cap to add the recommended oil as needed. Maintain the oil level between the minimum and maximum marks on the dipstick. Do not overfill.
8. Reinstall the fill cap. Reinstall the dipstick.

MAINTENANCE

OIL AND FILTER CHANGE

WARNING

Spilled oil left on engine components or in the engine area may pose a fire hazard. Use shop rags to clean any spilled oil. If needed, use a non-flammable solvent on the rag to aid the cleaning process. Do not use any device such as pressurized water or air as this may disperse the oil onto engine components and could pose a fire hazard.

Always change the oil and filter at the intervals outlined in the Periodic Maintenance Chart section.

1. Position the TRACTOR on a level surface. Place the transmission in PARK.
2. Allow engine to cool down before draining oil.
3. Place a drain pan under the engine crankcase and remove the drain plug .

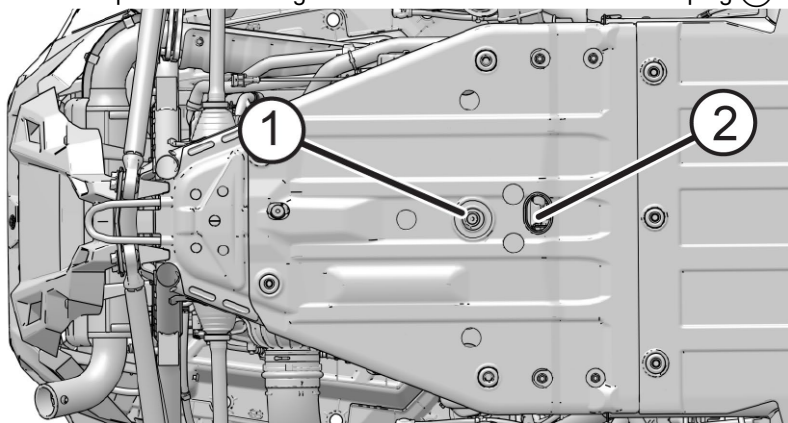

4. Access the oil filter through the access panel behind the seats. See the Service Access Panels section for details.

NOTE

The engine should be off for at least 2 minutes prior to removing the oil filter.

5. Place drain pan under filter drain  to catch any spilled oil during removal. Using the Oil Filter Wrench, turn the oil filter counterclockwise to remove it. Tip the open end of the oil filter up to minimize oil spill.

6. Clean the filter sealing surface on the engine crankcase with a clean rag and ensure the original oil filter o-ring is not stuck to the crankcase.

WARNING

Do not use a hose/pressure washer to clean up spilled oil on a TRACTOR. This may spread oil into surfaces that may get hot which may lead to a fire.

7. Lubricate the o-ring on the new oil filter with a film of clean engine oil. Check to make sure the o-ring is in good condition. Tighten to specification.

TORQUE

Oil Filter:

Turn by hand until filter O-ring contacts sealing surface, then turn an additional 3/4 turn.

8. Inspect the sealing washer on the drain plug for burrs or nicks. Replace the washer if it is damaged.
9. Reinstall the engine crankcase drain plug. Torque drain plug to specification.

TORQUE

Engine Oil Drain Plug:

16 Nm

10. Remove the cargo box. See the Service Access Panels section for details. Add engine oil through the oil fill cap (3) located on top of the engine valve cover.

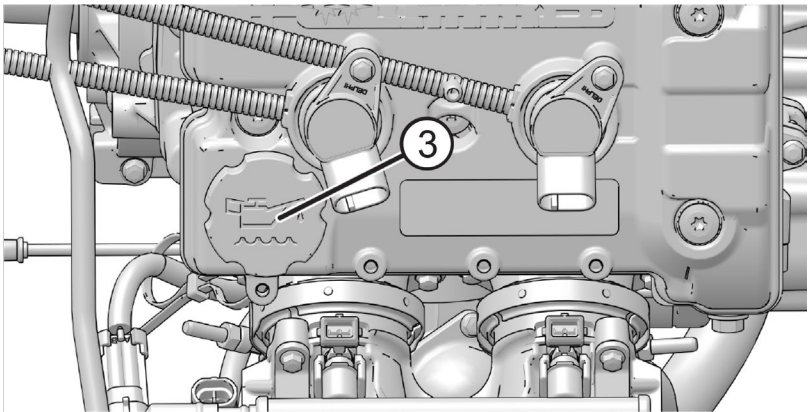

11. Fill the engine to the recommended specification.

MAINTENANCE

12. Start engine and allow it to idle for 30 seconds.
13. Stop the engine and inspect for leaks. Wait at least 15 seconds before removing the oil dipstick.
14. Unlock the dipstick lever (4). Remove the dipstick and wipe it dry with a lean rag.

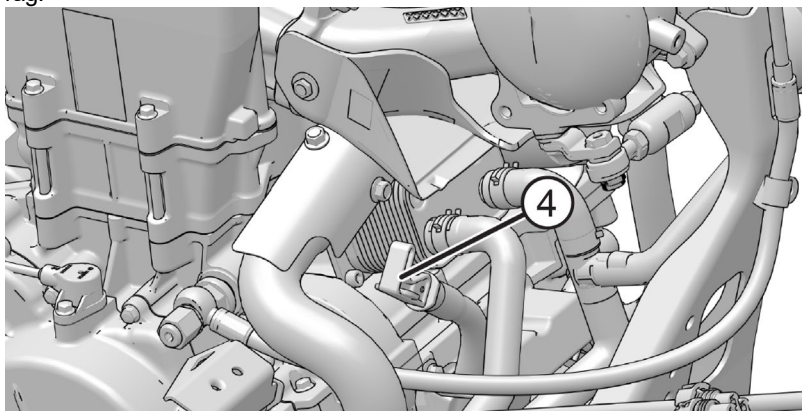

15. Reinstall the dipstick to fully seat it. Do not lock the dipstick.

NOTE

Make certain the dipstick is inserted all the way down to ensure an accurate reading.

16. Remove the dipstick and check the oil level.
17. Add the recommended oil as necessary to bring the oil level within the SAFE range (between the holes) on the dipstick. Do NOT overfill.

NOTE

A rising oil level between checks during cold weather operation can indicate contaminants such as gas or moisture collecting in the crankcase. If the oil level is over the upper mark, change the oil immediately.

18. When finished, reinstall dipstick and lock the lever.
19. Reinstall the cargo box.

TORQUE

Cargo Box Fasteners:
3.5 Nm

20. Dispose of used oil, filter, and rags properly.
21. Reinstall rear seats and access panel.

TRANSMISSION (MAIN GEARCASE)

Always check and change the fluid at the intervals outlined in the Periodic Maintenance Chart section. Refer to the Gearcase Specifications Chart section for recommended lubricants, capacities and torque specifications.

FLUID CHECK

The fill plug (1) is located on the rear of the gearcase. Maintain the fluid level at the bottom of the fill plug hole.

1. Position the TRACTOR on a level surface.
2. Remove the fill plug with a 8 mm Allen wrench.
3. Check the fluid level. The fluid should be even with the bottom of the fill plug hole.
4. If necessary, add the recommended fluid to the bottom of the fill plug hole. Do not overfill.
5. Reinstall the fill plug. Torque to specification.

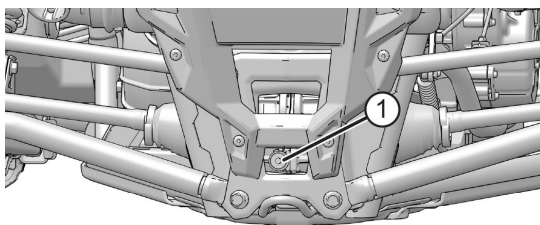

TORQUE

Fill Plug Torque:
14–19 Nm

6. Clean any fluid residue from around the fill plug.

MAINTENANCE

FLUID CHANGE

The drain plug ① is located on the bottom of the gearcase. Access the drain plug through the drain hole in the skid plate.

1. Position the TRACTOR on a level surface.
2. Remove the fill plug with a 8 mm Allen wrench.
3. Place a drain pan under the drain plug.
4. Remove the drain plug with a 8 mm Allen wrench.
5. Clean the drain plug.

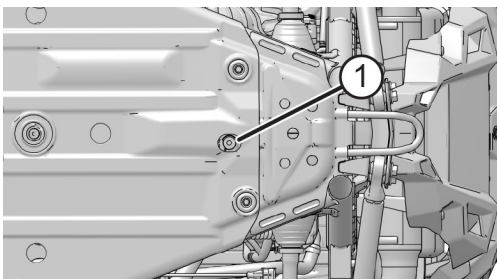

6. Reinstall the drain plug. Torque to specification.

TORQUE

Drain Plug Torque:
14–19 Nm

7. Add the recommended fluid (listed in the Gearcase Specification Chart) through the fill plug hole until the fluid is even with the bottom of the fill plug hole.
8. Reinstall the fill plug. Torque to specification.

TORQUE

Fill Plug Torque:
14–19 Nm

9. Clean any fluid residue from around the drain and fill plugs.
10. Dispose used fluid properly.

DEMAND DRIVE UNIT (FRONT GEARCASE)

Always check and change the fluid at the intervals outlined in the Periodic Maintenance Chart section. Refer to the Gearcase Specifications Chart section for recommended lubricants, capacities and torque specifications.

Fill Plug Location

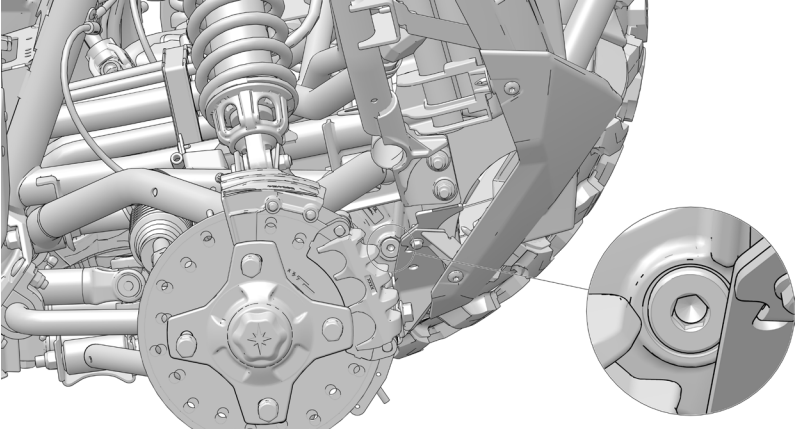

Drain Plug Location

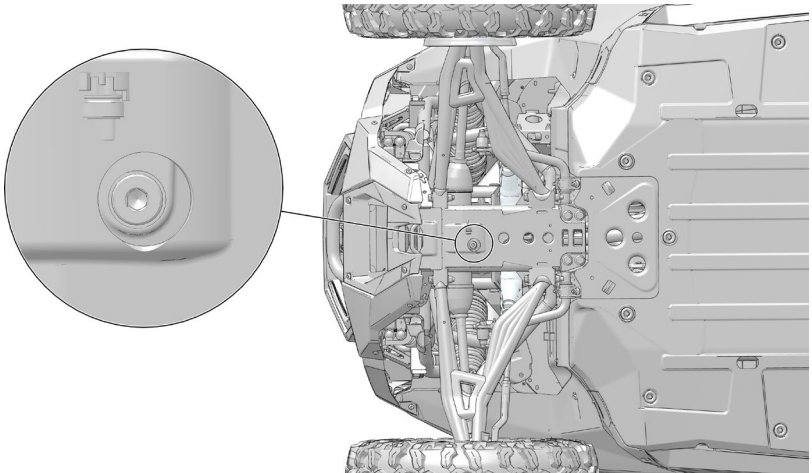

MAINTENANCE

DEMAND DRIVE FLUID CHECK

The fill plug q is located on the bottom right side of the demand drive unit. Maintain recommended fluid volume (280 ml).

1. Position the TRACTOR on a level surface.
2. Remove the fill plug with a 8 mm Allen wrench.
3. Check the fluid level. The fluid should be even with the bottom of the fill plug hole.
4. If necessary, add the recommended fluid (listed in the Gearcase Specification Chart). Do not overfill.
5. Reinstall the fill plug. Torque to specification.

TORQUE

Fill Plug Torque:
11–40 N·m

6. Clean any fluid residue from around the fill plug.

DEMAND DRIVE FLUID CHANGE VIDEO

Help Center Video

<https://www.youtube.com/watch?v=VD62swuRtaQ>

GEARCASE SPECIFICATION CHART

Use of other fluids may result in improper operation of components. See the EGIMOTORS Products section for the part numbers.

Gearcase	Lubricant	Capacity	Fill Plug Torque	Drain Plug Torque
Transmission (Main Gearcase)	AGL Gearcase Lubricant & Transmission Fluid	1800 mL	14–19 N·m	14–19 N·m
Demand Drive Unit (Front Gearcase)	Demand Drive Fluid	280 mL	11–40 N·m	11–40 N·m

SPARK PLUGS

SPARK PLUG GAP / TORQUE

Electrode Gap	Spark Plug Torque
0.7-0.8 mm	10 Nm

NOTICE

Using non-recommended spark plugs can result in serious engine damage. Always use EGIMOTORS-recommended spark plugs or their equivalent. Refer to the Specifications section for details.

Spark plug condition is indicative of engine operation. The spark plug firing end condition should be read after the engine is warmed up and the TRACTOR is driven at higher speeds. Immediately check the spark plug for correct color.

⚠ CAUTION

A hot exhaust system and engine can cause burns. Wear protective gloves when removing a spark plug for inspection.

SPARK PLUG REMOVAL AND REPLACEMENT

1. Remove the cargo box to access the spark plugs ①.

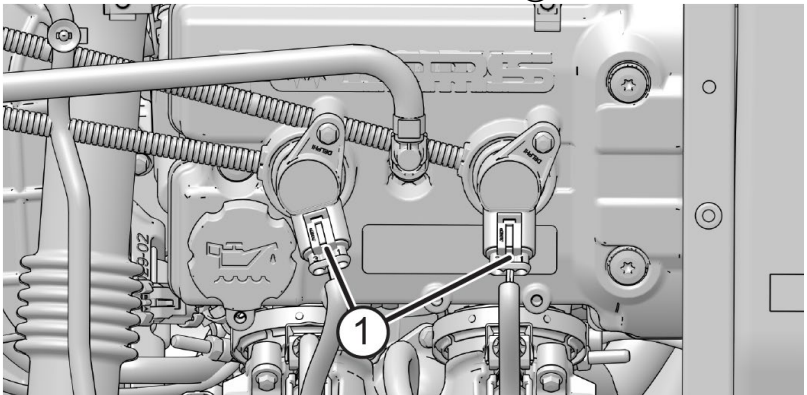

2. Clean the area around the spark plugs before removing the plugs. Unbolt the coils on the plugs.
3. Remove the coil assemblies.

MAINTENANCE

- Using the spark plug wrench provided in the tool kit, remove the plugs by rotating them counterclockwise.
- Reverse the procedure for spark plug installation. Torque to specification.

TORQUE

Spark Plug Torque:
10 Nm

TORQUE

Cargo Box Fasteners:
3.5 Nm

SPARK PLUG CONDITION

NORMAL PLUG

The normal insulator tip is gray, tan or light brown. There will be few combustion deposits. The electrodes are not burned or eroded. This indicates the proper type and heat range for the engine and the service.

NOTICE

The tip should not be white. A white insulator tip indicates overheating, caused by use of an improper spark plug or incorrect throttle body adjustments.

WET FOULED PLUG

The wet fouled insulator tip is black. A damp oil film covers the firing end. There may be a carbon layer over the entire nose. Generally, the electrodes are not worn. Fouling may be caused by excessive oil or by frequent short trips, especially in cold weather.

MAINTENANCE

PRIMARY FUSE CENTER		
LABEL	VALUE	FUNCTION
FAN	30A MCASE Fuse	Engine Cooling Fan
EPS	40A MCASE Fuse	Electronic Power Steering
AUD AMP	30A MCASE Fuse	Audio Amplifier
VREG 1	40A MCASE Fuse	Voltage Regulator (Driver)
VREG 2	40A MCASE Fuse	Voltage Regulator (Passenger)
PULSE PWR	200A ZCASE Fuse	Battery Power to EGIMOTORS Pulse and 6AWG Cable

The secondary fuse centerw is underneath the driver's side dash, above the throttle pedal.

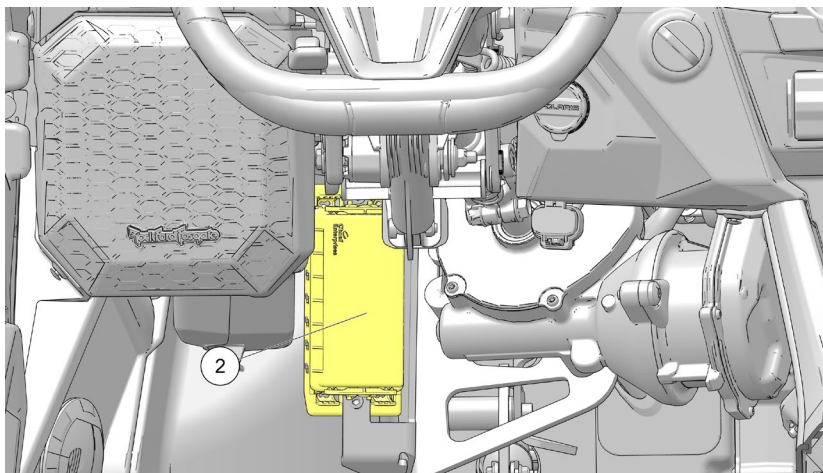

SECONDARY FUSE CENTER		
LABEL	VALUE	FUNCTION
LCAC	7.5A Fuse	Water Pump
FUEL	10A Fuse	Fuel Pump

SECONDARY FUSE CENTER		
LABEL	VALUE	FUNCTION
TERM BLK	10A Fuse	Terminal Block Accessory
INST ACCY	7.5A Fuse	Diagnostic Accessory, Interior LED Light, Display Accessory (optional)
PWR PT 1	10A Fuse	12V Socket (in front of gear selector)
INST UNSW	7.5A Fuse	Display (optional), Gauge, Diagnostic
LIGHTS	7.5A Fuse	Switched power to Headlights, Taillights, Accent Lights (optional), Brake Lights
LIGHTS 2	10A Fuse	B+ power to Headlights, Fang Lights, Exterior Lights
CHASSIS	7.5A Fuse	AWD Switch Light, Oxygen Sensor Heater, EPS Wake-Up, TRACTOR Speed Sensor, Seat Belt Switch, SCM Wake-Up (optional), SCM Mode Switch (optional), AWD Coil, Gauge, Waste Gate
EFI	10A Fuse	Accessory Relay Coil, ECM Wake-Up, Pump Relay Coil, Chassis Relay Coil, Start Relay Coil, EFI Relay Coil, Injectors, SCM Relay Coil (optional), Lights Relay Coil, Ignition Coil, Starter Solenoid Coil, Brake Relay Coil
COIL	7.5A Fuse	Coil on Plug
CHARGE	15A Fuse	CHARGE
DYNAMIX Models		
SCM	7.5A Fuse	Shock Control Module
SHOCK	7.5A Fuse	Shock Power
SUB*	40A Fuse	Audio Subwoofer

MAINTENANCE

*For TRACTORs equipped with subwoofers, the fuses are located underneath the front storage compartment above the center console. Open the storage compartment and unlatch the four clips holding the storage tray in place to access the fuses.

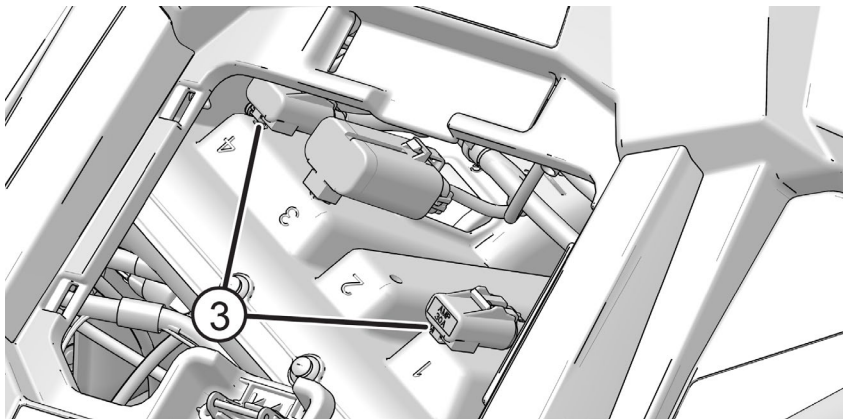

COOLING SYSTEM

 **CAUTION**

Escaping steam can cause burns. Never remove the pressure cap while the engine is warm or hot. Always allow the engine to cool before removing the pressure cap.

The engine coolant level is maintained by a remote pressurized tank system. The remote pressurized tank is connected to both radiators and provides a single pressure cap and fill point for the TRACTOR.

NOTICE

The cooling system can cause audible liquid flowing noises as the TRACTOR cools down after operation. This is considered normal for the TRACTOR.

The pressure tank is designed to contain a volume of air above the coolant level. As coolant operating temperature increases the coolant level in the pressure tank will rise and push out air past the pressure cap. As the engine coolant temperature decreases the coolant level in the pressure tank will lower and draw air back into the tank through the pressure cap.

NOTICE

Some coolant level drop on new TRACTORS is normal as the system is purging itself of trapped air. Observe coolant levels and maintain cold coolant level as recommended by adding coolant to the pressure tank.

MAINTENANCE

RADIATOR COOLANT LEVEL / CHANGING COOLANT

The changing coolant procedure is required only if the cooling system has been drained for maintenance and/or repair. Ensure TRACTOR is parked on a level surface before servicing.

CAUTION

Escaping steam can cause burns. Never remove the pressure cap while the engine is warm or hot. Always allow the engine to cool before removing the pressure cap.

1. If only needing to check coolant level, there is a view ① from driver's side rear fender. A flashlight may be needed. The coolant level can also be viewed by removing the cargo box.

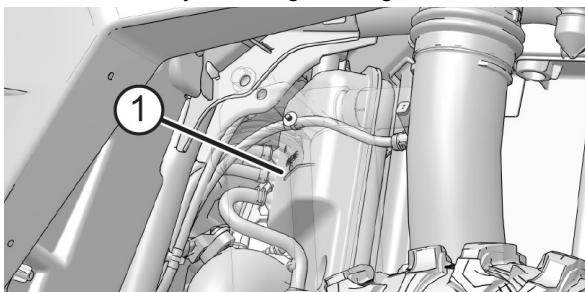

TIP

Ensure engine has cooled off prior to checking.

2. To add coolant, begin by removing bottle access cover ② in rear of TRACTOR.

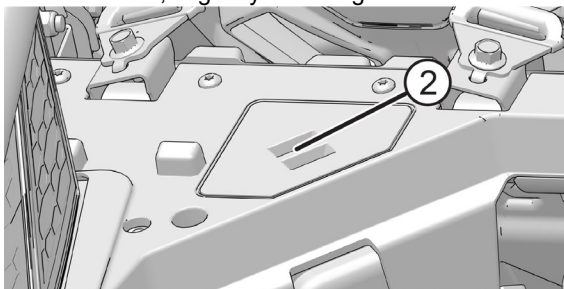

3. Slowly remove the radiator pressure cap ③.

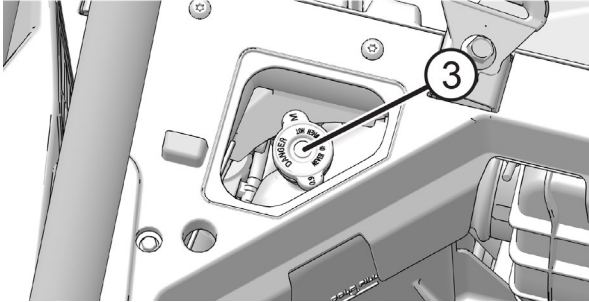

4. Remove the pressure cap and use a funnel to add coolant as needed. Maintain the coolant level within one 2.5 cm of the cold fill mark on the side of the pressure tank (only when the fluid has cooled, if after operation).
5. Reinstall the pressure cap and the bottle access cover.

TIP

Use of a non-standard pressure cap will not allow the recovery system to function properly. Your authorized dealer can provide the correct replacement part.

TIP

If coolant must be added often, or if the pressure tank runs completely dry, there may be a leak in the system. Your authorized dealer can inspect the cooling system.

MAINTENANCE

ADDING OR CHANGING COOLANT

EGIMOTORS recommends the use of EGIMOTORS Antifreeze 50/50 Premix. This antifreeze is already premixed and ready to use. Do not dilute with water. See the EGIMOTORS Products section for the part numbers.

To ensure that the coolant maintains its ability to protect the engine, we recommend that the system be completely drained every five (5) years and fresh Antifreeze 50/50 Premix added.

Any time the cooling system has been drained for maintenance or repair, replace the coolant with fresh Antifreeze 50/50 Premix.

RADIATORS AND COOLING FAN

Always check and clean the screens and radiator fins at the intervals outlined in the Periodic Maintenance Chart section. Do not obstruct or deflect air flow through the radiators by installing unauthorized accessories in front of the radiators or behind the cooling fan. Interference with radiator air flow can lead to overheating and consequent engine damage.

NOTICE

Washing the TRACTOR with a high-pressure hose could damage radiator fins and impair a radiator's effectiveness. Using a high-pressure system is not recommended.

EGIMOTORS VARIABLE TRANSMISSION (PVT) SYSTEM

WARNING

Failure to comply with the instructions in this warning can result in severe injury or death.

Do not modify any component of the PVT system. Doing so may reduce its strength so that a failure may occur at a high speed. The PVT system has been precision balanced. Any modification will cause the system to be out of balance, creating vibration and additional loads on components.

The PVT system rotates at high speeds, creating large amounts of force on clutch components. As the owner, you have the following responsibilities for your own safety and the safety of others:

- Always follow all recommended maintenance procedures. Always look for and remove debris inside and around the clutch and vent system when replacing the belt.
- See your dealer or other qualified service person as recommended in the owner's manual and on safety labels.
- This PVT system is intended for use on EGIMOTORS products only. Do not install it in any other product.
- Always make sure the PVT housing is securely in place during operation.

Belt slip is responsible for creating excessive heat that destroys belts, wears clutch components and causes outer clutch covers to fail. Switch to low range while operating at slower speeds to extend the life of the PVT components (belt, cover, etc.).

MAINTENANCE

BELT REMOVAL AND REPLACEMENT

If a belt fails, always clean any debris from the outlet duct and from the clutch and engine compartments when replacing the belt.

WARNING

Failure to remove ALL debris when replacing the belt could result in TRACTOR damage, loss of control and severe injury or death.

TIP

- Wiggling and rocking the cover will help it move around the bolts on the clutch towers.
- Make sure the clutch cover bolts are not catching on other parts.
- Rotating the drive clutch slightly by hand can provide more clearance in some cases.
- For easiest removal, make sure the TRACTOR is sitting on the ground at normal ride height or lower, which will provide more clearance between the cover and the shock absorber. Turning the drive clutch slightly by hand can also help provide more room for removal.
- If reinstalling the belt, reference the print on the belt to reinstall in the same direction.

NOTICE

Drive belt maintenance should only be performed after the TRACTOR has completely cooled.

1. Allow hot components to cool before performing this procedure.

NOTE

If the TRACTOR is on solid ground, removal of the left rear wheel or shock is not necessary for belt replacement. If the TRACTOR is on a lift, the shock must be removed in order to remove the clutch cover.

2. Loosen the clamp ① retaining the PVT inlet duct to the outer clutch cover.

3. Remove the fourteen (14) clutch cover screws ②.

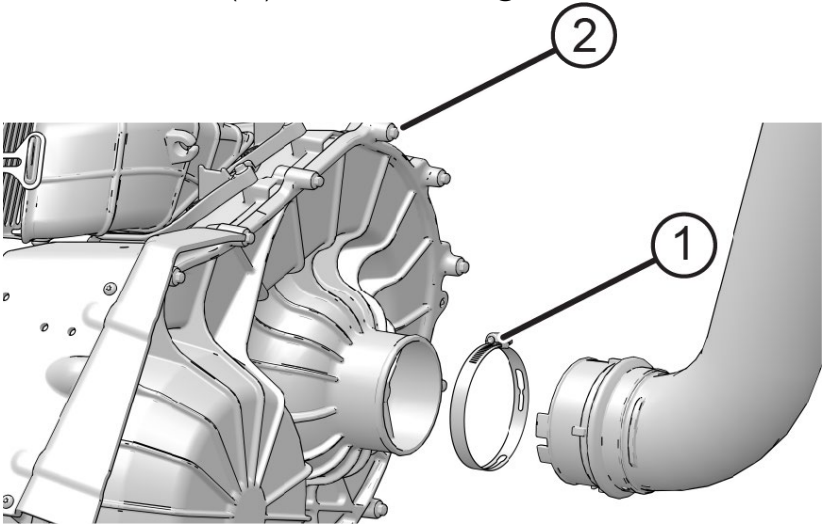

4. Maneuver the outer clutch cover outward to access the drive belt.
5. Mark the drive belt direction of rotation so that it can be installed in the same direction.
6. Insert the clutch spreader tool ③ into the driven clutch. The tool is provided in the tool kit.

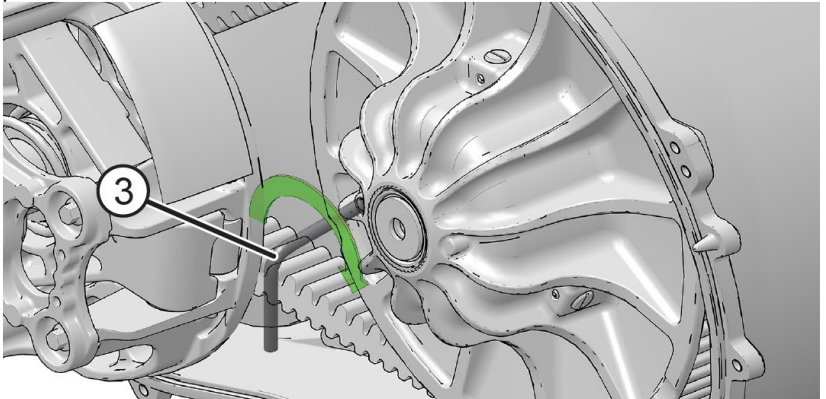

7. Turn the tool clockwise to open the sheaves on the driven clutch.
8. Walk the belt out of the driven and drive clutch. Remove the belt.

MAINTENANCE

9. Remove **ALL** debris wrapped in and around the PVT system.
10. Remove **ALL** debris from the entire clutch air duct passage.
11. Check for signs of damage to seals on the transmission and engine. If any seals appear to be damaged, your TRACTOR requires prompt service. Your EGIMOTORS dealer can assist.
12. With the clutch spreader tool installed, loop the belt over the drive clutch and over part of the driven clutch. Be sure to install belt in the direction previously marked.
13. Rotate the driven clutch and walk the belt into the clutch.
14. Remove the clutch spreader tool from the driven clutch.
15. Rotate / spin the driven clutch and belt approximately 5-7 times to properly seat the belt in the driven clutch.
16. Install the outer clutch cover and fourteen fasteners q . Torque fasteners to specification.

TORQUE

Outer Clutch Cover Fasteners:
6 N·m

17. Reattach the PVT inlet duct to the outer clutch cover (and fasten with the clamp).

TORQUE

PVT Intake Hose Clamp:
3 N·m

TIP

Belt slip is responsible for creating excessive heat that wears belts, clutch components and causes outer clutch covers to fail. Switch to low range while operating at slower speeds to extend the life of the PVT components (belt, cover, etc.). Prolonged operation with heavy loads or at high speeds can shorten belt life.

PVT DRYING

There may be some instances when water is accidentally ingested into the PVT system. Use the following instructions to dry it out before operating.

NOTICE

When washing the TRACTOR, always avoid spraying water directly toward the PVT intake duct. See the Washing the TRACTOR section for details.

1. Remove the clutch cover drain plug.
2. Allow the water to drain. Reinstall the drain plug.
3. Place the transmission in PARK. Apply the brakes.
4. Start the engine.
5. Apply varying throttle for 10-15 seconds to expel the moisture and air-dry the belt and clutches. Do not hold the throttle wide open for more than 10 seconds.
6. Allow the engine RPM to settle to idle speed. Apply the brakes. Shift the transmission to the lowest available range.
7. Test for belt slippage. If the belt slips, repeat the process.
8. Your TRACTOR requires service as soon as possible. Your EGIMOTORS dealer or authorized person can assist.

FILTER SYSTEMS

INTAKE PRE-FILTERS

The clutch air intake ① is located on the left side of the TRACTOR. The engine intake pre-filter ② is located on the right side of the TRACTOR.

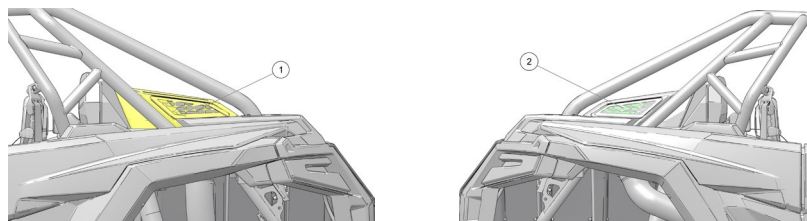

Inspect the engine pre-filter before each use of the TRACTOR to ensure adequate air flow. If necessary, remove the pre-filter and clean with soapy water. Dry with low pressure compressed air.

Periodically inspect the clutch (PVT) air intake for debris and clean as needed to ensure adequate air flow.

TIP

When washing the TRACTOR, always avoid spraying water directly toward the PVT intake. If water is sprayed into the PVT intake, follow the procedures in the PVT Drying section. See the Washing the TRACTOR section for recommended washing procedures.

AIR FILTER

WARNING

Be sure to replace all TRACTOR components as before once finished servicing the air filter. Improper thermal protection creates a fire hazard and can lead to injury or death.

Always change the air filter at the intervals outlined in the Periodic Maintenance Chart.

1. Remove seats. See the Seat Removal section for details.
2. Remove the close-off panel between the seats.
3. Clean all dirt and debris from the air box area.
4. Unlatch the five (5) air box cover clips  and carefully remove the air box cover.

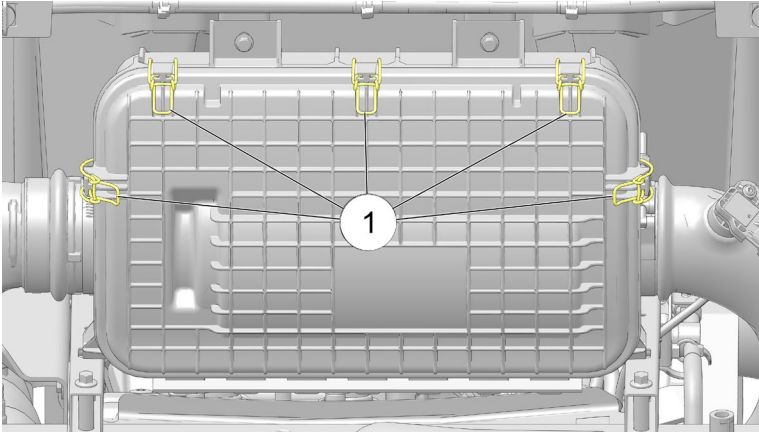

MAINTENANCE

5. Inspect the air filter ② and air box for dirt, debris or water.

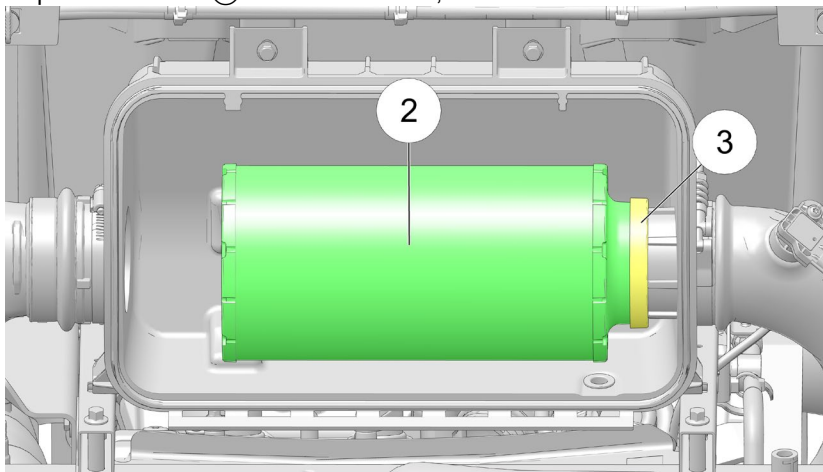

6. To remove the filter, slide the filter toward the passenger's side of the TRACTOR.
7. With the filter removed, clean the intake tube and air box thoroughly. Wipe well with a clean, dry cloth.

NOTICE

Dirt or debris in the intake tube could result in severe engine damage. Always clean all dirt and debris from the intake tube before installing the filter.

8. Reinstall the air filter (if clean) or install a new air filter (if soiled). Do not attempt to clean the air filter.

NOTICE

Use of a non-EGIMOTORS-approved air filter may cause engine damage. Always use a EGIMOTORS-approved replacement filter. Replacement filters are available at your EGIMOTORS dealer.

9. Make sure that there are no gaps between the filter, the filter ring ③ and the stop on the intake tube.
10. Reinstall the air box cover and ensure the alignment tabs are properly positioned.
11. Secure the five (5) cover clips.
12. Reinstall the close-off panel.
13. Reinstall seats.

SPARK ARRESTOR

WARNING

- Never operate the TRACTOR without the spark arrestor.
- Remove any combustible materials from the area.

Failure to heed the following warnings while servicing the spark arrestor could result in serious injury or death.

- Never run the engine in an enclosed area. Exhaust contains poisonous carbon monoxide gas that can cause loss of consciousness or death in a very short time.
- Do NOT perform service on the spark arrestor while the system is HOT. Exhaust system temperatures can reach extreme temperatures. Allow components to cool sufficiently before proceeding.
- Do not stand behind or in front of the TRACTOR while purging the exhaust system.
- Never go under the TRACTOR while it is inclined.
- Wear eye protection and gloves while servicing.

Periodically clean the spark arrestor to remove accumulated carbon. A plugged spark arrestor will affect engine performance. Clean daily when driving in mud and water. Replace a cracked or damaged arrestor before operating.

1. Turn off the engine and allow the exhaust system to cool.
2. Remove the arrestor retaining bolt and nut.
3. Remove the arrestor from the end of the muffler.
4. Use a non-synthetic brush to clean the arrestor screen. A synthetic brush may melt if components are warm. If necessary, blow debris from the screen with compressed air.
5. Inspect the screen for wear and damage. Replace a worn or damaged screen.
6. Reinstall the arrestor. Torque bolt to specification.

TORQUE

Spark Arrestor Retaining Bolt:

11 N·m

BRAKES

WARNING

Operating the TRACTOR with a spongy brake pedal can result in loss of braking, which could cause an accident resulting in severe injury or death. Never operate the TRACTOR with a spongy-feeling brake pedal.

The front and rear brakes are hydraulic disc type brakes activated by the brake pedal.

CAUTION

Brake discs can become extremely hot after operation. Allow the discs to cool before performing maintenance to prevent risk of burns.

Always check brake pedal travel and the brake fluid reservoir level before each use of the TRACTOR. When applied, the brake pedal should feel firm. Any sponginess would indicate a possible fluid leak or low brake fluid level, which must be corrected before riding. See the Brake Fluid section for further details.

If you discover any irregularities in brake system operation, including excessive pedal travel, contact your dealer for proper diagnosis and repairs.

BRAKE INSPECTION

1. Check the brake system for fluid leaks.
2. Check the brake pedal for excessive travel or a spongy feel.
3. Check the friction pads for wear, damage and looseness.
4. Check brake discs for signs of cracks, excessive corrosion, warping or other damage. Clean any grease using an approved brake cleaner or alcohol.
5. Inspect the brake disc pad wear surface  for excessive wear. Change pads when worn to 0.762 mm.

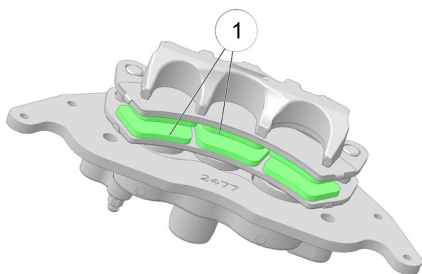

BRAKE FLUID

WARNING

After opening a bottle of brake fluid, always discard any unused portion. Never store or use a partial bottle. Brake fluid is hygroscopic, meaning it rapidly absorbs moisture from the air. The moisture causes the boiling temperature of the brake fluid to drop, which can lead to early brake fade and the possibility of accident or severe injury.

Inspect the level of the brake fluid before each operation. If the fluid level is low add DOT 4 brake fluid only. See the EGIMOTORS Products section for the part numbers.

Change the brake fluid every two years and any time the fluid becomes contaminated, the fluid level is below the minimum, or if the type and brand of the fluid in the reservoir are unknown. Access the brake fluid reservoir through the left front wheel well.

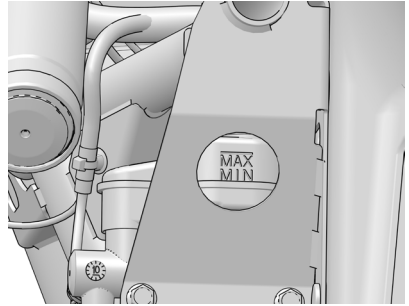

1. Position the TRACTOR on a level surface.
2. Place the transmission in PARK.
3. View the brake fluid level in the reservoir, located in the front driver-side wheel well. The level should be between the maximum and minimum level lines.
4. If the fluid level is lower than the lower level line, add brake fluid to the upper line.

WARNING

Do not overfill the brake system reservoir. Overfilling can cause pressure build-up leading to brake drag, system degradation, and brake system failure.

5. Apply the brake forcefully for a few seconds and check for fluid leakage around the fittings.

SUSPENSION SYSTEM

FRONT / REAR SHOCK COMPRESSION ADJUSTMENT (IF APPLICABLE)

 **WARNING**

Be advised that the shocks contain nitrogen at high pressure. Damaged shocks could cause injury if not replaced or addressed promptly by qualified personnel.

 **CAUTION**

Keep other individuals away from the TRACTOR when adjusting the shocks. Boarding the TRACTOR creates sudden shock compression, which can cause pinched fingers during maintenance.

The compression damping clicker knob is located at the top of the shock reservoir. When the knob is turned fully clockwise, the damping is in the fully closed position.

1. Turn the clicker clockwise to increase compression damping.
2. Turn the clicker counter-clockwise to decrease compression damping.

SETTING	COMPRESSION DAMPING
Softest	Position 1
Factory	Position 2
Firmer	Position 3

FRONT / REAR SPRING PRELOAD ADJUSTMENT

The factory setting is appropriate for nearly all riding conditions. If desired, the suspension may be adjusted to maintain TRACTOR clearance height when carrying loads. Adjusting the suspension may change TRACTOR handling.

IMPORTANT

The distance between the main preload ring (top ring) and the cross-over rings (middle rings) should be constant. If you move the main preload ring, you will need to move the cross-over rings an equal amount. The cross-over rings need to be locked tight after any adjustment is made. To lock the cross-over rings, take a punch and hammer to hit each side so the rings jam together. If the cross-over rings are not locked down tight, damage to the shock may occur.

To adjust the preload, do the following:

1. Elevate the TRACTOR to allow the suspension to fully extend.
2. Turn the adjusting ring to the left to add preload. Turn the adjusting ring to the right to remove preload.

Uneven adjustment may cause poor handling of the TRACTOR. Always adjust both the left and right spring preloads equally or have your EGIMOTORS dealer or qualified person perform the adjustments.

SPRING PRELOAD ADJUSTMENTS		
RZR PRO XP		
If weight is added to the center of the unit, split the preload setting accordingly between the front and the rear	+14 mm per 45.4 kg added to front	MAX: 25 mm
	+11 mm per 5.4 kg) added to rear	MAX: 25 mm
RZR PRO XP 4		
If weight is added to the center of the unit, split the preload setting accordingly between the front and the rear	+13 mm per 45.4 kg added to front	MAX: 25 mm
	+13 mm per 45.4 kg added to rear	MAX: 25 mm

MAINTENANCE

PRELOAD SETTINGS

Adjusting preload settings can alter TRACTOR handling.

IMPORTANT

Never exceed the MAX allowable preload when adjusting the suspension. Damage to the suspension system may occur if the MAX allowable preload is exceeded.

RZR PRO XP		FACTORY DEFAULT PRELOAD SETTINGS	
	Measurements*	Fox® Dynamix	Fox® QS3®
Front Shocks	①	8.89 cm	6.20 cm
	②	6.50 cm	5.56 cm
Rear Shocks	①	14.12cm	13.34cm
	②	19.53cm	19.53cm

*See the images in the Front / Rear Spring Preload Adjustment section to view corresponding measurements

RZR PRO XP 4		FACTORY DEFAULT PRELOAD SETTINGS	
	Measurements*	Fox® Dynamix	Fox® QS3®
Front Shocks	①	5.08 cm	2.06 cm
	②	7.32 cm	7.14 cm
Rear Shocks	①	15.90cm	14.94cm
	②	17.14cm	19.20cm

*See the images in the Front / Rear Spring Preload Adjustment section to view corresponding measurements

FOX® DYNAMIX SHOCKS (IF EQUIPPED)

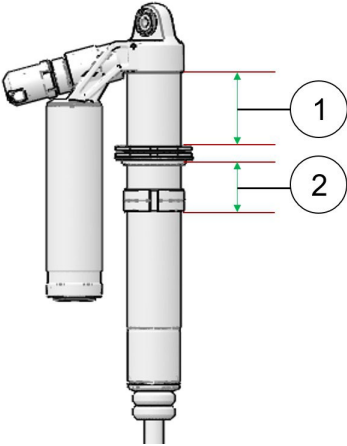
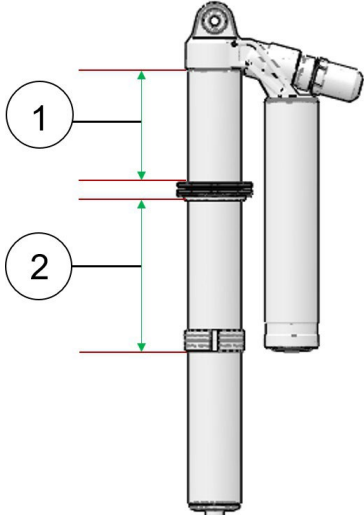
SHOCK LOCATION	MEASUREMENT*
Front Shock	 <p>The diagram shows a front FOX Dynamix shock. Two measurement points are indicated with green double-headed arrows and red horizontal lines. Measurement 1 is the distance from the top of the shock body to the top of the lower leg. Measurement 2 is the distance from the top of the lower leg to the bottom of the shock body.</p>
Rear Shock	 <p>The diagram shows a rear FOX Dynamix shock. Two measurement points are indicated with green double-headed arrows and red horizontal lines. Measurement 1 is the distance from the top of the shock body to the top of the lower leg. Measurement 2 is the distance from the top of the lower leg to the bottom of the shock body.</p>

MAINTENANCE

FOX® QS3® SHOCKS (IF EQUIPPED)

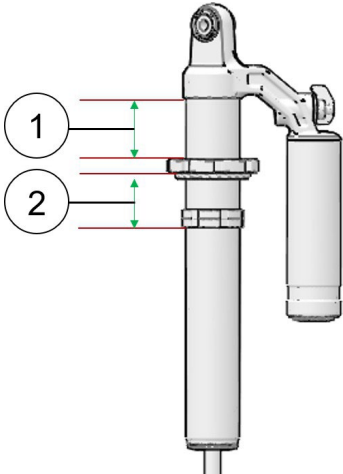
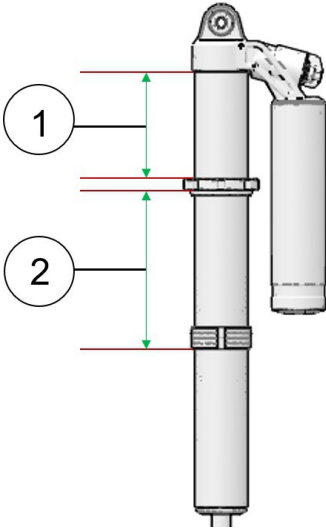
SHOCK LOCATION	MEASUREMENT*
Front Shock	 <p>The diagram shows a front FOX QS3 shock. Two measurement points are indicated with green double-headed arrows and red horizontal lines. Point 1 is the distance from the top mounting eye to the center of the shock body. Point 2 is the distance from the center of the shock body to the bottom mounting eye.</p>
Rear Shock	 <p>The diagram shows a rear FOX QS3 shock. Two measurement points are indicated with green double-headed arrows and red horizontal lines. Point 1 is the distance from the top mounting eye to the center of the shock body. Point 2 is the distance from the center of the shock body to the bottom mounting eye.</p>

TIRES

 WARNING

Improper tire maintenance can lead to loss of control and an accident, which could result in serious injury or death. To reduce your risk of injury:

- Maintain EGIMOTORS recommended tire pressure. Check pressure before operating. Even if your TRACTOR has only been driven a short distance, the tire pressure readings can be higher.
- Make sure tire pressure is even across all four tires.
- Only use the size and type of tires specified for this TRACTOR.
- Do not operate your TRACTOR with worn or damaged tires.
- Always follow your tire manufacturer's instructions for maintenance

 WARNING

Improperly installed wheels can separate from the TRACTOR, which can result in serious injury or death. Improper wheel installation can also adversely affect tire wear and TRACTOR handling. Always ensure that all wheel nuts are tightened to torque specification. Re-check wheel nut torque 40 kilometers after installation.

 WARNING

Improperly jacking or supporting the TRACTOR can result in the TRACTOR falling or tipping, which can lead to serious injury or death. When elevating TRACTOR:

- Move TRACTOR to a firm level surface.
- Shift to PARK (P).
- Do not leave engine running.
- Prevent the TRACTOR from moving by chocking the wheels. A chock is a wedge or wheel stop that is designed to keep the TRACTOR from moving forward or backward and falling off the jack. If jacking the FRONT of the TRACTOR, then chock front and rear sides of both REAR tires. If jacking the REAR of the TRACTOR, then chock front and rear sides of both FRONT tires.
- Keep bystanders away and make sure no occupants or cargo are still in the TRACTOR.
- Use a jack designed for a high ground clearance off-road TRACTOR (such as the EGIMOTORS High-Lifting Jack).
- Follow the jack manufacturer's instructions.
- Do not place any object above or under a jack.
- After lifting TRACTOR with a jack, never place any part of your body under the TRACTOR without first properly blocking TRACTOR using designated support points.

MAINTENANCE

TIRE TREAD DEPTH

Always replace tires when tread depth is worn to 5 mm or less. *Image is for reference only. Your model might differ slightly.*

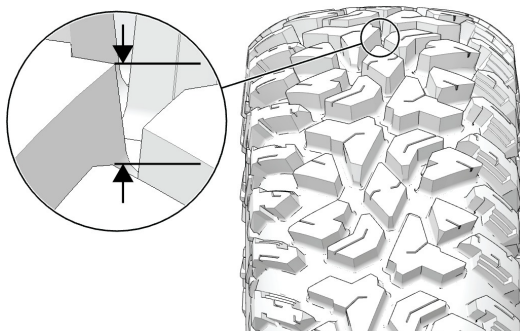

TIRE ROTATION

Tire rotation is recommended for every 800-km interval. Perform tire rotation on the TRACTOR by the strategy as shown.

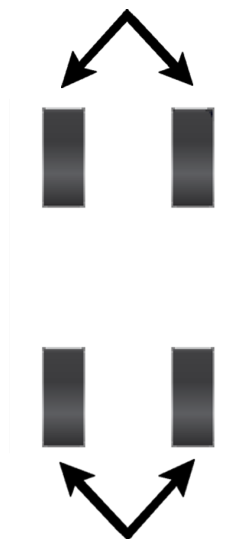

AXLE AND WHEEL NUT TORQUE SPECIFICATIONS

Inspect the following items occasionally for tightness, and if they've been loosened for maintenance service. *Do not lubricate the stud or the lug nut.*

Lug Nut (Aluminum Wheels)	Front and Rear	162.7 Nm
Hub Retaining Nut	Front and Rear	244 Nm

WHEEL REMOVAL

1. Park the TRACTOR on a flat, level surface.
2. Make sure the TRACTOR is in PARK and remove the key.
3. Loosen the wheel lug nuts before the TRACTOR is off the ground, but do NOT remove.
4. Safely elevate the TRACTOR.
5. Remove the wheel lug nuts.
6. Remove the wheel.

WHEEL INSTALLATION

 **WARNING**

Improperly installed wheels can adversely affect tire wear and TRACTOR handling, which can result in serious injury or death. Always ensure that all nuts are torqued to specification. Do not service axle nuts that have a cotter pin installed. Your EGIMOTORS dealer or other qualified person can assist.

1. Place the transmission in PARK.
2. Place the wheel in the correct position on the wheel hub. Be sure the valve stem q is toward the outside and rotation arrows on the tire point toward forward rotation.
3. Attach the wheel nuts and finger tighten.
4. Carefully lower the TRACTOR to the ground.
5. Torque the wheel nuts to specification. See the Axle and Wheel Nut Torque Specifications section for details.

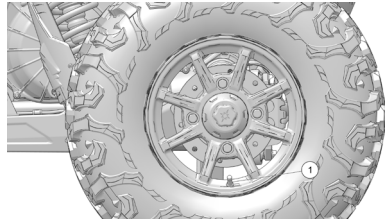

Right Rear Wheel
(type varies by model)

LIGHTS

Headlight and taillight lenses become dirty during normal operation. Clean all lights frequently to ensure a clear field of vision as well as visibility to other TRACTORS.

TIP

LED LAMPS

If an LED headlamp appears to have moisture or fogging *inside* the lens, disconnect the wiring harness from the headlamp(s) for a few days to allow the moisture to clear out.

TAILLIGHT / BRAKE LIGHT REPLACEMENT

If a taillight becomes damaged or inoperable, the entire taillight assembly must be replaced.

HEADLIGHT REPLACEMENT

If a headlight becomes damaged or inoperable, the entire headlight assembly must be replaced. Do not operate this TRACTOR at night or in low light conditions until the headlight is replaced. Always make sure lights are adjusted properly for best visibility.

HEADLIGHT BEAM ADJUSTMENT

The headlight beam can be adjusted slightly upward or downward and to the left or right. *Below image is for reference only. Your model might differ slightly.*

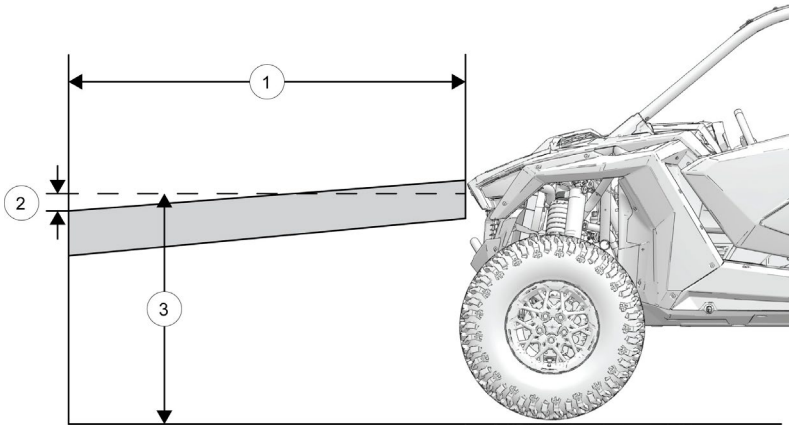

NOTE

For information on accessing headlight adjustment screws, please refer to the Service Manual or contact your EGIMOTORS dealer.

1. Position the TRACTOR on a level surface. The headlight should be approximately 7.6 m (1) from a wall.
2. Measure the distance from the floor to the center of the headlight (2) and make a mark on the wall at the same height.
3. Apply the brakes. Start the engine. Place the transmission in PARK. Turn the headlights on.

MAINTENANCE

4. Include the weight of a rider on the seat while performing this step. Observe the headlight aim. As a starting point, the most intense part of the headlight beam should be 5 cm (2) below the mark on the wall. Adjust to operator preference.
5. Tighten or loosen the two (2) headlight screws (4) to adjust the beam upward or downward or to the left or right.

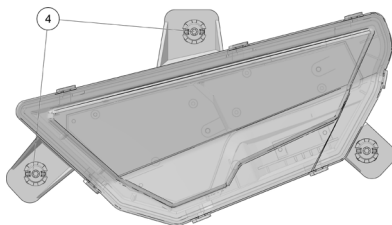

TRACTOR IMMERSION

NOTICE

If your TRACTOR becomes immersed, major engine damage can result if the machine is not thoroughly inspected. Take the TRACTOR in for service before starting the engine. Your EGIMOTORS dealer can provide this service.

If it's impossible to take your TRACTOR to a dealer before starting it, follow the steps outlined below.

1. Move the TRACTOR to dry land.
2. Check the air box. See the Air Filter section for details. If water is present, dry the air box and replace the filter with a new filter.
3. Remove the fuse/relay center cover. See the Fuse/Relay Center section for details. Allow any moisture to dry, then reinstall the cover.
4. Dry the spark plug wells with a clean cloth, then remove the spark plugs.
5. Turn the engine over several times to expel any water from the engine cylinders.
6. Dry the spark plugs and reinstall them, or install new plugs.
7. Attempt to start the engine. If necessary, repeat the drying procedure.
8. Take the TRACTOR in for service as soon as possible, whether you succeed in starting it or not. Your EGIMOTORS dealer can provide the required service.
9. If water has been ingested into the PVT follow the steps in the EGIMOTORS Variable Transmission (PVT) System section for drying procedures.

STEERING WHEEL INSPECTION

Check the steering wheel for specified freeplay and smooth operation at the intervals outlined in the Periodic Maintenance Chart.

1. Position the TRACTOR on level ground.
2. Lightly turn the steering wheel left and right.
3. There should be 20-25 mm of freeplay.
4. If there is excessive freeplay or strange noises, or if the steering feels rough or "catchy," have the steering system inspected by an authorized EGIMOTORS dealer or other qualified personnel.

BATTERY

WARNING

Improperly connecting or disconnecting battery cables can result in an explosion and cause serious injury or death. When removing the battery, always disconnect the negative (black) cable first. When reinstalling the battery, always connect the negative (black) cable last.

Your TRACTOR has a low-maintenance battery. Always keep battery terminals and connections free of corrosion. If cleaning is necessary, remove the corrosion with a stiff wire brush. Wash with a solution of one tablespoon baking soda and one cup water. Rinse well with tap water and dry off with clean shop towels. Coat the terminals with dielectric grease or petroleum jelly.

NOTE

If more amperage is required for high electrical loads, an additional battery can be added.

BATTERY REMOVAL

1. Ensure the key switch is set to OFF position before removing the battery.
2. Remove the driver's seat. See the Seats section for details.
3. Disconnect the black (negative) battery cable. Secure away from the battery terminals.
4. Disconnect the red (positive) battery cable.
5. Remove the battery hold-down strap.
6. Lift the battery out of the TRACTOR.

BATTERY INSTALLATION

Using a new battery that has not been fully charged can damage the battery and result in a shorter life. It can also hinder TRACTOR performance. Follow the instructions in the Battery Charging section before installing the battery.

1. Ensure that the battery is fully charged.
2. Place the battery in the battery holder.
3. Coat the terminals with dielectric grease or petroleum jelly.
4. Secure the battery hold-down strap.
5. Connect and tighten the red (positive) cable first.
6. Connect and tighten the black (negative) cable last.

7. Verify that cables are properly routed.
8. Reinstall the seat.

BATTERY MAINTENANCE AND CHARGING

WARNING

An overheated battery may explode, causing severe injury or death. Always watch charging times carefully. Stop charging if the battery becomes very warm to the touch. Allow it to cool before resuming charging.

WARNING

The sealed battery is already filled with electrolyte and has been sealed and *fully charged* at the factory. *Never* pry the sealing strip off or add any other fluid to this battery. It contains sulfuric acid. Serious burns can result from contact with skin, eyes, or clothing.

The single most important thing about maintaining a sealed battery is to keep it fully charged. Check the battery voltage with a voltmeter or multimeter. A fully charged battery will register 12.8 V or higher. If the voltage falls below 12.5V, charge it immediately, or the battery runs the risk of sulfation and reduced battery life.

This TRACTOR is equipped with a TRACTOR battery charge port located on the dash. This allows the operator to charge the TRACTOR battery without needing to access the battery under the driver's seat.

If you do not drive the TRACTOR for more than TWO WEEKS, EGIMOTORS recommends using a BatteryMINDER® 2012 AGM - 2 AMP charger (PN 2830438), which can be ordered through your dealer.



If you plan to store the TRACTOR for ONE MONTH or longer, remove the battery from the TRACTOR, then store the battery in a cool and dry location. Continue to maintain the battery with the BatteryMINDER® 2012 AGM - 2 AMP charger.

When using an automatic charger other than a BatteryMINDER® 2012-AGM - 2 AMP charger, refer to the charger manufacturer's instructions for recharging.

MAINTENANCE

USING A CONSTANT CURRENT CHARGER

If you are using a **constant current charger** (instead of BatteryMINDer® 2012 AGM - 2 AMP charger), use the guidelines below. Always verify battery condition before and 1-2 hours after the end of charging.

State of Charge	Voltage (DC)	Action	Charge Time*
100%	12.8-13.0 volts	None, check monthly	None required
75%-100%	12.6-12.8 volts	May need slight charge, if no charge given, check in 2 weeks	3-6 hours
50%-75%	12.3-12.6 volts	Needs charge	5-11 hours
25%-50%	12.0-12.3 volts	Needs charge	At least 13 hours
0%-25%	12.0 volts or less	Needs charge	At least 20 hours

* Using AGM specific charger at standard amps specified on top of battery

CLEANING AND STORAGE

WASHING THE TRACTOR

Keeping your EGIMOTORS TRACTOR clean will not only improve its appearance but it can also extend the life of various components.

Water in the PVT system could cause the drive belt to become wet and slip in the clutches. Always avoid spraying water directly toward any intake pre-filters ①. If water does enter the PVT intake, follow the procedure on page.

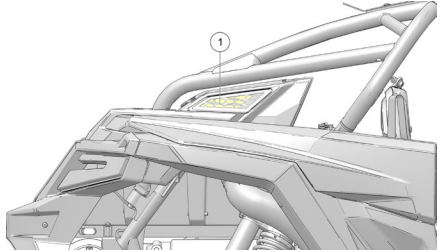

Certain products, including insect repellents and chemicals, will damage plastic surfaces. Do not allow these types of products to contact the TRACTOR.

The best way to clean your EGIMOTORS TRACTOR is with a garden hose and a pail of mild soap and water.

1. Use a professional-type washing cloth, cleaning the upper body first and the lower parts last.
2. Rinse with clean water frequently.
3. Dry surfaces with a chamois to prevent water spots.

WASHING TIPS

- Avoid the use of harsh cleaners, which can damage the finish.
- Do not use medium to heavy duty compounds on the finish.
- Always use clean cloths and pads for cleaning and polishing. Old or reused cloths and pads may contain dirt particles that will scratch the finish.
- Do not use high-speed polishers/buffers on body panels, as damage or color fading may occur.

USING A HIGH PRESSURE WATER SYSTEM

If warning and safety labels are damaged, contact your EGIMOTORS dealer for free replacement.

Grease all zerk fittings immediately after washing. Allow the engine to run for a while to evaporate any water that may have entered the engine or exhaust system.

MAINTENANCE

If a high pressure water system is used for cleaning (not recommended), exercise extreme caution. The water may damage components and could remove paint and labels. High water pressure may damage radiator fins and impair a radiator's effectiveness. High pressure may also damage other TRACTOR components. Avoid directing the water stream at the following items:

- Wheel bearings
- Radiator
- Transmission seals
- Brakes
- Cab and body panels
- Labels and decals
- Electrical components and wiring
- Air intake components
- Throttle and shift cables and controls
- Seat Belts
- Seats

WARNING

Spilled oil left on engine components or in the engine area may pose a fire hazard. Use shop rags to clean any spilled oil. If needed, use a non-flammable solvent on the rag to aid in the cleaning process. Do not use any device such as a pressurized water or air as this may disperse the oil onto engine components and could pose a fire hazard.

WARNING

Clean seat belts with warm water. Avoid damaging seat belts:

- Do not use bleach, dye or household detergents.
- Never use lubricant on any seat belt component.
- Do not use a pressure washer to clean the seat belts.

POLISHING THE TRACTOR

EGIMOTORS recommends the use of common household aerosol furniture polish for polishing the finish on your EGIMOTORS TRACTOR. Follow the instructions on the container.

POLISHING TIPS

- Avoid the use of automotive products, some of which can scratch the finish of your TRACTOR.
- Always use clean cloths and pads for cleaning and polishing. Old or reused cloths and pads may contain dirt particles that will scratch the finish.
- Avoid the use of products containing a colorant dye. Test any products on an inconspicuous area of the TRACTOR before using throughout.

STORAGE TIPS

NOTICE

Starting the engine during the storage period will disturb the protective film created by fogging and damage could occur. Never start the engine during the storage period.

CLEAN THE EXTERIOR

Make any necessary repairs and clean the TRACTOR as recommended. See the Washing the TRACTOR section for details.

STABILIZE THE FUEL

1. Fill the fuel tank.
2. Add EGIMOTORS Carbon Clean Fuel Treatment or EGIMOTORS Fuel Stabilizer or equivalent fuel treatments or stabilizers. Follow the instructions on the container for the recommended amount. Carbon Clean removes water from fuel systems, stabilizes fuel and removes carbon deposits from pistons, rings, valves and exhaust systems.
3. Allow the engine to run for 15-20 minutes to allow the stabilizer to disperse through the entire fuel delivery system.

OIL AND FILTER

Change the oil and filter. See the Oil and Filter Change section for details.

AIR FILTER / AIR BOX

Replace the air filter. See the Air Filter section for details. Clean the air box.

FLUID LEVELS

Inspect the fluid levels. Add or change fluids as recommended in the Periodic Maintenance Chart section.

MAINTENANCE

- Demand drive fluid (front gearcase)
- Rear gearcase fluid (if equipped)
- Transmission fluid
- Brake fluid (change every two years and any time the fluid looks dark or contaminated)
- Coolant (test strength/fill)

INSPECT AND LUBRICATE

Inspect all cables and lubricate all areas of the TRACTOR as recommended in the Periodic Maintenance Chart section.

FOG THE ENGINE

1. Treat the fuel system with EGIMOTORS Carbon Clean or other equivalent fuel treatment. Follow the instructions on the container. Start the engine. Allow it to idle for several minutes so the Carbon Clean reaches the injectors. Stop the engine.
2. Remove the spark plugs and add 2-3 tablespoons of engine oil. To access the plug holes, use a section of clear 1/4" hose and a small plastic squeeze bottle filled with the pre-measured amount of oil. *Do this carefully! If you miss the plug holes, oil will drain from the spark plug cavities into the hole at the front of the cylinder head, and appear to be an oil leak.*
3. Reinstall the spark plugs. Torque to specification. See the Spark Plug Gap / Torque section for details.
4. Apply dielectric grease to the inside of each spark plug cap. *Do not reinstall the caps onto the plugs at this step.*
5. Turn the engine over several times. Oil will be forced in and around the piston rings and ring lands, coating the cylinder with a protective film of fresh oil.
6. If EGIMOTORS fuel system additive is not used, fuel tank, fuel lines, and injectors should be completely drained of gasoline.
7. Reinstall the spark plug caps to the spark plugs.

BATTERY MAINTENANCE

See Battery section for storage and charging procedures.

FUSE BOX

Remove the fuse box cover during storage.

STORAGE AREA / COVERS

Be sure the storage area is well ventilated. Cover the TRACTOR with a genuine EGIMOTORS cover. Do not use plastic or coated materials. They do not allow enough ventilation to prevent condensation, and may promote corrosion and oxidation.

REMOVAL FROM STORAGE

1. Charge the battery if necessary.
2. Make sure the spark plug is tight. Reinstall the fuse box cover if it was removed for storage.
3. Fill the fuel tank with fuel.
4. Check all the points listed in the Daily Pre-Ride Inspection section. Tightness of the bolts, nuts and other fasteners should be checked by an authorized EGIMOTORS dealer or other qualified service facility.
5. Lubricate at the intervals outlined in the Periodic Maintenance Chart section.

 **WARNING**

Engine exhaust contains poisonous carbon monoxide and can cause loss of consciousness or death. Never run an engine in an enclosed area.

MAINTENANCE

TRAILERING SAFETY

The weight distribution of the cargo loaded onto the trailer is important and will have an impact on how the TRACTOR handles on the road. Ensure the weight of the cargo is distributed properly and the trailer is not rear, front, or side heavy.

Improperly trailering or attempting to tow this TRACTOR can result in serious injury or death. Improper transportation can also cause TRACTOR damage, which may involve parts flying off and creating road hazards for other motorists.

Face the TRACTOR forward.

When using a non-enclosed trailer, face the TRACTOR forward or remove the roof and windshield.

Always use a spotter if you are uncomfortable loading the TRACTOR on your own. A wheel chock or marker can also be used as an indication of how close you will park the TRACTOR from the front of the trailer.

Ensure everything in the TRACTOR is secure.

Walk around the TRACTOR and make sure:

- Doors are latched
- Front hood and storage compartments are locked
- Rear seat backs are latched
- Cargo is secured or removed
- TRACTOR is in PARK (P)

Use designated tie down points.

This TRACTOR is equipped with four tie down points for transport. Route straps so that they cannot contact any part of the TRACTOR and become worn or loose during transport. Do not use winch to secure TRACTOR to trailer.

Towing this TRACTOR is not recommended.

Transport this TRACTOR on a trailer or flatbed with all four wheels off the ground. If it is unavoidable to tow this TRACTOR when it is disabled, place this TRACTOR's transmission in NEUTRAL and tow the shortest distance possible. Do not tow this TRACTOR faster than 16 km/h.

Use suitable tie downs.

Securing devices, such as tie down straps, are manufactured to support a maximum strength or load limit that can be applied during normal service. This is known as the Working Load Limit (WLL). Each tie-down strap must have a WLL exceeding the minimum WLL.

TRACTOR TYPE	TIE-DOWN MINIMUM WLL
All TRACTORS	1497 kg

TRANSPORTING THE TRACTOR

WARNING

Cargo and other loose TRACTOR parts may fly off while transporting this TRACTOR.

Secure or remove all cargo, and inspect the unit for loose parts prior to transport.

If transporting the TRACTOR in a non-enclosed trailer, then the TRACTOR must FACE FORWARD, or roof and windshield must be removed.

Failure to comply may allow airflow, vibration, or other factors to separate the roof from the TRACTOR and cause an accident, resulting in serious personal injury or death.

NOTE

For functional descriptions detailing how to operate the DYNAMIX suspension system on certain TRACTOR models, consult the DYNAMIX Suspension

Follow these procedures when transporting the TRACTOR.

NOTICE

After a ride, allow the engine to idle for 30 seconds before stopping the engine. This will allow the system to cool down.

1. Place the transmission in PARK.
2. Stop the engine. Turn the key back on to the accessory or ON position without starting the engine. Slowly release the brake pedal and make sure the transmission is in PARK before exiting the TRACTOR, verifying that the PARK position is shown on the display.
3. Prior to securing the TRACTOR, the key switch must remain in the ON position, the suspension mode switch must be in the COMFORT setting, and the demo mode timeout must not be active while securing the TRACTOR. Shock damping settings can be verified on the Suspension visualization screen.
4. Secure the TRACTOR.

WARNING

TRACTORs equipped with DYNAMIX active suspension must be powered on, set to COMFORT mode, and properly functioning in order to ensure the shocks are operating at their minimum compression damping setting prior to securing the TRACTOR for transport. Failure to ensure the shocks are in their minimum compression damping setting prior to securing the TRACTOR can potentially lead to a reduction of intended strap tension while trailering.

MAINTENANCE

5. After the TRACTOR has been secured, verify the gauge indicates PARK, and turn the TRACTOR power off. Verify also that the suspension compression damping values are still soft after securing the TRACTOR. If after securing the suspension demo mode has timed out or the suspension has moved to a FIRM setting as indicated on the Suspension control screen, cycle the key switch, place the mode switch in COMFORT mode, and re-tighten the straps per step number 3.
6. Remove the key to prevent loss during transporting. Secure the fuel cap and seats. Ensure that the seats are attached correctly and are not loose.

WARNING

Cargo and other loose TRACTOR parts may fly off while transporting this TRACTOR.

Secure or remove all cargo, and inspect the unit for loose parts prior to transport.

7. Always tie the frame of the EGIMOTORS TRACTOR to the transporting unit securely with suitable straps or rope. Do not attach tie straps to the front control arm bolt pockets.

① Rear Tie-Down (both sides)

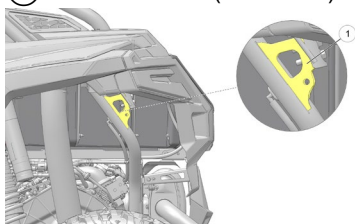

② Front Tow Loop Tie-Down

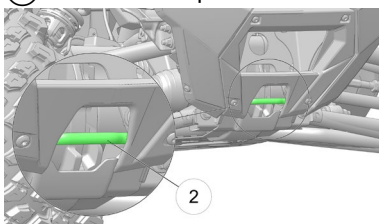

SPECIFICATIONS

RZR PRO XP

Gross TRACTOR Weight*	
ULTIMATE: 1321 kg	
Dry Weight	
ULTIMATE: 985 kg	
*Dry weight is also listed on the Certificate of Origin for your TRACTOR in the Shipping Weight field. The dry weight is estimated based on the manufactured weight of the TRACTOR minus any serviceable fluids and may also exclude the weight of factory installed accessories not essential to the TRACTOR's basic operation as outlined in the ANSI®/ROHVA SM 1-2023 standard.	
Rear Cargo Box Capacity	136 kg
Maximum Weight Capacity (Payload)	336 kg (including riders, cargo and accessories)
Fuel Capacity	46.5 L
Engine Oil Capacity	2.6 L
Coolant Capacity	11.3 L
Demand Drive Fluid Capacity	280 ml
Transmission Oil Capacity	1800 ml
Overall Length/Width/Height	320.4 / 162.6 / 182.1 cm
Wheelbase	243.8 c
Ground Clearance	36.8 cm
Engine	4-Stroke DOHC Twin Cylinder

SPECIFICATIONS

Displacement	925 cc
Bore x Stroke	93mm x 68mm
Alternator Output	900W @ 3000 RPM
Compression Ratio	9.0:1
Starting System	Electric
Fuel System	Electronic fuel injection
Ignition System	ECU
Spark Plug / Gap	NGK® MR9F / 0.7-0.8 mm
Front Suspension	Independent double a-arm with 43.2 cm travel
Rear Suspension	Independent trailing arms with 50.8 cm travel
Lubrication System	Wet Sump
Driving System Type	Automatic EGIMOTORS Variable Transmission
Shift Type	Automatic PVT P/R/N/L/H
Tire Size - Front	30x10 R14
Tire Size - Rear	30x10 R14
Tire Pressure	Front: 69 kPa Rear: 138 kPa
Brakes, Front/Rear	Foot Activated, 4-wheel hydraulic disc
Headlights	2 dual beam LED cluster
Taillights	2 LED cluster
Brake Lights	2 LED cluster
Instrument Cluster	LCD
Auxiliary DC Outlet	12V

RZR PRO XP 4

Gross TRACTOR Weight*	
ULTIMATE: 1493 kg	
Dry Weight*	
ULTIMATE: 1085 kg	
*Dry weight is also listed on the Certificate of Origin for your TRACTOR in the Shipping Weight field. The dry weight is estimated based on the manufactured weight of the TRACTOR minus any serviceable fluids and may also exclude the weight of factory installed accessories not essential to the TRACTOR's basic operation as outlined in the ANSI®/ROHVA SM 1-2023 standard.	
Rear Cargo Box Capacity	136 kg
Maximum Weight Capacity (Payload)	408 kg (including riders, cargo and accessories)
Fuel Capacity	49.9 L
Engine Oil Capacity	2.6 L
Coolant Capacity	11.3 L
Demand Drive Fluid Capacity	280 ml
Transmission Oil Capacity	1800 ml
Overall Length/Width/Height	394.0 / 162.6 / 186.9 cm
Wheelbase	318 cm
Ground Clearance	36.8 cm
Engine	4-Stroke DOHC Twin Cylinder
Displacement	925 cc

SPECIFICATIONS

Bore x Stroke	93mm x 68mm
Alternator Output	900W @ 3000 RPM
Compression Ratio	9.0:1
Starting System	Electric
Fuel System	Electronic fuel injection
Ignition System	ECU
Spark Plug / Gap	NGK® MR9F / 0.7-0.8 mm
Front Suspension	Independent double a-arm with 43.2 cm travel
Rear Suspension	Independent trailing arms with 50.8 cm travel
Lubrication System	Wet Sump
Driving System Type	Automatic EGIMOTORS Variable Transmission
Shift Type	Automatic PVT P/R/N/L/H
Tire Size - Front	30x10 R14
Tire Size - Rear	30x10 R14
Tire Pressure	Front: 97 kPa Rear: 165 kPa
Brakes, Front/Rear	Foot Activated, 4-wheel hydraulic disc
Headlights	2 dual beam LED cluster
Taillights	2 LED cluster
Brake Lights	2 LED cluster
Instrument Cluster	LCD
Auxiliary DC Outlet	12V

OUTPUT GEAR RATIOS

Rear	
High Gear	12.65:1
Low Gear	35.37:1
Reverse	33.60:1
Front (including front drive)	
High Gear	13.3:1
Low Gear	37.21:1
Reverse	35.34:1
Drive Ratio - Front	3.17:1

CLUTCHING

See your EGIMOTORS dealer or qualified person for clutching specifications.

For operation at high elevation, different clutching parts may be needed. See your EGIMOTORS dealer for more information.

EGIMOTORS PRODUCTS

LUBRICANTS / SERVICE PRODUCTS

PART NUMBER	DESCRIPTION
Engine Lubricant	
2870791	Fogging Oil — 355 mL Aerosol
2876244	PS-4 Full Synthetic 5W-50 4-Cycle Oil — 0.95 L
2876245	PS-4 Full Synthetic 5W-50 4-Cycle Oil — 3.8 L
2889395	PS-4 Extreme Full Synthetic 0W-50 4-Cycle Oil — 0.95 L
2889396	PS-4 Extreme Full Synthetic 0W-50 Engine Oil — 3.8 L
Gearcase / Transmission Lubricants	
2878068	AGL Full Synthetic Gearcase Lubricant & Transmission Fluid — 0.95 L
2878069	AGL Full Synthetic Gearcase Lubricant & Transmission Fluid — 3.8 L
2877922	Demand Drive Fluid — 0.95 L
2877923	Demand Drive Fluid — 3.8 L
2870465	Pump for 3.8 L
Coolant	
2880514	Antifreeze 50/50 Premix — 0.95 L
2880513	Antifreeze 50/50 Premix — 3.8 L
Grease / Specialized Lubricants	
2871312	Grease Gun Kit, All Season Grease
2871322	All Season Grease — 89 mL Cartridge
2871423	All Season Grease — 414 mL Cartridge
2876160	TRACTOR Angle Drive Fluid — 0.95 L

EGIMOTORS PRODUCTS

PART NUMBER	DESCRIPTION
2872276	TRACTOR Angle Drive Fluid — 9.5 L
2871460	Premium Starter Grease
2871515	U-Joint Grease — 89 mL Cartridge
2871551	U-Joint Grease — 414 mL Cartridge
2871329	Dielectric Grease (Nyogel®)
Additives / Miscellaneous	
2871326	Carbon Clean
2870652	Fuel Stabilizer
2872189	DOT 4 Brake Fluid
2871956	Loctite® 565 Thread Sealant
2830438	EGIMOTORS Battery Trickle Charger

TROUBLESHOOTING

DRIVE BELT WEAR / BURN

POSSIBLE CAUSE	SOLUTION
Driving onto a pickup or tall trailer in high range	Use low range during loading.
Starting out going up a steep incline	Use low range.
Driving at low RPM or ground speed 5–12 km/h	Drive at a higher speed or use low range more frequently.
Insufficient warm-up at low ambient temperatures	Warm the engine at least 5 minutes. With the transmission in neutral, advance the throttle to about 1/8 throttle in short bursts, five to seven times. The belt will become more flexible and prevent belt burning. Always warm up the belt by operating below 48 km/h for 1.6 km. When the temperature is below freezing, extend the belt warming time to 8 km.
Slow/easy clutch engagement	Use the throttle quickly and effectively.
Towing/pushing at low RPM/low ground speed	Use low range only.
Utility use/plowing	Use low range only.
Stuck in mud or snow	Shift the transmission to low range and carefully use fast, aggressive throttle application to engage clutch. WARNING: Excessive throttle may cause loss of control and TRACTOR rollover.
Climbing over large objects from a stopped position	Shift the transmission to low range and carefully use fast, brief, aggressive throttle application to engage clutch. WARNING: Excessive throttle may cause loss of control and TRACTOR rollover.
Belt slippage from water or snow ingestion into the PVT system	Dry out the PVT. See PVT Drying procedure. Prevent water from entering the PVT intake duct. See Intake Pre-Filters for more information. Inspect clutch seals for damage if repeated leaking occurs.
Clutch malfunction	See your EGIMOTORS dealer or other qualified person.
Poor engine performance	Check for clogged air filter, clogged fuel filter, water in the fuel or foreign material in fuel tank or fuel lines. An authorized dealer can assist.
Wrong belt	Install the recommended belt.
Improper break-in	Always break in a new belt and/or clutch. See PVT Break-in procedure.

TROUBLESHOOTING

TRACTOR PULLS TO ONE SIDE WHILE DRIVING

POSSIBLE CAUSE	SOLUTION
Steering components out of adjustment	Your EGIMOTORS dealer or other qualified person can assist.
Bent / broken steering components	Your EGIMOTORS dealer or other qualified person can assist.
Power steering center position incorrect	Remove and replace the power steering fuse, then cycle the ignition on / off. When the fuse is removed, the EPS will automatically re-learn the center position while driving in a straight line. Steering may be slightly different until a new center position has been learned. If the TRACTOR continues to pull to one side, see your EGIMOTORS dealer or other qualified person.

ENGINE PINGS OR KNOCKS

POSSIBLE CAUSE	SOLUTION
Poor quality or low octane fuel	Replace with recommended fuel
Incorrect ignition timing	Your EGIMOTORS dealer or other qualified person can assist.
Incorrect spark plug gap or heat range	Set gap to specs or replace plugs

ENGINE DOESN'T TURN OVER

POSSIBLE CAUSE	SOLUTION
Low battery voltage	Recharge the battery to 12.8 VDC
Loose battery connections	Check all connections and tighten
Loose solenoid connections	Check all connections and tighten
Loose electronic control box connections	Inspect, clean, reinstall connectors; blow on EFI fuse to remove impurities
Mechanical failure	Your EGIMOTORS dealer or other qualified person can assist.

ENGINE TURNS OVER, FAILS TO START

POSSIBLE CAUSE	SOLUTION
Out of fuel	Refuel
Clogged fuel filter	Your EGIMOTORS dealer or other qualified person can assist.
Water is present in fuel	Drain the fuel system and refuel
Old or non-recommended fuel	Replace with fresh recommended fuel
Fouled or damaged spark plugs	Inspect plugs and replace if necessary
No spark to spark plug	Inspect plugs and replace if necessary
Water or fuel in crankcase	Your EGIMOTORS dealer or other qualified person can assist.
Low battery voltage	Recharge the battery to 12.8 VDC
Loose ignition connections	Check all connections and tighten
Mechanical failure	Your EGIMOTORS dealer or other qualified person can assist.

TROUBLESHOOTING

ENGINE BACKFIRES

POSSIBLE CAUSE	SOLUTION
Out of fuel	Refuel
Weak spark from spark plug	Inspect, clean and/or replace spark plugs
Incorrect spark plug gap or heat range	Set gap to specs or replace plugs
Old or non-recommended fuel	Replace with fresh recommended fuel
Incorrectly installed spark plug wires	Your EGIMOTORS dealer or other qualified person can assist.
Incorrect ignition timing	Your EGIMOTORS dealer or other qualified person can assist.
Loose ignition connections	Check all connections and tighten
Water present in fuel	Replace with fresh recommended fuel
Exhaust leak	Check all connections
Mechanical failure	Your EGIMOTORS dealer or other qualified person can assist.

ENGINE RUNS IRREGULARLY, STALLS, OR MISFIRES

POSSIBLE CAUSE	SOLUTION
Fouled or defective spark plugs	Inspect, clean and/or replace spark plugs
Worn or defective spark plug wires	Your EGIMOTORS dealer or qualified person can assist
Incorrect spark plug gap or heat range	Set gap to specs or replace plugs
Loose ignition connections	Check all connections and tighten
Water present in fuel	Replace with new fuel
Low battery voltage	Recharge battery to 12.8 VDC
Kinked or plugged fuel tank vent line or filter	Inspect and replace
Kinked idle air control lines	Inspect; rotate lines to remove kink
Incorrect fuel	Replace with recommended fuel
Clogged air filter	Inspect and replace clogged/wet air filter, and also check for obstructed intake system, debris or cargo blocking intake vents
Clogged intake pre-filter	Inspect and clean (with soapy water) or replace
Other mechanical failure	See your dealer

POSSIBLE LEAN FUEL CAUSE	SOLUTION
Low or contaminated fuel	Add or change fuel, clean the fuel system
Low octane fuel	Replace with recommended fuel
Clogged fuel filter	See your dealer
Low fuel pressure	See your dealer

TROUBLESHOOTING

ENGINE STOPS OR LOSES POWER

POSSIBLE CAUSE	SOLUTION
Out of fuel	Refuel
Kinked or plugged fuel tank vent line or filter	Inspect and replace
Water is present in fuel	Replace with new fuel
Fouled or defective spark plugs	Inspect, clean and/or replace spark plug
Worn or defective spark plug wires	See your dealer
Incorrect spark plug gap or heat range	Set gap to specs or replace plug
Loose ignition connections	Check all connections and tighten
Low battery voltage	Recharge the battery to 12.8 VDC
Incorrect fuel	Replace with fresh recommended fuel
Clogged air filter	Inspect and replace clogged/wet air filter, and also check for obstructed intake system, debris or cargo blocking intake vents
Clogged intake pre-filter	Inspect and clean (with soapy water) or replace
Other mechanical failure	See your dealer
Overheated engine	Clean radiator screen and core, clean engine exterior, check coolant level, see your dealer if condition persists

DIAGNOSTIC DISPLAY CODE DEFINITIONS

Open Load: There is a break in the wires that lead to the item listed in the chart (injector, fuel pump, etc.), or the item has failed.

Short-to-Ground: The wire is shorted to ground between the electronic control unit and the item listed in the chart.

Shorted Load: The wires leading to the item listed in the chart are shorted together, or the item has shorted internally.

Short-to-Battery: The wire leading from the item listed in the chart to the electronic control unit is shorted to a wire at battery voltage.

ENGINE CONTROL MODULE			
COMPONENT	CONDITION	SPN	FMI
Accelerator Position 2	Voltage Above Normal, Or Shorted To High Source	29	3
	Voltage Below Normal, Or Shorted To Low Source		4
Throttle Position Sensor 1	Voltage Above Normal, Or Shorted To High Source	51	3
	Voltage Below Normal, Or Shorted To Low Source		4
TRACTOR Speed Sensor	Data Erratic, Intermittent Or Incorrect	84	2
Accelerator Position 1	Voltage Above Normal, Or Shorted To High Source	91	3
	Voltage Below Normal, Or Shorted To Low Source		4
	Voltage Above Normal, Or Shorted To High Source		3
	Voltage Below Normal, Or Shorted To Low Source		4
Manifold Absolute Pressure Sensor	Voltage Above Normal, Or Shorted To High Source	102	3
	Voltage Below Normal, Or Shorted To Low Source		4
Intake Air Temperature Sensor	Data Valid But Above Normal Operational Range - Most Severe Level	105	0
	Voltage Above Normal, Or Shorted To High Source		3
	Voltage Below Normal, Or Shorted To Low Source		4

TROUBLESHOOTING

ENGINE CONTROL MODULE			
COMPONENT	CONDITION	SPN	FMI
Barometric Pressure Sensor	Voltage Above Normal, Or Shorted To High Source	108	3
	Voltage Below Normal, Or Shorted To Low Source		4
Engine Temperature Sensor	Data Valid But Above Normal Operational Range - Most Severe Level	110	0
	Data Erratic, Intermittent Or Incorrect		2
	Voltage Above Normal, Or Shorted To High Source		3
	Voltage Below Normal, Or Shorted To Low Source		4
	Abnormal Rate Of Change		10
	Data Valid But Above Normal Operating Range - Moderately Severe Level		16
Fuel Rail Pressure Sensor	Data Erratic, Intermittent Or Incorrect	157	2
	Voltage Above Normal, Or Shorted To High Source		3
	Voltage Below Normal, Or Shorted To Low Source		4
	Data Valid But Above Normal Operating Range - Least Severe Level		15
	Data Valid But Below Normal Operating Range - Least Severe Level		17
	Data Valid But Below Normal Operational Range - Most Severe Level		1

TROUBLESHOOTING

ENGINE CONTROL MODULE			
COMPONENT	CONDITION	SPN	FMI
	Data Erratic, Intermittent Or Incorrect		2
	Voltage Above Normal, Or Shorted To High Source		3
	Voltage Below Normal, Or Shorted To Low Source		4
	Data Valid But Below Normal Operating Range - Moderately Severe Level		18
Engine Speed	Condition Exists	190	31
Gear Sensor Signal	Data Erratic, Intermittent Or Incorrect	523	2
Crankshaft Position Sensor	Data Erratic, Intermittent Or Incorrect	636	2
Injector 1 (Front) (MAG) (SDI Port Injector)	Voltage Above Normal, Or Shorted To High Source	651	3
	Voltage Below Normal, Or Shorted To Low Source		4
	Current Below Normal Or Open Circuit		5
Injector 2 (Rear) (PTO) (SDI Port Injector)	Voltage Above Normal, Or Shorted To High Source	652	3
	Voltage Below Normal, Or Shorted To Low Source		4
	Current Below Normal Or Open Circuit		5
Starter Solenoid Driver Circuit	Voltage Above Normal, Or Shorted To High Source	677	3
	Voltage Below Normal, Or Shorted To Low Source		4
	Current Below Normal Or Open Circuit		5

TROUBLESHOOTING

ENGINE CONTROL MODULE			
COMPONENT	CONDITION	SPN	FMI
Knock Sensor 1	Data Valid But Below Normal Operational Range - Most Severe Level	731	1
Fan Relay Driver Circuit	Voltage Above Normal, Or Shorted To High Source	1071	3
	Voltage Below Normal, Or Shorted To Low Source		4
	Current Below Normal Or Open Circuit		5
Boost Pressure Sensor	Data Valid But Above Normal Operational Range - Most Severe Level	1127	0
	Data Erratic, Intermittent Or Incorrect		2
	Voltage Above Normal, Or Shorted To High Source		3
	Voltage Below Normal, Or Shorted To Low Source		4
	Condition Exists		31
Ignition Coil Primary Driver 1 (Front) (MAG)	Voltage Above Normal, Or Shorted To High Source	1268	3
Ignition Coil Primary Driver 2 (Rear) (PTO)	Voltage Above Normal, Or Shorted To High Source	1269	3
PWM Fuel Pump	Voltage Above Normal, Or Shorted To High Source	1347	3
	Voltage Below Normal, Or Shorted To Low Source		4
	Current Below Normal Or Open Circuit		5
Fuel Pump Module Errors	Abnormal Frequency Or Pulse Width Or Period		8

TROUBLESHOOTING

ENGINE CONTROL MODULE			
COMPONENT	CONDITION	SPN	FMI
	Voltage Below Normal, Or Shorted To Low Source		4
Oxygen Sensor Bank 1 Sensor 1	Data Erratic, Intermittent Or Incorrect	3056	2
	Voltage Above Normal, Or Shorted To High Source		3
	Voltage Below Normal, Or Shorted To Low Source		4
	Bad Intelligent Device Or Component		12
ECU Output Supply Voltage 1	Voltage Above Normal, Or Shorted To High Source	3597	3
	Voltage Below Normal, Or Shorted To Low Source		4
ECU Output Supply Voltage 2	Voltage Above Normal, Or Shorted To High Source	3598	3
	Voltage Below Normal, Or Shorted To Low Source		4
ECU Output Supply Voltage 3	Voltage Above Normal, Or Shorted To High Source	3599	3
	Voltage Below Normal, Or Shorted To Low Source		4
Cylinder Misfire	Mechanical System Not Responding Or Out Of Adjustment	65590	7
Cylinder 1 Misfire	Mechanical System Not Responding Or Out Of Adjustment	65591	7
Cylinder 2 Misfire	Mechanical System Not Responding Or Out Of Adjustment	65592	7

TROUBLESHOOTING

ENGINE CONTROL MODULE			
COMPONENT	CONDITION	SPN	FMI
ETC Accelerator Position Sensor Outputs 1 & 2 Correlation	Data Erratic, Intermittent Or Incorrect	65613	2
Fuel Pump Controller	Abnormal Frequency Or Pulse Width Or Period	66028	8
	Bad Intelligent Device Or Component		12
Throttle Position Sensor 2	Voltage Above Normal, Or Shorted To High Source	520198	3
	Voltage Below Normal, Or Shorted To Low Source		4
Canister Purge Valve	Voltage Above Normal, Or Shorted To High Source	520202	3
	Voltage Below Normal, Or Shorted To Low Source		4
	Current Below Normal Or Open Circuit		5
All Wheel Drive Control Circuit	Voltage Above Normal, Or Shorted To High Source	520207	3
	Voltage Below Normal, Or Shorted To Low Source		4
	Current Below Normal Or Open Circuit		5
Chassis Relay	Voltage Above Normal, Or Shorted To High Source	520208	3
	Voltage Below Normal, Or Shorted To Low Source		4
	Current Below Normal Or Open Circuit		5
Oxygen Sensor Heater 1	Data Erratic, Intermittent Or Incorrect	520209	2

TROUBLESHOOTING

ENGINE CONTROL MODULE			
COMPONENT	CONDITION	SPN	FMI
	Voltage Above Normal, Or Shorted To High Source		3
	Voltage Below Normal, Or Shorted To Low Source		4
	Current Below Normal Or Open Circuit		5
Accelerator Position/Brake Position Interaction	Condition Exists	520275	31
Throttle Position Sensor (1 or 2 Indeterminable)	Data Erratic, Intermittent Or Incorrect	520276	2
	Bad Intelligent Device Or Component		12
Throttle Body Control - Power Stage	Data Erratic, Intermittent Or Incorrect	520277	2
	Voltage Above Normal, Or Shorted To High Source		3
	Voltage Below Normal, Or Shorted To Low Source		4
	Abnormal Frequency Or Pulse Width Or Period		8
Throttle Body Control - Adaption Aborted	Condition Exists	520279	31
Throttle Body Control - Limp Home Position Check Failed	Condition Exists	520280	31
Throttle Body Control - Mechanical Stop Adaptation Failure	Condition Exists	520281	31

TROUBLESHOOTING

ENGINE CONTROL MODULE			
COMPONENT	CONDITION	SPN	FMI
Throttle Body Control - Repeated Adaptation Failed	Condition Exists	520282	31
Throttle Body Control	Voltage Above Normal, Or Shorted To High Source	520283	3
	Voltage Below Normal, Or Shorted To Low Source		4
Throttle Body Control - Position Deviation Fault	Condition Exists	520284	31
Brake Switch (1 or 2 Indeterminable)	Data Erratic, Intermittent Or Incorrect	520285	2
ECU Monitoring Error	Condition Exists	520286	31
ECU Monitoring Error (Level 3)	Condition Exists	520287	31
ECU Monitoring of Injection Cut Off (Level 1)	Condition Exists	520288	31
ECU Monitoring of Injection Cut Off (Level 2)	Condition Exists	520289	31
Throttle Body Control - Requested Throttle Angle Not Plausible	Condition Exists	520305	31
ECU ADC Fault - No Load	Condition Exists	520306	31
ECU ADC Fault - Voltage	Condition Exists	520307	31
Accelerator Sensor Sync Fault - Sensor Diff Exceeds Limit	Condition Exists	520308	31

TROUBLESHOOTING

ENGINE CONTROL MODULE			
COMPONENT	CONDITION	SPN	FMI
ECU Fault - ICO	Condition Exists	520309	31
ECU Fault - Hardware Disruption	Condition Exists	520311	31
Knock Sensor Positive Line	Voltage Above Normal, Or Shorted To High Source	520331	3
	Voltage Below Normal, Or Shorted To Low Source		4
Knock Sensor Negative Line	Voltage Above Normal, Or Shorted To High Source	520332	3
	Voltage Below Normal, Or Shorted To Low Source		4
ECU Monitoring (Pedal Map Mismatch)	Condition Exists	520336	31
Wastegate Solenoid Driver	Voltage Above Normal, Or Shorted To High Source	520341	3
	Voltage Below Normal, Or Shorted To Low Source		4
	Current Below Normal Or Open Circuit		5
Adaptive Fuel Correction Bank 1	Data Valid But Above Normal Operating Range - Least Severe Level	520344	15
	Data Valid But Below Normal Operating Range - Least Severe Level		17
Intercooler Pump Driver Circuit	Voltage Above Normal, Or Shorted To High Source	520496	3
	Voltage Below Normal, Or Shorted To Low Source		4
	Current Below Normal Or Open Circuit		5

TROUBLESHOOTING

ENGINE CONTROL MODULE			
COMPONENT	CONDITION	SPN	FMI
Wideband Oxygen Sensor Bank 1 Sensor 1 Pumping Current Trim	Current Below Normal Or Open Circuit	520612	5
Wideband Oxygen Sensor Bank 1 Sensor 1 Positive Current Control	Current Below Normal Or Open Circuit	520613	5
Wideband Oxygen Sensor Bank 1 Sensor 1 Negative Current Control	Current Below Normal Or Open Circuit	520614	5
Wideband Oxygen Sensor Bank 1 Sensor 1 Reference Voltage	Current Below Normal Or Open Circuit	520615	5
Wideband Chip	Bad Intelligent Device Or Component	520679	12
Start Switch	Data Erratic, Intermittent Or Incorrect	521083	2

EPAS MODULE			
COMPONENT	CONDITION	SPN	FMI
Steering Over Current Shut Down	Current Above Normal Or Grounded Circuit	520221	6
Steering Excessive Current Error	Current Above Normal Or Grounded Circuit	520222	6
Steering Torque Partial Failure	Condition Exists	520223	31
Steering Torque Full Failure	Condition Exists	520224	31
EPAS Inverter Temperature	Data Valid But Above Normal Operational Range - Most Severe	520225	0

TROUBLESHOOTING

EPAS MODULE			
COMPONENT	CONDITION	SPN	FMI
	Data Valid But Above Normal Operating Range - Severe		16
EPAS Communications Receive Data Error	Data Erratic, Intermittent Or Incorrect	520226	2
	Condition Exists	520226	31
Position Encoder Error	Root Cause Not Known	520228	11
	Bad Intelligent Device Or Component	520228	12
	Condition Exists	520228	31
EPAS Software Error	Bad Intelligent Device Or Component	520229	12
	Condition Exists	520229	31
EPAS Power Save Condition	Condition Exists	520231	31
EPS SEPIC Voltage Error	Voltage Above Normal, Or Shorted To High Source	524086	3
	Voltage Below Normal, Or Shorted To Low Source	524086	4
Calibration CRC	Checksum/CRC Error	630	13
Steering Torque Full Failure	Torque Sensor Out of Range	520223	31
	Torque Sensor Linearity Error	520224	31
EPS CAN Communications Receive Error	No RX Message for {{cal parameter}} seconds	520226	2
TRACTOR Speed	TRACTOR Speed Too High	84	0
	TRACTOR Speed Implausible		10
	Received TRACTOR Speed has Errors		19
Engine Speed	Engine Speed Too High	190	0

TROUBLESHOOTING

EPAS MODULE			
COMPONENT	CONDITION	SPN	FMI
	Received Engine Speed has Errors	190	19
Battery Voltage	Too High	168	3
Battery Voltage	Too Low	168	4
Position Encoder Error	Loss of SPI Communication	520228	12
	Encoder Variance Error		31
EPS Software Error	Manufacturing CRC Error	520229	12
	Boot Count Error		31
ICS Communication	Loss of CAN between EPS and Instrument Cluster	520230	31
EPAS Power Save	5 minute time out	520231	31
ECU Memory	EEPROM Communication Error	628	12
	Application CRC Error		13
VGD Low	VGD Low	524086	4
Absolute Position Sensor	Absolute Position Sensor Out of Range	1807	31
	Absolute Position Sensor Not Calibrated	1807	13

SUSPENSION CONTROL MODULE			
COMPONENT	CONDITION	SPN	FMI
TRACTOR Speed Sensor	Data Drifted High	84	20
	Data Drifted Low		21
Transmission Requested Range Data	Data Erratic, Intermittent Or Incorrect	162	2
Suspension Mode Switch Input	Data Erratic, Intermittent Or Incorrect	516098	2

TROUBLESHOOTING

SUSPENSION CONTROL MODULE			
COMPONENT	CONDITION	SPN	FMI
	Voltage Above Normal, Or Shorted To High Source		3
	Voltage Below Normal, Or Shorted To Low Source		4
Valve Driver Front Left	Voltage Above Normal, Or Shorted To High Source	516106	3
	Voltage Below Normal, Or Shorted To Low Source		4
Valve Driver Front Right	Voltage Above Normal, Or Shorted To High Source	516107	3
	Voltage Below Normal, Or Shorted To Low Source		4
Valve Driver Rear Left	Voltage Above Normal, Or Shorted To High Source	516108	3
	Voltage Below Normal, Or Shorted To Low Source		4
Valve Driver Rear Right	Voltage Above Normal, Or Shorted To High Source	516109	3
	Voltage Below Normal, Or Shorted To Low Source		4
Shock Valve Power Supply Relay Driver	Voltage Above Normal, Or Shorted To High Source	516110	3
	Voltage Below Normal, Or Shorted To Low Source		4
Absolute Shock Current Error - Front Left	Root Cause Not Known	516111	11
Absolute Shock Current Error - Front Right	Root Cause Not Known	516112	11

TROUBLESHOOTING

SUSPENSION CONTROL MODULE			
COMPONENT	CONDITION	SPN	FMI
Absolute Shock Current Error - Rear Left	Root Cause Not Known	516113	11
Absolute Shock Current Error - Rear Right	Root Cause Not Known	516114	11
Internal Inertial Measurement Unit	Bad Intelligent Device Or Component	516115	12
	Data Valid But Above Normal Operating Range - Least Severe Level		15
	Data Valid But Below Normal Operating Range - Least Severe Level		17
CAN Message PGN 65382	Abnormal Update Rate	516116	9
CAN Message PGN 65396	Abnormal Update Rate	516117	9
CAN Message PGN 65314	Abnormal Update Rate	516118	9
SW Version & HW Version Mismatch	Data Erratic, Intermittent Or Incorrect	516119	2
CAN Message PGN 65265	Abnormal Update Rate	516120	9
CAN Message PGN 61445	Abnormal Update Rate	516121	9
Steering Angle Adoption Offset	Data Valid But Above Normal Operating Range - Least Severe Level	516122	15
TRACTOR Speed Data	Data Erratic, Intermittent Or Incorrect	516123	2
	Data Drifted High		20

SUSPENSION CONTROL MODULE			
COMPONENT	CONDITION	SPN	FMI
Suspension Control Module	Bad Intelligent Device Or Component	516124	12
CAN 1	Root Cause Not Known	516125	11
System Voltage	Data Valid But Above Normal Operational Range - Most Severe Level	516126	0
	Data Valid But Below Normal Operational Range - Most Severe Level		1
	Voltage Above Normal, Or Shorted To High Source		3
	Voltage Below Normal, Or Shorted To Low Source		4
	Data Valid But Above Normal Operating Range - Moderately Severe Level		16
	Data Valid But Below Normal Operating Range - Moderately Severe Level		18
Raw Brake Switch Status	Data Erratic, Intermittent Or Incorrect	520572	2
Normalized Accelerator Pedal Position	Data Erratic, Intermittent Or Incorrect	520574	2
Engine Speed Data	Data Erratic, Intermittent Or Incorrect	524000	2
Steering Angle Input	Data Erratic, Intermittent Or Incorrect	524114	2

WARRANTY

LIMITED WARRANTY

EGIMOTORS gives a TWO YEARS LIMITED WARRANTY on all components of your Tractor against defects in material or workmanship.

This warranty covers parts and labor charges for repair or replacement of defective parts and begins on the date of purchase by the original retail purchaser.

The duration of this warranty may vary by international region based upon local laws and regulations.

REGISTRATION

At the time of sale, the Warranty Registration Form must be completed by your dealer and submitted to EGIMOTORS within ten days of purchase.

Upon receipt of this registration, EGIMOTORS will record the registration for warranty. No verification of registration will be sent to the purchaser as the copy of the Warranty Registration Form will be your proof of warranty coverage. If you have not signed the original registration and received the customer copy, please contact your dealer immediately.

NO WARRANTY COVERAGE WILL BE ALLOWED UNLESS YOUR TRACTOR IS REGISTERED WITH EGIMOTORS.

Initial dealer preparation and set-up of your tractor is very important in ensuring trouble-free operation.

Purchasing a machine in the crate or without proper dealer set-up will void your warranty coverage.

WARRANTY COVERAGE AND EXCLUSIONS

LIMITATIONS OF WARRANTIES AND REMEDIES

This EGIMOTORS limited warranty excludes any failures that are not caused by a defect in material or workmanship. THIS WARRANTY DOES NOT COVER CLAIMS OF DEFECTIVE DESIGN. This warranty also does not cover acts of God, accidental damage, normal wear and tear, abuse or improper handling. This warranty also does not cover damage to any TRACTOR, component, or part as a result of being structurally modified, neglected, improperly maintained or used for racing, competition or purposes other than for which it was designed.

This warranty excludes damages or failures resulting from improper lubrication; improper engine timing; improper fuel; surface imperfections caused by external stress, heat, cold or contamination; operator error or abuse; improper component alignment, tension, adjustment or altitude compensation; snow, water, dirt or other foreign substance ingestion/contamination; improper maintenance; modified components; use of aftermarket or unapproved components, accessories, or attachments; unauthorized repairs; or repairs made after the warranty period expires or by an unauthorized repair center.

This warranty excludes damages or failures caused by abuse, accident, fire, or any other cause other than a defect in materials or workmanship and provides no coverage for consumable components, general wear items, or any parts exposed to friction surfaces, stresses, environmental conditions and/or contamination for which they were not designed or not intended, including but not limited to the following items:

- Wheels and tires
- Suspension components
- Brake components
- Seat components
- Clutches and components
- Steering components
- Batteries
- Light bulbs/Sealed beam lamps
- Filters
- Lubricants
- Brushings
- Finished and unfinished surfaces
- Carburetor/Throttle body components
- Engine components
- Drive belts
- Hydraulic components and fluids
- Circuit breakers/Fuses
- Electronic components
- Spark plugs
- Sealants
- Coolants
- Bearings

LUBRICANTS AND FLUIDS

1. Mixing oil brands or using non-recommended oil may cause engine damage. We recommend the use of EGIMOTORS engine oil.
2. Damage or failure resulting from the use of non-recommended lubricants or fluids is not covered by this warranty.

This warranty provides no coverage for personal loss or expense, including kilometers, transportation costs, hotels, meals, shipping or handling fees, product pick-up or delivery, replacement rentals, loss of product use, loss of profits, or loss of vacation or personal time.

THE EXCLUSIVE REMEDY FOR BREACH OF THIS WARRANTY SHALL BE, AT EGIMOTORS' OPTION, REPAIR OR REPLACEMENT OF ANY DEFECTIVE MATERIALS, COMPONENTS, OR PRODUCTS. THE REMEDIES SET FORTH IN THIS WARRANTY ARE THE ONLY REMEDIES AVAILABLE TO ANY PERSON FOR BREACH OF THIS WARRANTY. EGIMOTORS SHALL HAVE NO LIABILITY TO ANY PERSON FOR INCIDENTAL, CONSEQUENTIAL OR SPECIAL DAMAGES OF ANY DESCRIPTION, WHETHER ARISING OUT OF EXPRESS OR IMPLIED WARRANTY OR ANY OTHER CONTRACT, NEGLIGENCE, OR OTHER TORT OR OTHERWISE. THIS EXCLUSION OF CONSEQUENTIAL, INCIDENTAL, AND SPECIAL DAMAGES IS INDEPENDENT FROM AND SHALL SURVIVE ANY FINDING THAT THE EXCLUSIVE REMEDY FAILED OF ITS ESSENTIAL PURPOSE.

THE IMPLIED WARRANTY OF FITNESS FOR A PARTICULAR PURPOSE IS EXCLUDED FROM THIS LIMITED WARRANTY. ALL OTHER IMPLIED WARRANTIES (INCLUDING BUT NOT LIMITED TO THE IMPLIED WARRANTY OF MERCHANTABILITY) ARE LIMITED IN DURATION TO THE ABOVE TWO YEARS WARRANTY PERIOD. EGIMOTORS DISCLAIMS ALL EXPRESS WARRANTIES NOT STATED IN THIS WARRANTY.

WARRANTY

HOW TO OBTAIN WARRANTY SERVICE

If your tractor requires warranty service, you must take it to a EGIMOTORS Servicing Dealer. When requesting warranty service you must present your copy of the Warranty Registration Form to the dealer. (THE COST OF TRANSPORTATION TO AND FROM THE DEALER IS YOUR RESPONSIBILITY.) EGIMOTORS suggests that you use your original selling dealer; however, you may use any EGIMOTORS Servicing Dealer to perform warranty service.

IN THE COUNTRY WHERE YOUR PRODUCT WAS PURCHASED:

You are responsible for presenting your tractor to an authorized EGIMOTORS dealer as soon as a problem exists. The warranty repairs should be completed in a reasonable amount of time, not to exceed 30 days. However, any damage caused to the product by you or any non-authorized third party may void this warranty. Warranty or Service Bulletin repairs must be done by an authorized EGIMOTORS dealer, or other qualified person authorized by EGIMOTORS.

OUTSIDE THE COUNTRY WHERE YOUR PRODUCT WAS PURCHASED:

If you are traveling temporarily outside the country where your product was purchased, you should take your product to an authorized EGIMOTORS dealer, or other qualified person authorized by EGIMOTORS. You must show the dealer photo identification from the country of the selling dealer's authorized location as proof of residence. Upon residence verification, the servicing dealer will be authorized to perform the warranty repair.

IF YOU MOVE:

If you move to another country, be sure to contact EGIMOTORS Customer Assistance and the customs department of the destination country before you move. Product importation rules vary considerably from country to country. You may be required to present documentation of your move to EGIMOTORS in order to continue your warranty coverage. You may also be required to obtain documentation from EGIMOTORS to register your product in your new country. We recommend that you register your product at a local authorized EGIMOTORS dealer promptly after you move.

IF YOU PURCHASE FROM A PRIVATE PARTY:

If you purchase a EGIMOTORS product from a private party, to be kept and used outside of the country in which the product was originally purchased, all warranty coverage will be denied. However, we encourage you to promptly register your product at your local authorized EGIMOTORS dealer to receive safety information and notice regarding your product.

EXPORTED PRODUCTS

EXCEPT WHERE SPECIFICALLY REQUIRED BY LAW, THERE IS NO WARRANTY OR SERVICE BULLETIN COVERAGE ON THIS PRODUCT IF IT IS SOLD OUTSIDE THE COUNTRY OF THE SELLING DEALER'S

AUTHORIZED LOCATION. This policy does not apply to products that have received authorization for export from EGIMOTORS. Dealers may not give authorization for export. You should consult an authorized dealer to determine this product's warranty or service coverage if you have any questions. This policy does not apply to products registered to government officials or military personnel on assignment outside the country of the selling dealer's authorized location. This policy does not apply to Safety Bulletins

NOTICE

If tractor is equipped with windshield, remove windshield, or tilt windshield up.
Remove any hardware attached to ROPS right-hand A-pillar.

NOTICE

If your product is registered outside of the country where it was purchased and you have not followed the procedure set above, your product will no longer be eligible for warranty or service bulletin coverage of any kind, other than safety recalls. Products registered to government officials or military personnel on assignment outside of the country where the product was purchased will continue to be covered by the Limited Warranty.

Please work with your dealer to resolve any warranty issues. Dealership contacts can be found via this website, if needed:

www.egimotors.it

Should your dealer require any additional assistance, they will contact the appropriate person at EGIMOTORS.

This warranty gives you specific legal rights, and you may also have other rights which vary from state to state or in different countries. If any of the above terms are void because of federal, state, local law, all other warranty terms will remain in effect.

For questions reach EGIMOTORS on www.egimotors.it

For more information
visit www.Egimotors.it

Egimotors
Via Filippo da Desio 49/51
20832 Desio (MB) ITALY
info@polarisitalia.com